

32.0 MF SERIES FLAKERS MF2006-CMF2306-EMF2306 AIR, WATER & REMOTE

Item Code	Part Description	Part #	MF 2006	CMF 2306	EMF 2306	LP 2306
AIR COOLED						
5	Air Condenser	9141056-01	X	X	X	
10	Fan Blade	9131053-01	X	X	X	
15	Fan Bracket	9131060-01	X	X	X	
20	Fan Motor	9161078-03	X	X	X	
25	Fan Shroud	9131134-01	X	X	X	
30	Fan Shroud - Push Rivet	9031009-01	X	X	X	
35	Fan Cycle Pressure Control	9041003-02	X	X	X	
AUGER MOTOR KITS						
100	Auger Motor 1/2" Shaft (Replaced By Kit)*	2061493-01	X			
100	Auger Motor 1/2" Shaft (Replaced By Kit)**	1051068-09	X	X		
*To Replace G.E. Motors Only (Includes Emerson Motor, Pulleys, Keys and Motor Mounting Bracket)						
**To Replace Emerson Motors (Includes Motor, Pulleys And Keys)						
AUGER MOTOR						
105	Auger Motor Key 5/8" Shaft	9021028-01	X	X	X	X
110	Auger Motor 5/8" Shaft	9161097-01	X	X	X	X
110	Auger Motor 1/2" Shaft	USE KIT	X			
COUPLER						
115	Coupler Assy (Keyed) (3/4 x 3/4)	2081012-05			X	X
120	Coupler-Lower Half (Gear Reducer)	9111004-92	X	X	X	X
125	Coupler-Upper Half (Double "D" Auger)	9111004-90	X			
125	Coupler-Upper Half (Keyed Auger)	9111004-92		X	X	X
130	Coupler-Spyder Gear (Plastic)	9111004-91	X	X	X	X
135	Set Screw-Coupler	9031033-09	X	X	X	X
COMPRESSOR AND COMPONENTS (*Kit Includes Drier and Start Components)						
200	*Compressor Kit	9181068-11	X	X		
200	*Compressor Kit	9181090-11			X	
210	Run Capacitor	9181009-12	X	X	X	
215	Start Capacitor	9181003-19	X	X	X	
220	Start Relay	9181010-10	X	X	X	
DOWN CHUTE-STAINLESS STEEL SQUARE FOAMED						
405	Down Chute Assy	NLA	X			
410	Down Chute Only (Less Components)	NLA	X			
415	Damper Door Assembly	NLA	X			
420	Down Chute Cover	NLA	X			
425	Mounting Plate	NLA	X			
430	Mounting Plate Insulator	NLA	X			
435	Switch Insulator	3051130-01	X			
440	Switch	9101114-01	X			
445	Switch Actuator	9101114-02	X			
DOWN CHUTE-WHITE PLASTIC ROUND						
400	Bin Control Tube	3032258-02		X		
407	Down Chute Switch Actuator	9051283-01		X		
420	Push-on Nut (Retains Bin Control Tube)	9031133-01		X		
425	Screw Machine #6-32 x 7/8 (Switch)	9031008-29		X		
430	Speed Nut (Switch)	9031011-01		X		
435	Switch Bracket	3012382-01		X		
440	Switch Insulator	3051130-01		X		
445	Switch - Modified	3051163-01		X		
455	Chute Brace	3012381-01		X		
460	Chute Cover - Slanted	9051328-01		X		
462	Down Chute Assy - Slanted Top	2101205-04		X		
465	Screw #4 - 24 x 3/8	9031113-01		X		

32.0 MF SERIES FLAKERS MF2006-CMF2306-EMF2306 AIR, WATER & REMOTE

Item Code	Part Description	Part #	MF 2006	CMF 2306	EMF 2306	LP 2306
DOWN CHUTE-GREY PLASTIC ROTO-MOLDED						
400	Bin Control Tube	3032258-02		X	X	X
405	Down Chute Assembly	2101236-03		X	X	X
405	Down Chute Switch Actuator	9051381-01		X	X	X
410	Down Chute (Less Components)	9051369-03		X	X	X
412	Down Chute Mounting Bracket	3012683-01		X	X	X
415	Down Chute Strap	3012535-03		X	X	X
420	Push-on Nut (Retains Bin Control Tube)	9031133-01		X	X	X
425	Screw Machine #6-32 x 7/8 (Switch)	9031008-29		X	X	X
430	Speed Nut (Switch)	9031011-01		X	X	X
435	Switch Bracket	3012382-01		X	X	X
440	Switch Insulator	3051130-01		X	X	X
445	Switch - Modified	3051163-01		X	X	X
450	Tab Cap	9101115-01		X	X	X
ELECTRICAL						
230	Low Temp Safety Control (Thermostat)	9041002-01	X	X	X	X
235	Bin Thermostat	9041004-02	X	X	X	X
240	Switch Toggle - On/Off	9101001-02	X	X	X	X
245	Contactor	9101002-04	X	X	X	X
250	Terminal Board - 3 Position A & W	9101037-01	X	X	X	X
250	Terminal Board - 4 Position R	9101037-02	X	X	X	X
260	Timing Module	9101140-02	X	X	X	X
265	Relay - Auger Motor	9101170-02	X	X	X	X
270	Dual Terminal Adapter	9101041-01	X	X	X	X
275	Relay Socket	9101083-01	X	X	X	X
280	Relay	9101084-02	X	X	X	X
EVAPORATOR REPLACEMENT KITS						
325	Service Kit-Evap Assy Replacement Left/Right*	1051050-01	X			
326	Service Kit-Evap Barrel Replacement Left/Right**	1051051-01	X			
*(Includes TXV, Tubing, & Wrapped Evap With Auger/Housing Assy)						
**(Includes TXV, Tubing, & Wrapped Evap Without Auger/Housing Assy)						
EVAPORATOR						
	Bearings, Water Seal, Nut and O-Ring	1051111-01	X			
300	Auger Kit (Keyed)	1051071-01	X			
300	Auger (Keyed)	9131283-01		X	X	X
305	Bearing & Housing Assembly - Lower	2051029-01	X	X	X	X
310	Bearing & Housing Assembly - Upper	2051159-01	X	X	X	X
315	Bearing - Lower 9121001-01	9121001-05	X	X	X	X
320	Bearing-Upper (Tapered)	9121039-01		X	X	X
321	Bearing Kit W/Spacer - Upper 9121001-01	1051039-01	X			
322	Spacer for Upper Bearing	9031117-01	X			
325	Evaporator Assy (LH & RH Discharge)	USE KITS	X			
326	Evaporator Barrel (LH & RH Discharge)	USE KITS	X			
327	Evaporator Assy (RH Discharge) (W/O TXV)**	2051185-91S		X	X	X
328	Evaporator Assy (LH Discharge) (W/O TXV)*	2051186-91S		X	X	X
329	Evaporator Barrel (RH Discharge) (W/O TXV)**	2051167-91		X	X	X
330	Evaporator Barrel (LH Discharge) (W/O TXV)*	2051163-91		X	X	X
335	Evaporator Cap	3011012-01	X	X	X	X
340	Gasket-Evap. To Ice Chute 9051012-01	SEE BELOW				
As per Service Bulletin #14-97 the following 3 parts are required for the new type gasket						
340	Primary Ice Chute Gasket	3051198-01		X	X	X
340	Secondary Gasket	3991045-01		X	X	X
340	Retaining Strap	3012729-03		X	X	X
345	Hex Bolt	9031001-01	X	X	X	X
350	Housing - Lower Bearing	9131218-01	X	X	X	X
355	Housing - Upper Bearing	9131217-01	X	X	X	X
360	Locating Pin (Upper Housing)	9131010-02	X	X	X	X
365	O-Ring - Lower	9131009-01	X	X	X	X
370	O-Ring - Upper	9131009-02	X	X	X	X

32.0 MF SERIES FLAKERS MF2006-CMF2306-EMF2306 AIR, WATER & REMOTE

Item Code	Part Description	Part #	MF 2006	CMF 2306	EMF 2306	LP 2306
EVAPORATOR (Continued)						
375	Retaining Nut - Upper or Lower	9131206-01	X	X	X	X
380	Set Screw - Evaporator Nut (Lower)	9031033-03	X	X	X	X
380	Set Screw - Evaporator Nut (Lower)	9031033-03	X	X	X	X
385	Washer	9031004-09	X	X	X	X
390	Water Seal & Face Assembly	9121025-91	X	X	X	X
	(*COMMON TO CMF1106-WRAPPED EVAP)					
	(**COMMON TO CMF2306 ONLY-WRAPPED EVAP)					
GEAR REDUCER ED 18						
140	Baldor Gear Reducer	9171010-03	X	X	X	X
	Internal Parts for BALDOR Gearbox are not available.					
	Internal Parts for the MORRIS Gear Reducers are No Longer Available					
ICE CHUTE						
480	Ice Chute Assy (RH-White Down Chute)	2021448-02		X		
480	Ice Chute Assy (LH-White Down Chute)	2021448-03		X		
480	Ice Chute Assy	NLA	X			
MISCELLANEOUS						
485	Gasket - Ice Chute To Down Chute	9051240-01		X		
490	Drip Boot	9051006-01	X	X	X	X
492	Evaporator Sweat Cap (Square Down Chute)	2991005-01	X			
492	Evaporator Sweat Cap (White Down Chute)	9131255-01		X		
492	Evaporator Sweat Cap (Grey Down Chute)	9131328-01		X	X	X
493	Ice Deflector	3011865-01	X	X	X	X
495	Y-Drain	9091083-01	X			
PANELS						
	Paint Beige Touch-up (Spray Can)	NLA	X			
	Paint Grey Touch-up (Spray Can)	5011077-20		X	X	
502	Control Box Cover	NLA	X	X	X	X
506	Front Panel Assy, Grey	NLA	X	X	X	X
506	Front Panel Assy, Stainless	2031378-01	X	X	X	X
514	Cabinet Brace-Rear	3021416-01	X	X	X	X
515	Cabinet Brace-Front	3021585-01	X	X	X	X
516	Back Panel	3021417-01	X	X	X	X
518	Screw #8 - 18 x 1-1/2	9031046-14	X	X	X	X
518	Screw #8 - 18 x 1-1/2, Stainless	9031046-18	X	X	X	X
524	Screw #8-1/2 (Side Panel & Top)	9031074-01	X	X	X	X
528	Side Panel LH, Grey	NLA	X	X		
528	Side Panel LH, Stainless	3021562-02	X	X		
528	Side Panel LH, Grey	NLA			X	X
528	Side Panel LH, Stainless	3021562-02			X	X
530	Side Panel RH, Grey	NLA	X	X		
530	Side Panel RH, Stainless	3021394-02	X	X		
530	Side Panel RH, Grey	NLA			X	X
530	Side Panel RH, Stainless	3021559-02			X	X
536	Top Panel, Grey	NLA	X	X	X	X
536	Top Panel, Stainless	3021393-02	X	X	X	X
537	Mounting Base-Auger Motor	3012291-01	X	X	X	X
539	Mounting Panel-Evaporator	3021586-01	X	X	X	X
PULLEYS						
185	Gear Reducer Pulley	9111002-15	X	X	X	X
190	Pulley - Auger Motor 5/8" Bore	9111002-30		X	X	X
190	Pulley - Auger Motor 1/2" Bore	NLA		X		
REFRIGERATION						
600	Drier	9151004-04	X	X	X	X
602	Expansion Valve - Automatic	9151056-01	X			
605	Expansion Valve - Thermostatic (Flared)	9151006-01	X			
605	Expansion Valve - Thermostatic (Sweat)	9151006-06		X		
605	Expansion Valve	9151006-08			X	X

32.0 MF SERIES FLAKERS MF2006-CMF2306-EMF2306 AIR, WATER & REMOTE

Item Code	Part Description	Part #	MF 2006	CMF 2306	EMF 2306	LP 2306
REFRIGERATION (Continued)						
605	Expansion Valve Adjustable (Beg. Serial J3)	9151134-09			X	
	Evaporator Pressure Reg. Valve	9151096-01				X
610	High Pressure Control (400 PSI)	9041001-02	X	X		
610	High Pressure Control (450 PSI)	9041001-04			X	
615	Service Valve Assy	2101160-01	X	X	X	X
615	Service Valve Cap	9091086-03	X	X	X	X
625	Service Valve Core	9091086-02	X	X	X	X
REMOTE						
700	Mixing Valve (Head Pressure)	9151027-06	X	X	X	
710	Liquid Line Solenoid Body - ALCO	9151123-02	X	X	X	X
710	Liquid Line Solenoid Coil - ALCO 230V	9151123-04	X	X	X	
720	Pump Down Pressure Control	9041040-01	X	X	X	X
725	Receiver	9151060-01	X	X	X	
REMOTE CONDENSER						
740	Coupling Half (Bulkhead 1/2)	9091001-12	X	X	X	
745	Coupling Half (Bulkhead 3/8)	9091001-11	X	X	X	
750	Coupling Half Lineset (1/2)	9091001-08	X	X	X	
755	Coupling Half Lineset (1/2 W/ Service Port)	9091001-10	X	X	X	
760	Coupling Half Lineset (3/8)	9091001-02	X	X	X	
765	Coupling Half Lineset (3/8 W/ Service Port)	9091001-04	X	X	X	
766	Coupling Half Mounting Flange (1/2)	9091001-09	X	X	X	
767	Coupling Half Mounting Flange (3/8)	9091001-03	X	X	X	
770	Fan Motor (I-O-M Only)	9161110-02	X	X	X	
775	Fan Shroud (I-O-M Only)	9131356-01	X	X	X	
780	Fan Blade (I-O-M Only)	9131357-01	X	X	X	
770	Fan Motor (LARKIN ONLY)	1011179-99	X	X	X	
775	Fan Shroud (LARKIN ONLY)	1011179-97	X	X	X	
780	Fan Blade (LARKIN ONLY)	1011179-98	X	X	X	
V-BELT						
195	V-Belt #2310	9111001-01	X	X	X	X
WATER COOLED						
800	Water Valve Regulator	9041010-01	X	X	X	
805	Water Condenser	9141057-01	X	X	X	
WATER FLOAT						
810	Water Inlet Tube (4.17 FT. PLASTIC TUBE)	6021032-01			X	X
815	Water Float & Tank Assembly	9131032-01	X	X	X	X
820	Water Valve And Float Only	9131111-01	X	X	X	X
825	Float Mounting Bracket	3011828-01	X	X	X	X
WATER PURGE SYSTEM						
830	Purge Valve (230V)	9041083-02			X	X
835	Timer	9101148-01			X	X
840	Relay (230V)	9101084-02			X	X
845	Relay Socket	9101083-01			X	X

REFRIGERANT CHARGE		
MODEL	REF TYPE	OZ.
MF2006-CMF2306 AIR	R502	98
MF2006-CMF2306W	R502	37
MF2006-CMF2306 REMOTE	R502	220
EMF2306 AIR	R404A	84
EMF2306 WATER	R404A	36
EMF2306 REMOTE	R404A	240

PRESSURES		
SP	DP	HP
39		
39	225	400
39		400
45		
45	250	450
45		450

SP=SUCTION PRESSURE

DP=DISCHARGE PRESSURE SETTING/WATER COOLED UNITS

HP= HIGH PRESSURE SAFETY CONTROL SETTING

32.1 50HZ MF SERIES FLAKERS MF2005-CMF2005-EMF2305 AIR, WATER & REMOTE

Item	MF	CMF	EMF
------	----	-----	-----

Code	Part Description	Part Number	GRP	2005	2005	2305
AIR COOLED						
5	Air Condenser	9141056-01	AC	X	X	
5	Air Condenser	9141098-01	AC			X
20	Fan Motor	9161078-03	AC	X	X	X
AUGER MOTOR KITS						
100	Auger Motor 1/2" Shaft (Replaced By Kit)*	2061493-01	AMK	X		
100	Auger Motor 1/2" Shaft (Replaced By Kit)**	1051068-09	AMK	X	X	
*To Replace G.E. Motors Only (Includes Emerson Motor, Pulleys, Keys and Motor Mounting Bracket)						
**To Replace Emerson Motors (Includes Motor, Pulleys And Keys)						
AUGER MOTOR						
105	Auger Motor Key 5/8" Shaft	9021028-01	AM	X	X	X
110	Auger Motor 5/8" Shaft	9161097-01	AM	X	X	X
110	Auger Motor 1/2" Shaft	USE KIT	AM	X		
COMPRESSOR AND COMPONENTS (*Kit Includes Drier and Start Components)						
200	*Compressor Kit	9181068-11	C	X	X	
200	*Compressor Kit	9181102-01	C			X
210	Run Capacitor	9181009-12	C	X	X	
210	Run Capacitor	9181009-04	C			X
215	Start Capacitor	9181003-19	C	X	X	
215	Start Capacitor	9181003-31	C			X
220	Start Relay	9181010-10	C	X	X	
220	Start Relay	9181010-20	C			X
DOWN CHUTE-STAINLESS STEEL SQUARE FOAMED						
440	Switch	9101114-01	DCS	X		
DOWN CHUTE-WHITE PLASTIC ROUND						
445	Switch - Modified	3051163-01	DCP		X	
DOWN CHUTE-GREY PLASTIC ROTO-MOLDED						
445	Switch - Modified	3051163-01	DCR		X	X
ELECTRICAL						
245	Contactor	9101002-04	E	X	X	X
260	Timing Module	9101140-02	E	X	X	X
265	Relay - Auger Motor	9101170-02	E	X	X	X
280	Relay	9101084-02	E	X	X	X

REFRIGERANT CHARGE			PRESSURES			
MODEL	REF TYPE	OZ.	SP	DP	HP	
MF2005-CMF2005 AIR	R502	98	39			
MF2005-CMF2005W	R502	37	39	225	400	
MF2005-CMF2005 REMOTE	R502	220	39		400	

SP=SUCTION PRESSURE

DP=DISCHARGE PRESSURE SETTING/WATER COOLED UNITS

HP= HIGH PRESSURE SAFETY CONTROL SETTING

MF2000, CMF-EMF2300 SERIES FLAKER

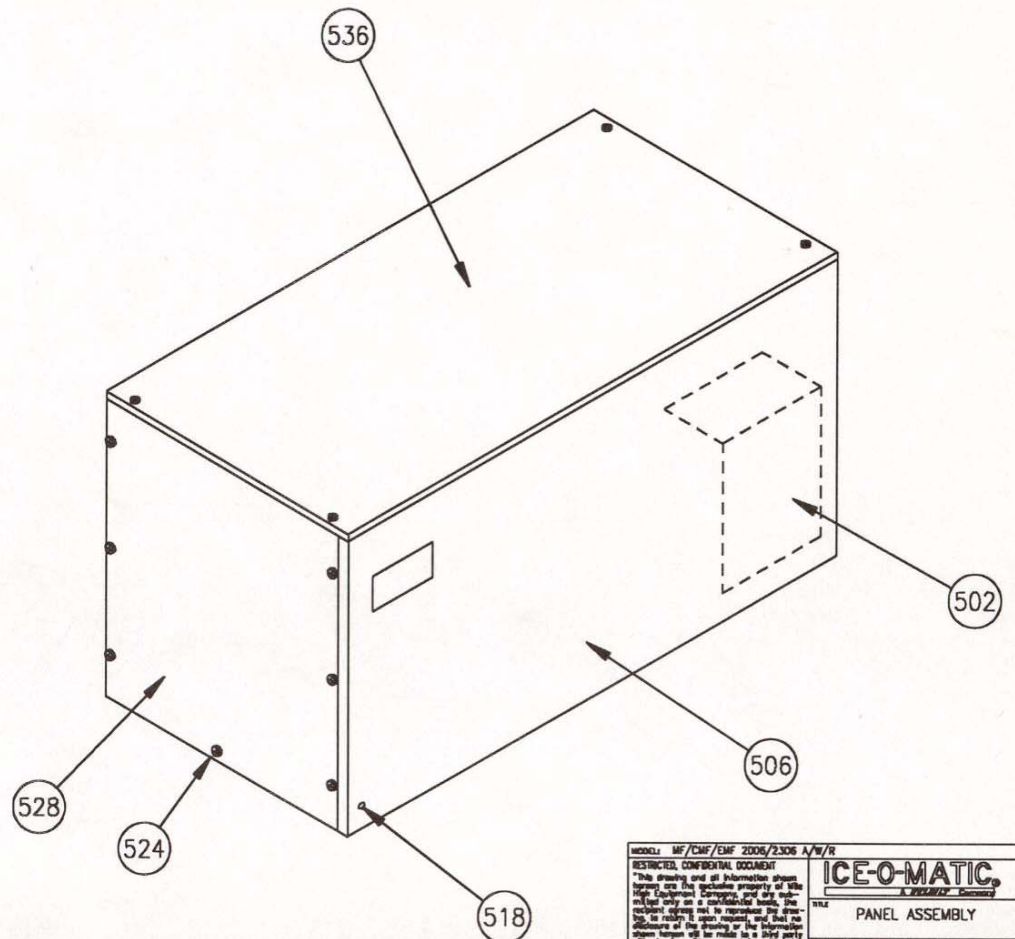
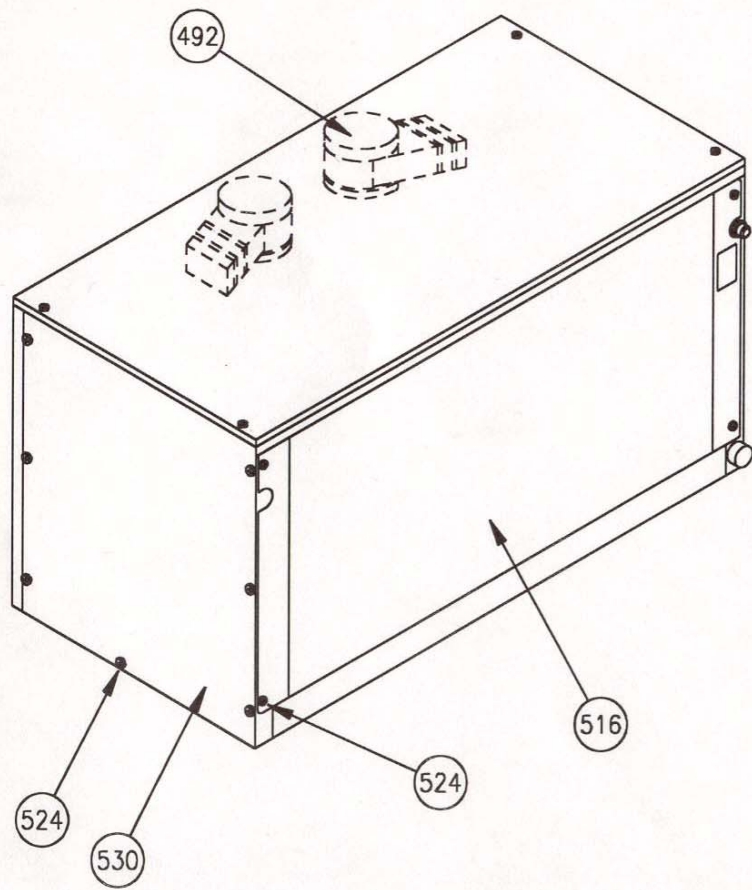

MODEL: MF/CMF/EMF 2006/2306 A/W/R
 RESTRICTED, CONFIDENTIAL DOCUMENT
 *This drawing and all information shown hereon are the exclusive property of the High Equipment Company and are not to be used, copied, or reproduced in any form without the written consent of the High Equipment Company.
ICE-O-MATIC
 A WILCOX COMPANY
 TITLE: PANEL ASSEMBLY
 SCALE: 1/8" = 1'-0" DATE: MF2000-1

MF2000, CMF-EMF2300 SERIES FLAKER

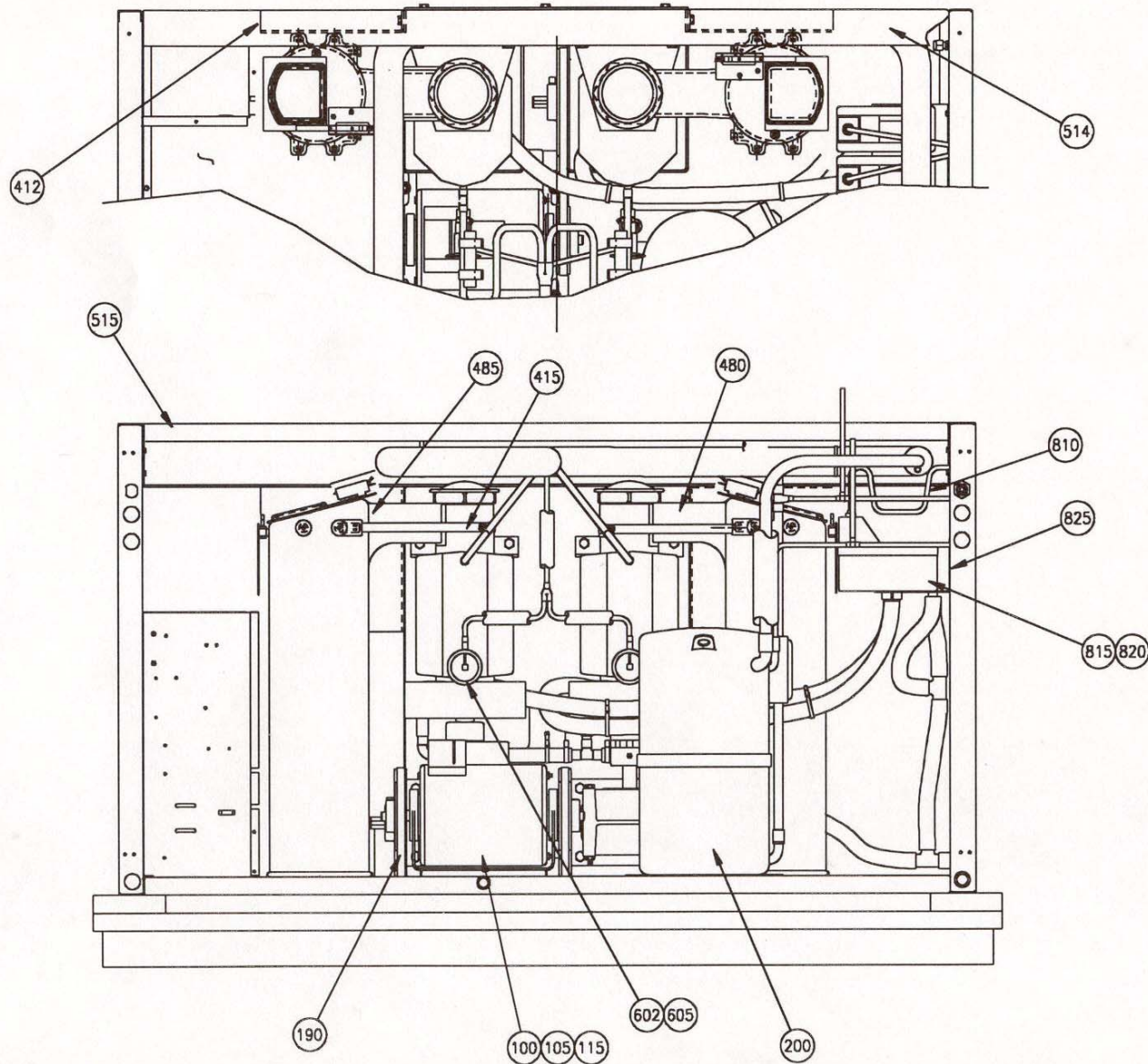

MODEL: MF/CMF/EMF 2000/2300 A/W/R RESTRICTED, CONFIDENTIAL DOCUMENT "This drawing and all information shown hereon are the exclusive property of the High Equipment Company, and are not to be used, copied, or reproduced in any manner, in whole or in part, without the written consent of the High Equipment Company."			
ICE-O-MATIC <small>A FORTY-FIVE COMPANY</small>			TITLE CHASSIS ASSEMBLY
SCALE 1=1	SHEET 1 OF 1	DATE 1/78	PART NO. MF2000-2

MF2000, CMF-EMF2300 SERIES FLAKER

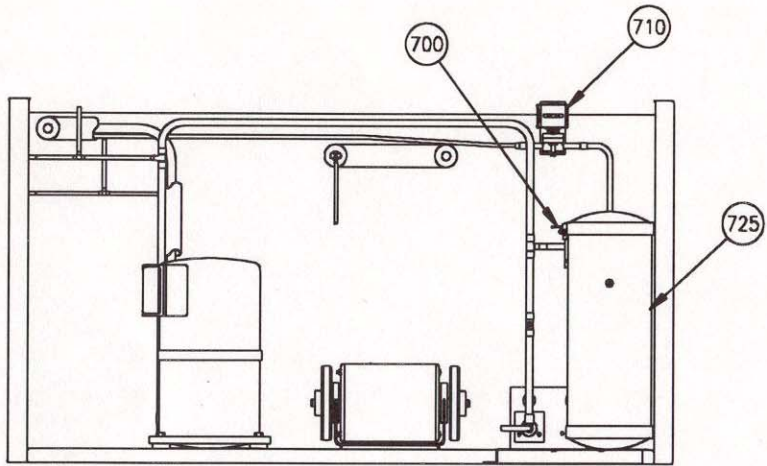

REMOTE UNITS

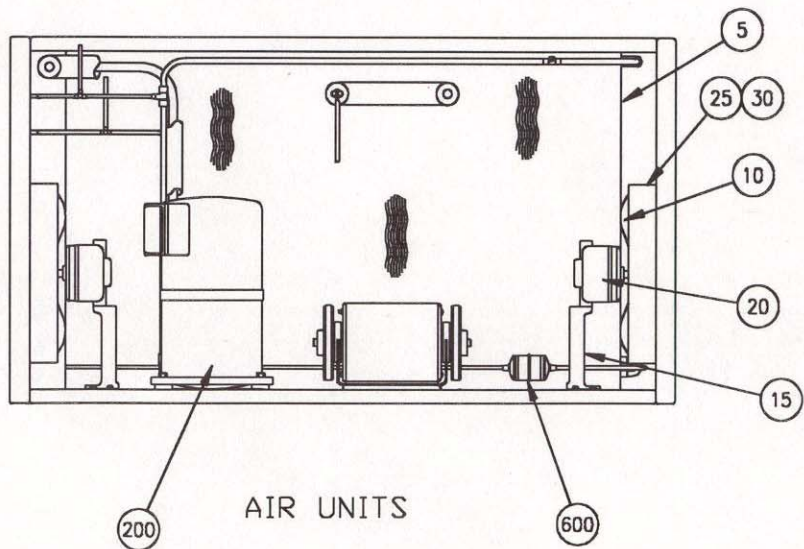
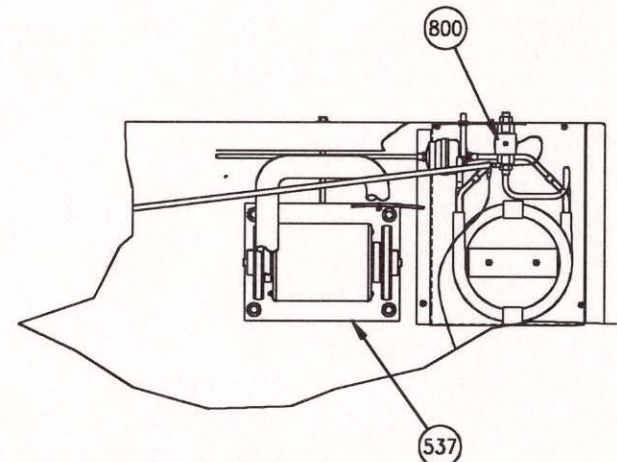

AIR UNITS

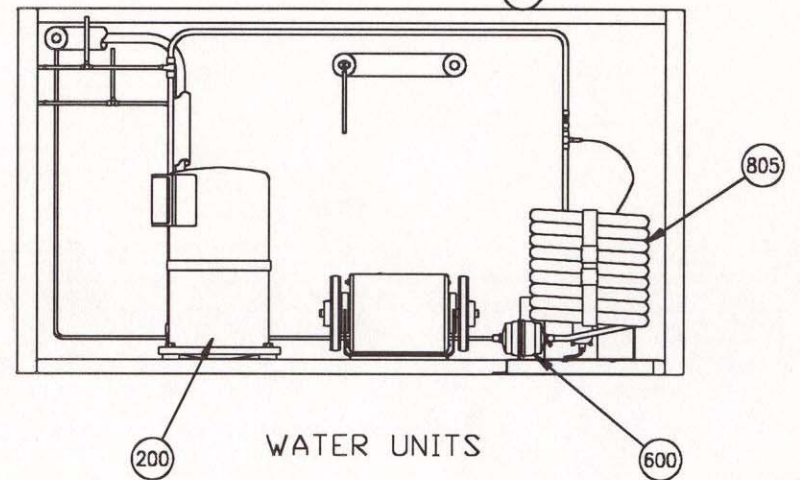

WATER UNITS

MF2000, CMF-EMF2300 SERIES FLAKER

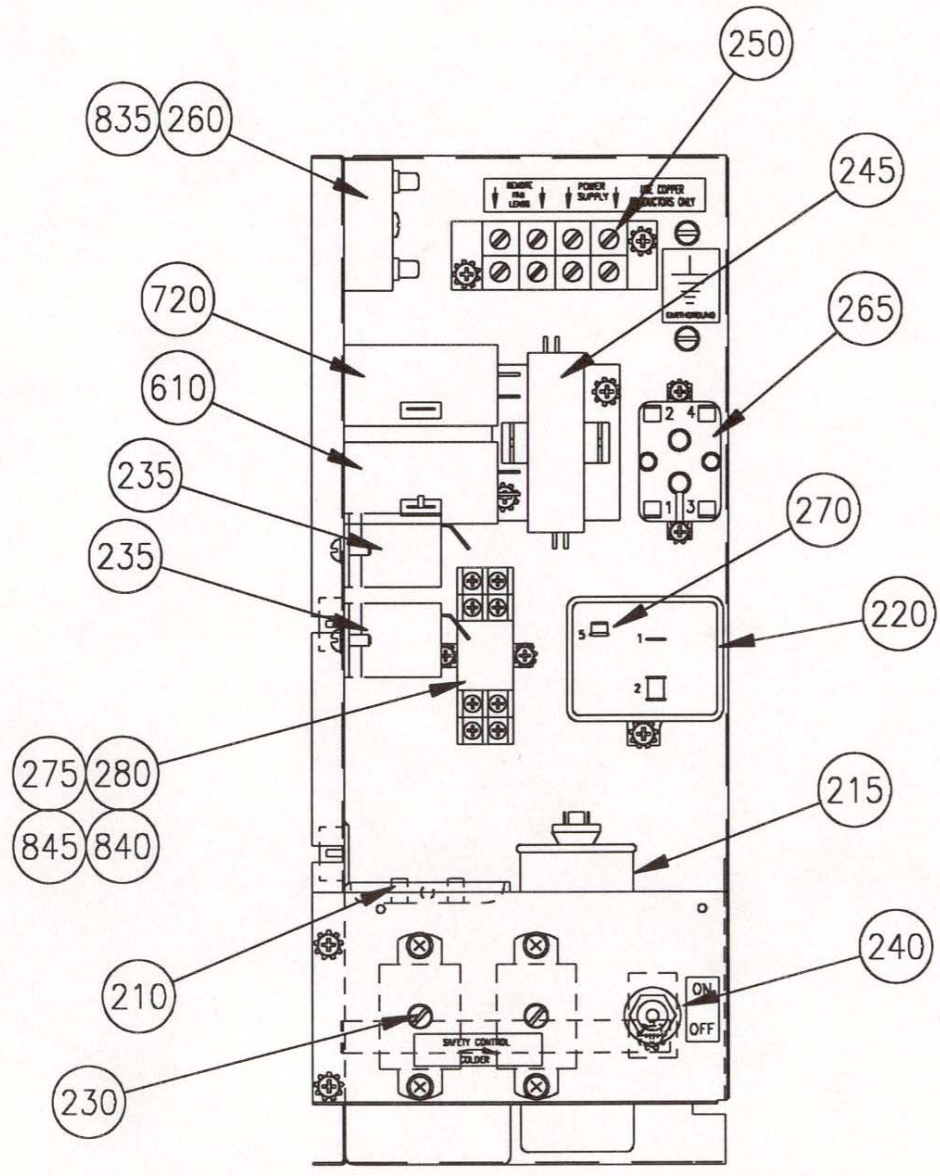

MODEL: MF/CMF/EMF 2000/2300 A/N/R
 RESTRICTED, CONFIDENTIAL DOCUMENT
 This drawing and all information contained herein are the exclusive property of the High Equipment Company, and any reproduction, in whole or in part, without the written consent of the High Equipment Company is prohibited. The recipient agrees not to reproduce the drawing, to make it available, and not to disclose the drawing or the information shown herein to a third party without prior written consent from the High Equipment Company.
ICE-O-MATIC
 A WEAVER COMPANY
 CONTROL BOX ASSEMBLY
 SHEET THREE

MF2000, CMF-EMF2300 SERIES FLAKER

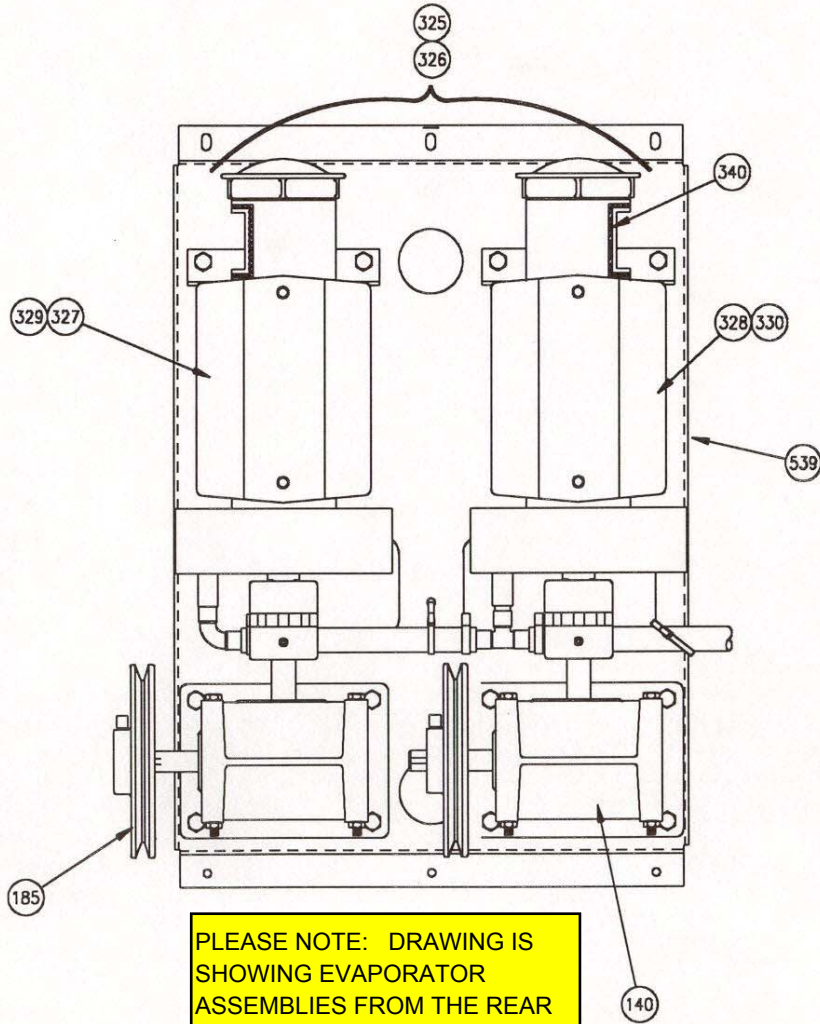

PLEASE NOTE: DRAWING IS SHOWING EVAPORATOR ASSEMBLIES FROM THE REAR OF THE UNIT.

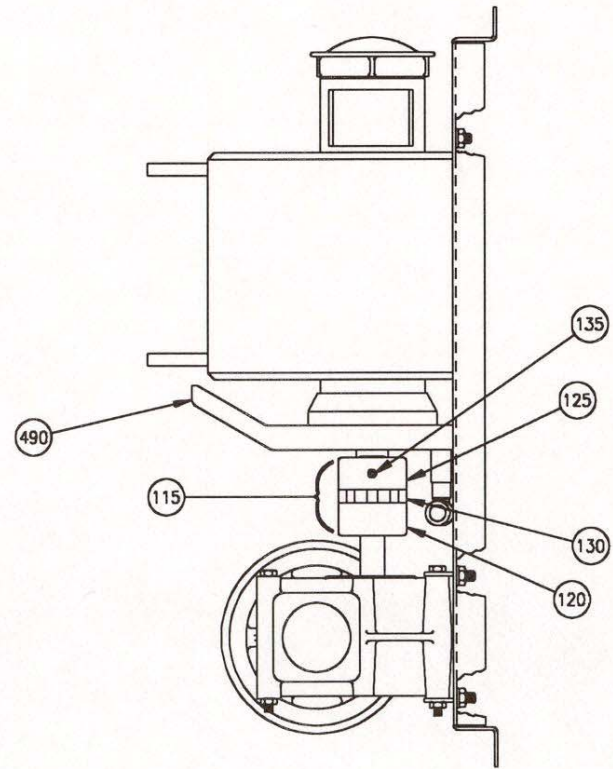

<p>MODEL: MF/CMF/EMF 2000/2300 A/R/R</p> <p>RESTRICTED, CONFIDENTIAL DOCUMENT</p> <p><small>This drawing and all information shown herein are the exclusive property of the High Equipment Company, and are not to be used, in whole or in part, without the written consent of the High Equipment Company. The recipient agrees not to reproduce the drawing, in whole or in part, and that no disclosure of the drawing or the information shown herein will be made to a third party without the written consent of the High Equipment Company.</small></p>	<p>ICE-O-MATIC A FINEKOP Company</p> <p>TITLE: EVAPORATOR MOUNTING PANEL ASSEMBLY</p>
--	--

MF2000, CMF-EMF2300 SERIES FLAKER

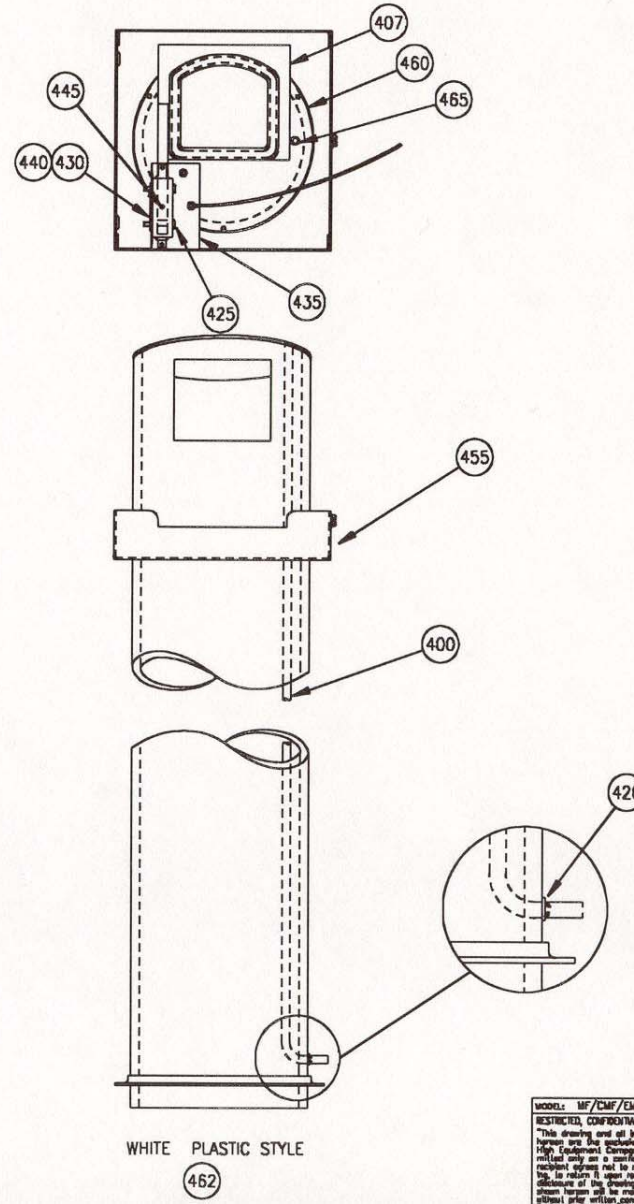
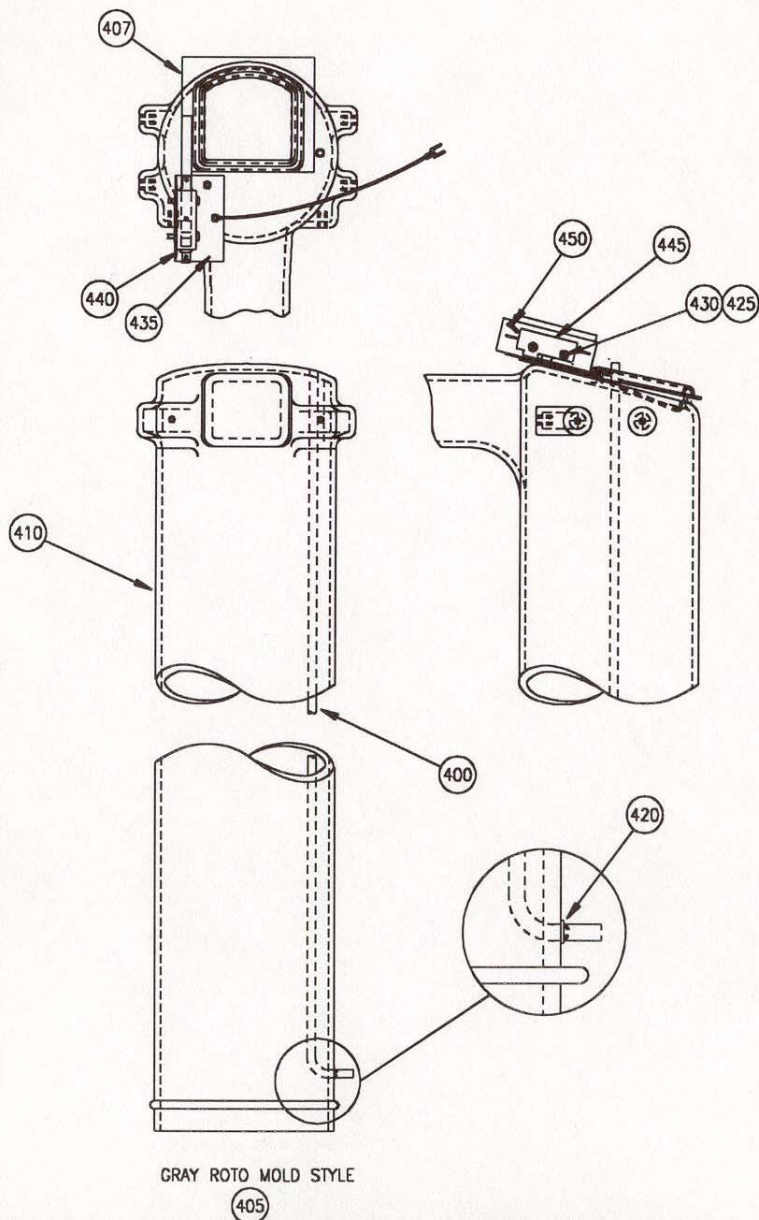

MODEL: MF/CMF/EMF - A/W/R

RESTRICTED, CONFIDENTIAL DOCUMENT
 This drawing and all information herein are the exclusive property of the High Equipment Company, and are furnished only as a confidential loan. The recipient agrees not to reproduce the drawing, to return it upon request, and that no disclosure of the drawing or the information herein will be made to a third party without prior written consent from the High Equipment Company.

ICE-O-MATIC
 A PERFORMER COMPANY

DATE: _____
 TITLE: DOWN CHUTE ASSEMBLY

SCALE: 1" = 1" SHEET: 13821

MF2000, CMF-EMF2300 SERIES FLAKER

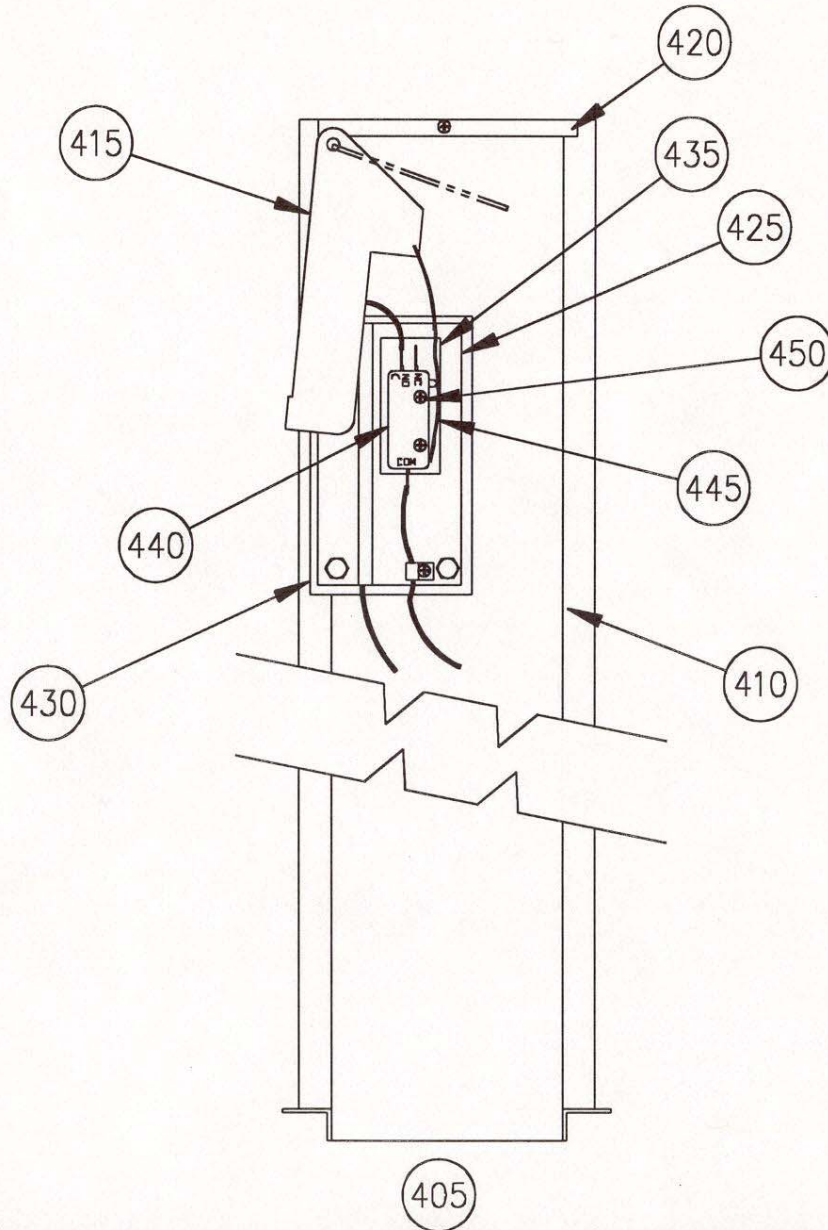

<small>RESTRICTED, CONFIDENTIAL DOCUMENT</small> <small>*This drawing and all information shown herein are the exclusive property of the High Equipment Company, and are submitted only on a confidential basis. The recipient agrees not to reproduce the drawing, to return it upon request, and that no disclosure of the drawing or the information shown herein will be made in a direct or indirect way without approval from the High Equipment Company.</small>		ICE-O-MATIC, <small>A BIRDAIR® Company</small>	
<small>FILE</small> (STEEL) DOWN CHUTE ASSEMBLY		<small>SCALE</small> 1:1 <small>DATE</small> 1/25/88 <small>BY</small> JLB <small>STITCHED</small>	

MF2000, CMF-EMF2300 SERIES FLAKER

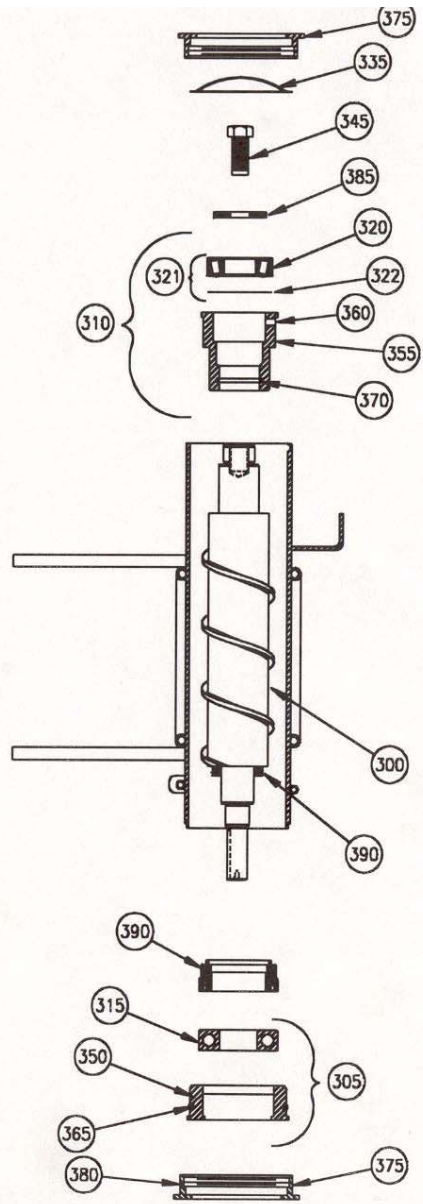

<p>RESTRICTED, CONFIDENTIAL DOCUMENT <small>*This drawing and all information herein are the exclusive property of IBC. All rights reserved. This drawing is not to be reproduced, stored in a retrieval system, or transmitted in any form or by any means, electronic, mechanical, photocopying, recording, or by any information storage and retrieval system, without prior written consent from IBC.</small></p>		<p>ICE-O-MATIC <small>A WATSON-COOK COMPANY</small></p>	
<p>MODEL: MF2000, CMF-EMF2300</p>		<p>TITLE: EVAPORATOR ASSEMBLY</p>	
<p>DATE: _____</p>		<p>SCALE: 1:1 (SEE TABLE)</p>	

MF2000, CMF-EMF2300 SERIES FLAKER

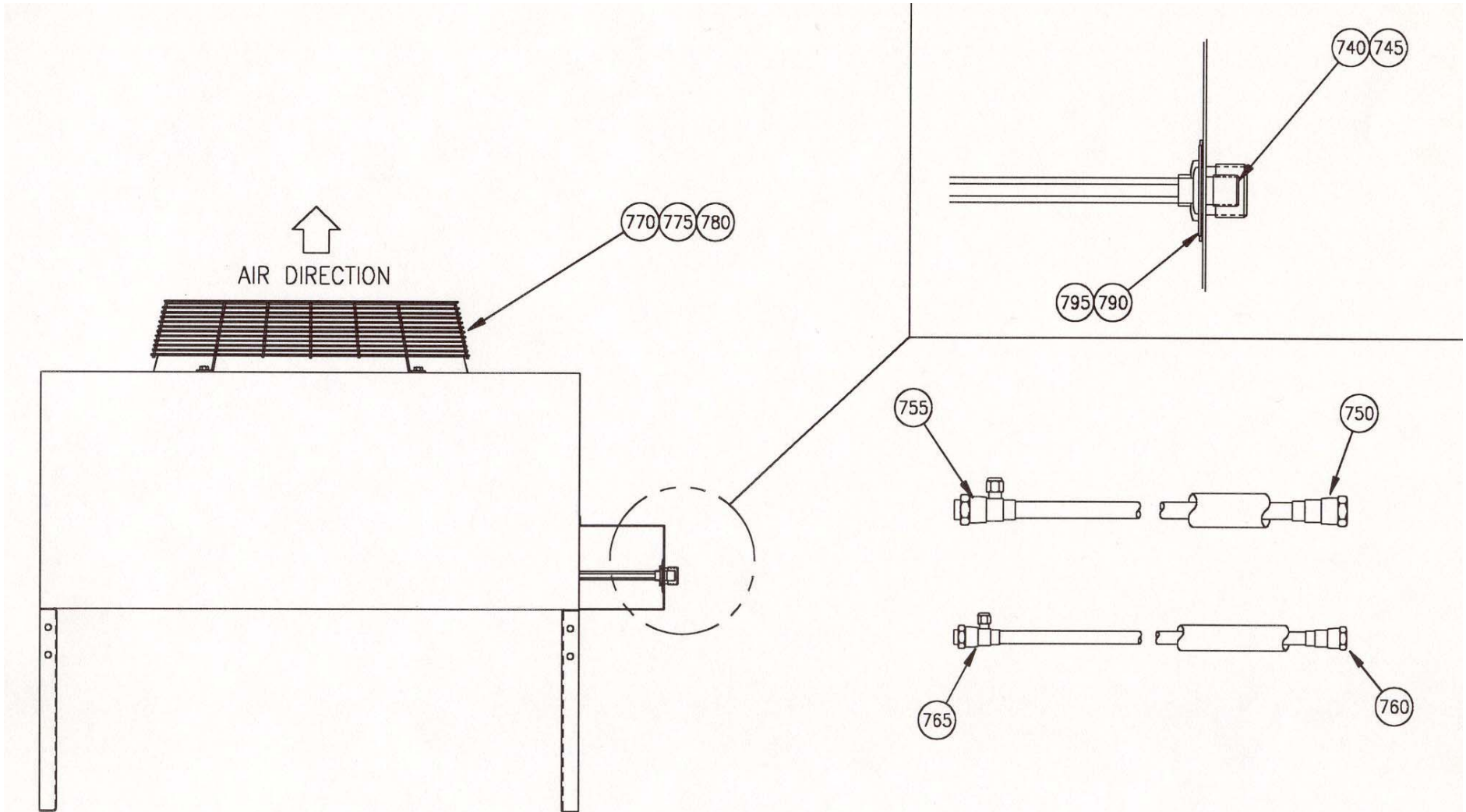

MODEL: "B" SERIES AIR/WATER/REMOTE
 RESTRICTED, CONFIDENTIAL DOCUMENT
 This drawing and all information herein are the exclusive property of the
 Equipment Company, and are not
 to be used in any way on a confidential basis. The
 recipient agrees not to reproduce the drawing,
 in whole or in part, without the written
 consent of the drawing or the information
 company.

ICE-O-MATIC.
 A PERKINS COMPANY

FILE
 REMOTE CONDENSOR