

Ice-O-Matic[®]

SERVICE AND INSTALLATION MANUAL EF and EMF Series Flaked ICE Machines



ICE-O-Matic
11100 East 45th Ave
Denver, Colorado 80239
Part Number 9081325-01

Print Date 1/07

Flake Ice Machines

Table Of Contents

General Information

Model and Serial Number Format	A3-A4
Electrical and Mechanical Specifications	A5
Installation Guidelines	A6
Electrical and Plumbing Requirements	A7-A9
Remote Condenser Installation	A10
Warranty Information	A11
General Operation	A12

Scheduled Maintenance

Maintenance Procedure	B1
Cleaning and Sanitizing Instructions	B2
Winterizing Procedure	B3
Cleaning Stainless Steel	B4

Troubleshooting Trees

Introduction	C1
Machine Runs, Does Not Make Ice	C2
Machine Does Not Run	C4
Slow Production	C5
Low Suction Pressure	C6
High Suction Pressure	C7
Machine Freezes Up (Auger Seizes)	C8
Auger Motor Amperage Fluctuations	C9
Water Leaking From Evaporator	C10
Machine Produces Wet Ice	C11
Hot Evaporator, Low Suction Pressure	C12
Noise Coming From Evaporator	C13

Water System

Float Valve and Reservoir	D1
Water Seal and O-Rings	D2
Drip Boot	D2

Drive System

Auger Drive Motor and V-Belt	E1
Gear Reducer	E2
Coupler	E2
Evaporator and Internal Components	E3
Evaporator Disassembly	E3
Evaporator and Auger Inspection	E5
Bearing, Water Seal and O-Rings	E6
Seal Face Installation	E7
Evaporator Reassembly	E7

Refrigeration System

Refrigeration System and Components	F1
Compressor	F1
Refrigerant Pressures	F2
Air Cooled Condenser	F5
Water Cooled Condenser	F6
Water Regulating Valve	F6
High Pressure Safety Control	F6
Expansion Valve	F7
Production Check	F8
Evaporator	F9
Remote System	F10

Refrigeration System (Continued)

Mixing Valve	F10
Pump Down System	F11
Liquid Line Solenoid	F11
Receiver	F12
Refrigerant	F13

Electrical System

Control Circuit	G1
Compressor and Start Components	G1
Safety Control	G3
Bin Control	G3
Auger Motor Relay	G4
Auger Motor	G4
Compressor Delay	G5
Pump Down System	G5
Pump Down Control	G5

Wiring Diagrams

EF240/255/405, EF450 A/W	G6
EF800 A/W	G7
EMF450/405 A/W	G8
EMF800 A/W	G9
EMF705/1005/1006 A/W	G10
EMF1106 R	G11
EMF2306 A/W	G12
EMF2306 R	G13
EMF2305L	G14

ICE-O-Matic provides this manual as an aid to the service technician for installation, operation, and maintenance of flaked ice machines. This manual covers all EF and EMF series flaked ice machines. If used properly, this manual can also help the service technician troubleshoot and diagnose most of the problems that may occur with the machine.

Sections A and B of this manual provide general and maintenance information. The remainder of the manual, beginning with Section C, provides troubleshooting information. Section C contains flow charts called troubleshooting trees. Page C1 provides instructions on using the troubleshooting trees. Each troubleshooting tree is named to describe a particular problem with the operation of the machine.

When following the troubleshooting trees, the service technician will be led through questions and checks and end up at a probable solution. When using the troubleshooting trees it is important that the service technician understand the operation and adjustments of the components being checked and the component suspected of being defective. A detailed description of the operation and adjustments of the components as well as other service information is laid out in the pages that follow Section C.

Each section, after Section C, focuses on a particular system in the ice machine; water system, drive system, refrigeration system and electrical system. It is important that these sections be used together with the troubleshooting trees in Section C.

Most aspects of flake ice machines are covered in this manual. However, should you encounter any conditions not addressed herein, please contact the ICE-O-Matic Technical Service Department for assistance at the numbers listed below, or write the ICE-O-Matic Service Department.

ICE-O-Matic
11100 East 45th Ave.
Denver CO 80239
Attn: Technical Service Department

Phone: (800) 423-3367 After Hours Only (888) FIX-4-ICE (349-4423)
Fax: (303) 576-2944
E-Mail Tech.service@iceomatic.com

Any service communication must include:

- Model Number
- Serial Number
- A detailed explanation of the problem

WARNING: Always disconnect electrical power and shut off water supply whenever maintenance or repairs are performed on the ice machine and related equipment.

CAUTION: Always wear protective eyewear whenever maintenance or repairs are performed on the ice machine and related equipment.

Model and Serial Number Format

Model Numbers

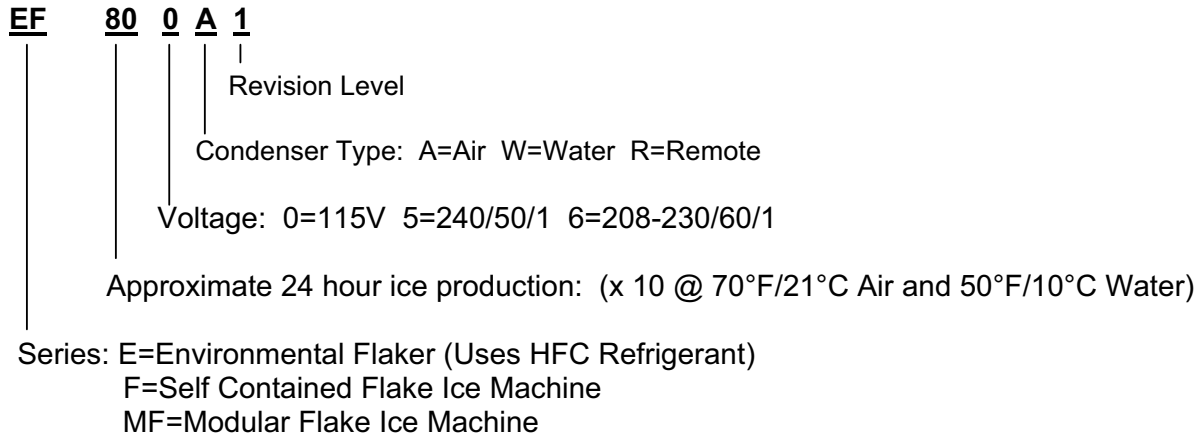

Serial Number Date Code

The first letter in the serial number indicates the month and decade of manufacture.
 The first digit in the serial number indicates the year of manufacture.

Example: A0XX-XXXXX-Z is manufactured January 2000
A1XX-XXXXX-Z is manufactured January 2001
A4XX-XXXXX-Z is manufactured January 2004

1990-1999	MONTH	2000-2009
M	JANUARY	A
N	FEBRUARY	B
P	MARCH	C
Q	APRIL	D
R	MAY	E
S	JUNE	F
T	JULY	G
U	AUGUST	H
V	SEPTEMBER	I
W	OCTOBER	J
Y	NOVEMBER	K
Z	DECEMBER	L

Note: The letter O and letter X are not used.

Model and Serial Number Format

MODEL NUMBER EMF450AS2 

SERIAL NUMBER 04071280010077 

AC SUPPLY VOLTAGE ~ 115 HERTZ 60
 TOTAL LOAD AMPS PHASE 1
 MINIMUM CIRCUIT AMPACITY 14.1 WIRES 2
 MAX FUSE SIZE OR HACR TYPE CIRCUIT BREAKER 15.0
 HEATER WATTS

MOTORS	VOLTS	RLA/FLA	W/HP	LRA
1 COMPRESSOR	115	6.9		29.0
1 FAN DRIVE	115	.8	16W	
1 AUGER	115	4.6	1/4HP	

RATED POWER CONSUMPTION (KW)
 REFRIGERANT R404A CHARGE/CIRCUIT 12 OZ 340 GRAMS
 NUMBER OF REFRIGERANT CIRCUITS 1 

DESIGN PRESSURES P.S.I. 252 -LO 450 -HI
 BARS 17.7 -LO 31.6 -HI

 LISTED 361P
 US
 ICE MAKER WITHOUT STORAGE MEANS



MILE HIGH EQUIPMENT CO.
 DENVER, COLORADO 80239
 MADE IN U.S.A.

RATED ENERGY EFFICIENCY
 (KWH/100 LB) 4.8 (KJ/KG) 396.8
 MINIMUM BIN ENERGY EFFICIENCY (%) NA
 Verified in Accordance With Energy Standard CAN/CSA 742-98 and
 ARI 810-91 by Underwriters Laboratories Inc.
 Approved City of Los Angeles Mechanical Testing Laboratory M-860074
 Accepted for use City of New York Department of Buildings MEA 37-00-E

MODEL NUMBER EMF450AS2
SERIAL NUMBER 04071280010077
 VOLTS/HERTZ/PHASE 115/60/1 MAX FUSE SIZE 15.0
 REFRIGERANT R404A CHARGE/CIRCUIT 12 OZ 340 GRAMS

 LISTED 361P
 US
 ICE MAKER WITHOUT STORAGE MEANS



Since all Enodis companies will eventually be utilizing same operating system, a company wide format for serial numbers has been designed.

This format is 14 characters long and begins with a date code followed by the ICE-O-Matic identifier, and then a sequential number. This is an entirely numerical serial number.

The new serial number will look like the example.

0407 1280 010077

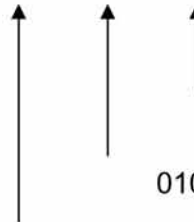

010077 is the serial identifier.

1280 is the identifier. (ICE-O-Matic)

0407 is the date code, in YYMM format. (2004 July)

The date code will change monthly and yearly to reflect the date of manufacture.

← Large data plate will be placed on the back of the unit.

← Small data plate will be placed by the service valves.

Flake Ice Machines

General Information

Electrical and Mechanical Specifications

Model Number	Production per 24 Hours @ 90°F/70°F		Compressor		Voltage	No. of wires incl ground	Minimum Circuit Ampacity	Max Fuse Size	** Refrigerant		
	Lbs	Kg	*RLA	*LRA					Type	Oz.	Grams

EF Series / 60 Hertz Machines

EF250A	319	145	5.7	30.2	115/60/1	3	12.4	15	R404A	12	340
EF450A	360	163	7.2	40	115/60/1	3	14.5	15	R404A	17	482
EF800A	616	280	10.4	51	115/60/1	3	18.2	15	R404A	20	567

EMF Series / 60 Hertz Machines

EMF450A	372	169	6.9	40	115/60/1	3	14.1	15	R404A	17	482
EMF450W	472	214	6.8	40	115/60/1	3	13.1	15	R404A	14	397
EMF800A	632	287	10.5	51	115/60/1	3	19.8	20	R404A	25	709
EMF800W	756	343	9.5	51	115/60/1	3	16.5	20	R404A	16	454
EMF1106A	816	370	4.5	34.2	208-230/60/1	3	9.4	15	R404A	34	964
EMF1106W	1008	458	4.4	34.2	208-230/60/1	3	8.5	15	R404A	15	426
EMF1106R	912	414	4.5	34.2	208-230/60/1	3	10.4	15	R404A	160	4536
EMF2306A	1808	821	8.4	61	208-230/60/1	3	14.9	20	R404A	84	2382
EMF2306W	2240	1051	7.3	61	208-230/60/1	3	12.8	20	R404A	36	1021
EMF2306R	1828	830	8.1	61	208-230/60/1	3	15.5	20	R404A	240	6804

EMF Series / 50 Hertz Machines

EMF405A	432	196	3	16.1	230/50/1	3	6.6	15	R404A	19	539
EMF705A	821	373	4.1	34.5	230/50/1	3	8.6	20	R404A	34	964
EMF1005A	1080	490	5.2	42	230/50/1	3	10	20	R404A	34	964

* R.L.A.=Rated Load Amps L.R.A=Locked Rotor Amps

** Use refrigerant charge specified on Serial Plate when charging system.

Installation Guidelines

Note: Installation should be performed by an ICE-O-Matic trained Service Technician. For proper operation of the ICE-O-Matic ice machine, the following installation guidelines must be followed. Failure to do so may result in loss of production capacity, premature part failures, and may void all warranties.

Ambient Operating Temperatures

Minimum Operating Temperature: 50°F (10°C)

Maximum Operating Temperature 100°F (38°C), 110°F (43°C) on 50 Hz. Models.

Note: ICE-O-Matic products are not designed for walk in cooler applications or outdoor installation.

Incoming Water Supply (See Plumbing Diagram for line sizing Page A7-A9)

Minimum incoming water temperature: 40°F (4.5°C)

Maximum incoming water temperature: 100°F (38°C)

Minimum incoming water pressure: 20 psi (1.4 bar)

Maximum incoming water pressure: 60 psi (4.1 bar)

Note: If water pressure exceeds 60 psi (4.1 bar), a water pressure regulator must be installed.

Drains:

Route bin drain, float drain and water condenser drain individually to a floor drain. The use of condensate pumps for draining water is not recommended by ICE-O-Matic. ICE-O-Matic assumes no responsibility for improperly installed equipment.

Water Filtration

A water filter system should be installed with the ice machine.

Clearance Requirements

Self contained air cooled ice machines must have a minimum of 6 inches (15cm) of clearance around the entire machine.

Stacking

EF and EMF Series ice machines are not designed to be stacked.

Dispenser Application

EF and EMF Series ice machines are not designed to be placed on dispensers.

Electrical Specifications

The machine must be installed on a separate circuit.

Refer to the serial plate at the rear of the ice machine or the charts on Page A5.

Adjustments

Level the machine.

Check the primary and secondary bin control for proper adjustment, Page G3.

Check the safety control for proper adjustment, Page G3.

Check the water in the water float for proper level, Page D1.

Check the water regulating valve adjustment if water cooled, Page F6.

EF Series

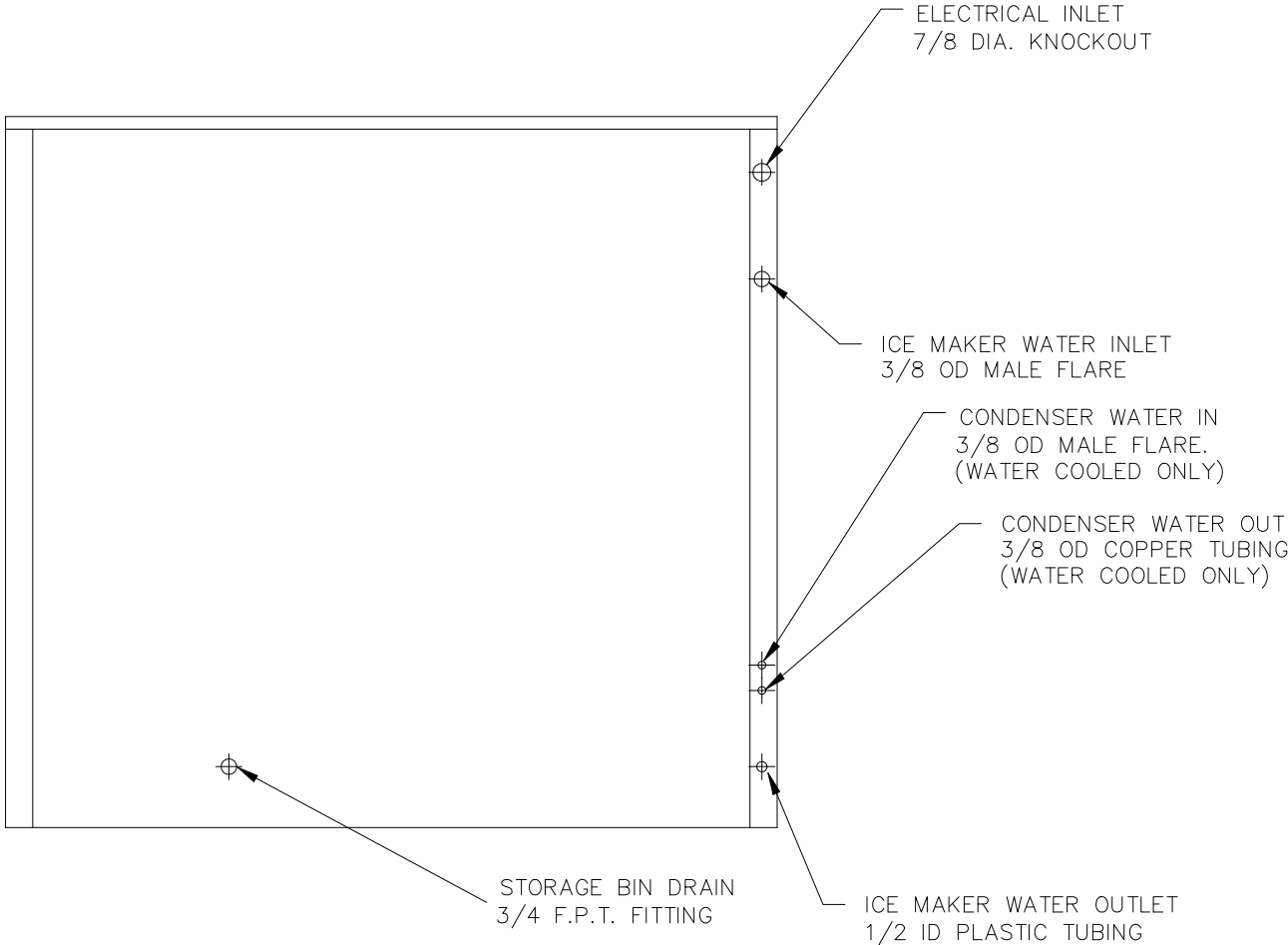

REAR VIEW

EMF Series

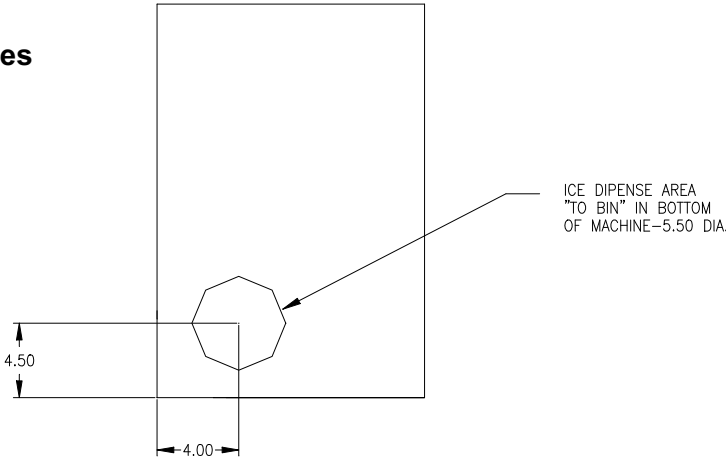

TOP VIEW

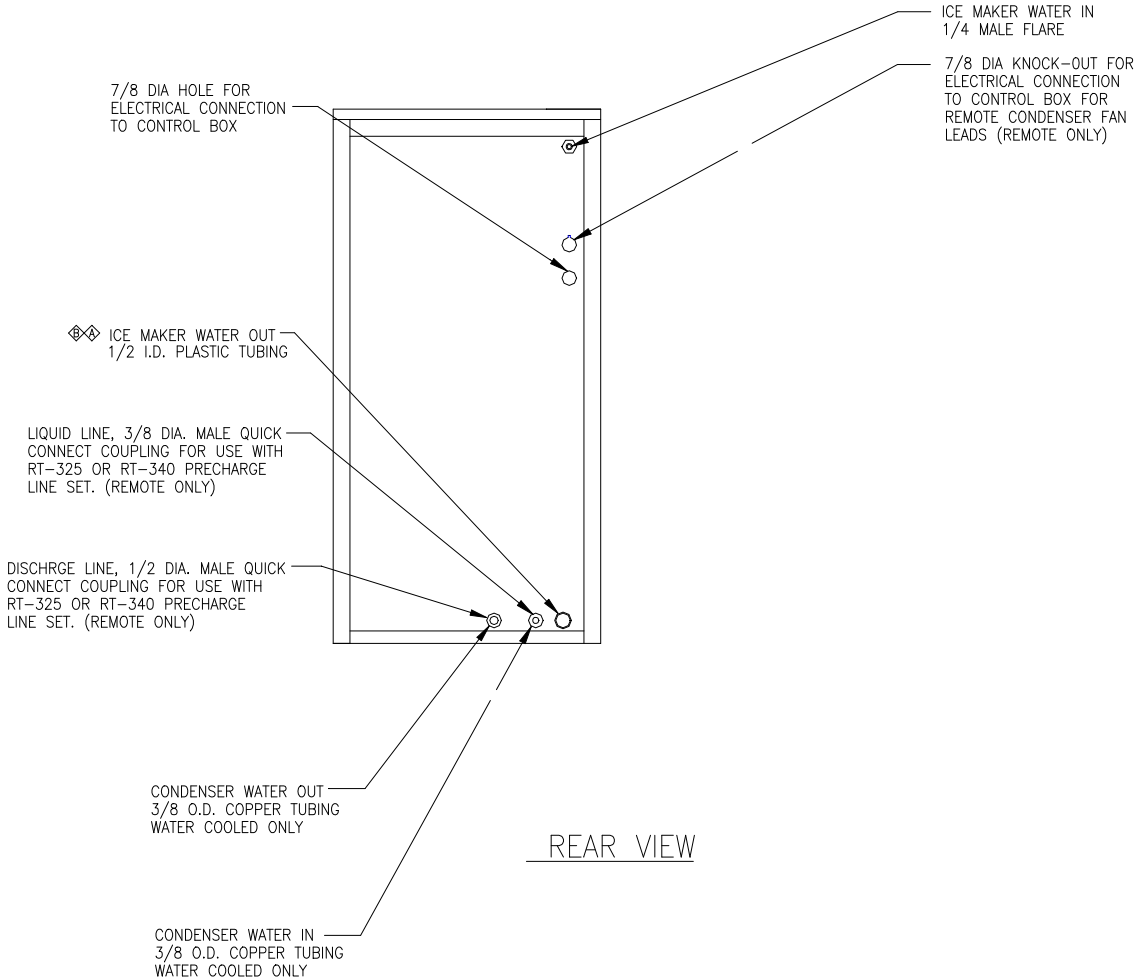

REAR VIEW

Flake Ice Machines

General Information

EMF Series (48 Inch Wide)

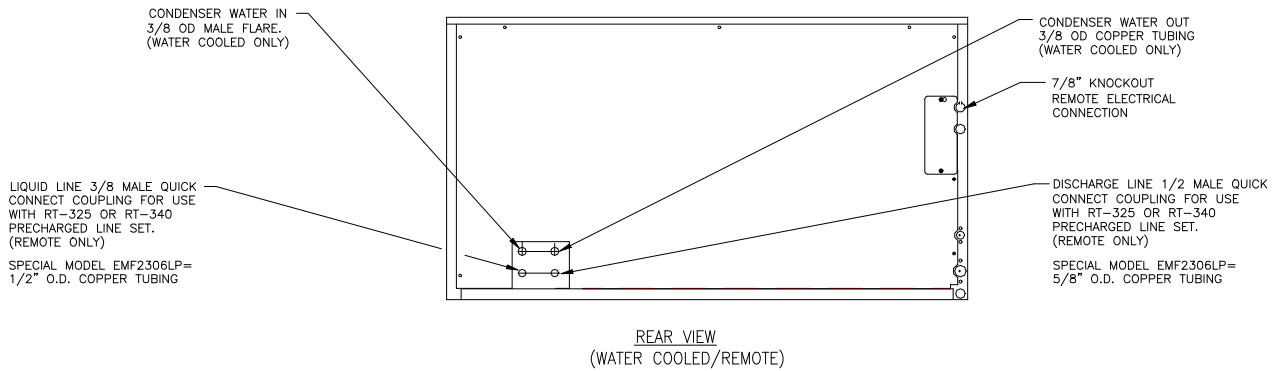
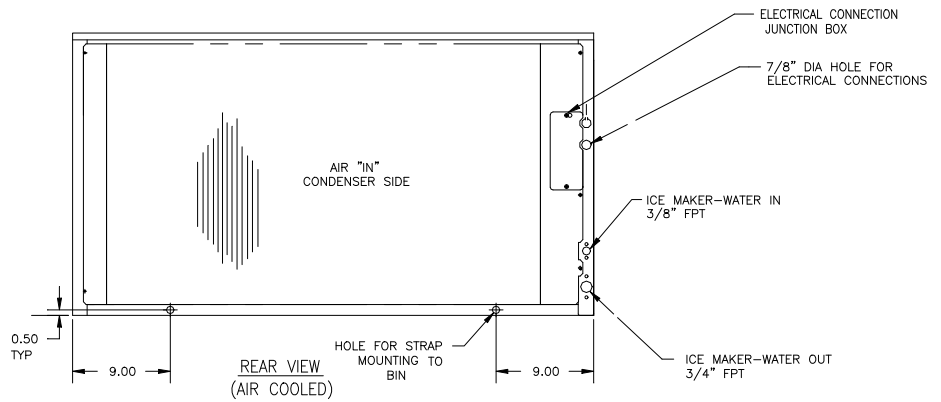
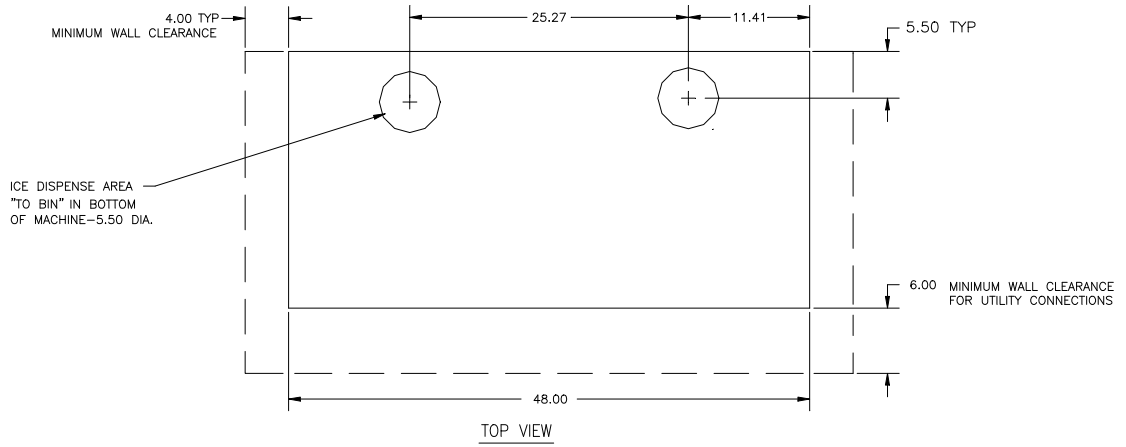

Remote Condenser Installation

The EMF1106R2 and EMF2306R2 remote ice makers incorporate the mixing valve in the condenser. This configuration allows up to a 100 foot calculated remote line set run. Reference the diagram below to calculate the maximum 100 foot line set run.

For proper operation of the ICE-O-Matic ice machine, the following installation guidelines must be followed. Failure to do so may result in loss of production capacity, premature part failure, and may void all warranties.

Remote condensers must be installed per local building codes. A two to four inch diameter roof penetration will be needed for refrigerant lines and electrical conduit. The penetration should be within two feet of where the condenser will be located. A roof jack must be installed at the penetration.

Installation Guidelines

- Ambient operating temperatures: -20°F (-28.9°C) to 120°F (48.9°C)
- Condenser Airflow: Condensers must have a vertical airflow.

<u>ICE Machine Model Number</u>	<u>Remote Condenser Model Number</u>
EMF1106R2	VRC1061
EMF2306R2	VRC2061

Limitations for new remote machines that have the headmaster mounted in the condenser.

- Maximum Rise is 35 feet.
- Maximum Drop is 15 feet.
- Maximum equivalent run is 100 feet.

Formula for figuring maximum equivalent run is as follows:

Rise x 1.7 + Drop x 6.6 + horizontal run = equivalent run.

Examples: 35 ft. rise x 1.7 + 40 ft. horizontal = 99.5 equivalent feet line run

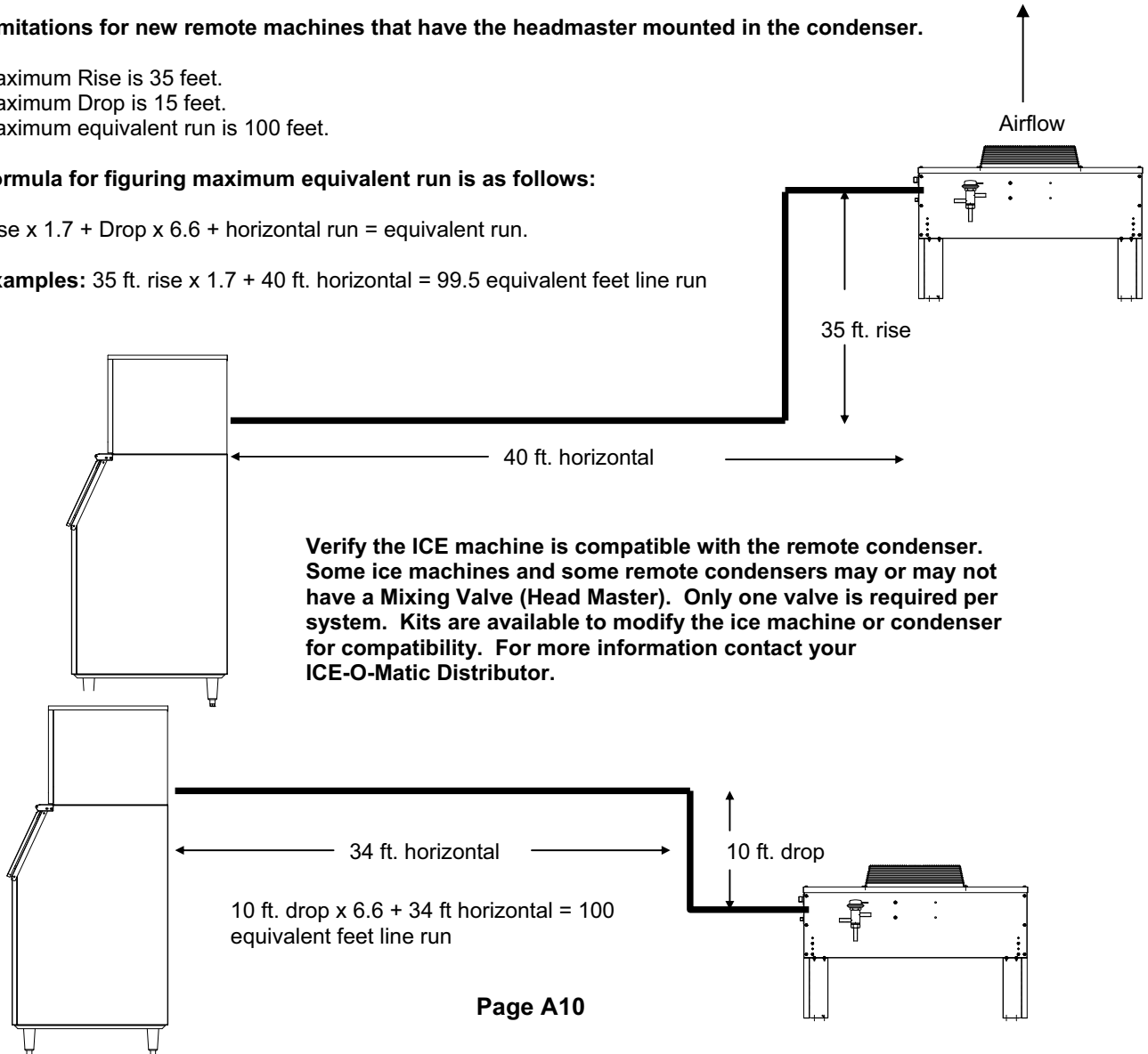

**ICE-O-Matic
Parts and Labor
Domestic & International Limited Warranty**

Mile High Equipment LLC (the "Company") warrants ICE-O-Matic brand ice machines, ice dispensers, remote condensers, water filters, and ice storage bins to the end customer against defects in material and factory workmanship for the following:

<ul style="list-style-type: none"> • Cube ice machines, compressed ice machines and remote condensers. - Thirty-six (36) months parts and labor 	<ul style="list-style-type: none"> • Ice storage bins -Twenty-four (24) month parts and labor
<ul style="list-style-type: none"> • Flake ice machines - Twenty-four (24) months parts and labor 	<ul style="list-style-type: none"> • IOD model dispensers - Twenty-four (24) months parts, Twelve (12) months labor
<ul style="list-style-type: none"> • CD model dispensers - Thirty-six (36) months parts and labor 	<ul style="list-style-type: none"> • Water filter systems - Twelve (12) months parts and labor (not including filter cartridges)

An additional twenty-four (24) month warranty on parts (excluding labor) will be extended to all cube ice machine evaporator plates and all cube ice and compressed ice machine compressors from the date of original installation. An additional thirty-six (36) month warranty on parts (excluding labor) will be extended to all flake ice machine compressors from the date of original installation. The company will replace EXW (Incoterms 2000) the Company plant or, EXW (Incoterms 2000) the Company-authorized distributor, without cost to the Customer, that part of any such machine that becomes defective. In the event that the Warranty Registration Card indicating the installation date has not been returned to ICE-O-Matic, the warranty period will begin on the date of shipment from the Company. Irrespective of the actual installation date, the product will be warranted for a maximum of seventy-two (72) months from date of shipment from the Company.

ICE-model cube ice machines which are registered in the Water Filter Extended Warranty Program will receive a total of eighty-four (84) months parts and labor coverage on the evaporator plate from the date of original installation. Water filters must be installed at the time of installation and registered with the Company at that time. Water filter cartridges must be changed every six (6) months and that change reported to the Company to maintain the extended evaporator warranty.

No replacement will be made for any part or assembly which (I) has been subject to an alteration or accident; (II) was used in any way which, in the Company's opinion, adversely affects the machine's performance; (III) is from a machine on which the serial number has been altered or removed; or, (IV) uses any replacement part not authorized by the Company. This warranty does not apply to destruction or damage caused by unauthorized service, using other than ICE-O-Matic authorized replacements, risks of transportation, damage resulting from adverse environmental or water conditions, accidents, misuse, abuse, improper drainage, interruption in the electrical or water supply, charges related to the replacement of non-defective parts or components, damage by fire, flood, or acts of God.

This warranty is valid only when installation, service, and preventive maintenance are performed by a Company-authorized distributor, a Company-authorized service agency, or a Company Regional Manager. The Company reserves the right to refuse claims made for ice machines or bins used in more than one location. This Limited Warranty does not cover ice bills, normal maintenance, after-install adjustments, and cleaning.

Limitation of Warranty

This warranty is valid only for products produced and shipped from the Company after October 1, 2006. A product produced or installed before that date shall be covered by the Limited Warranty in effect at the date of its shipment. The liability of the Company for breach of this warranty shall, in any case, be limited to the cost of a new part to replace any part, which proves to be defective. The Company makes no representations or warranties of any character as to accessories or auxiliary equipment not manufactured by the Company. REPAIR OR REPLACEMENT AS PROVIDED UNDER THIS WARRANTY IS THE EXCLUSIVE REMEDY OF THE CUSTOMER. MILE HIGH EQUIPMENT SHALL NOT BE LIABLE FOR ANY INCIDENTAL OR CONSEQUENTIAL DAMAGES FOR BREACH OF ANY EXPRESS OR IMPLIED WARRANTY ON THIS PRODUCT. EXCEPT TO THE EXTENT PROHIBITED BY APPLICABLE LAW, ANY IMPLIED WARRANTY OR MERCHANTABILITY OR FITNESS FOR A PARTICULAR PURPOSE ON THIS PRODUCT IS LIMITED IN DURATION TO THE LENGTH OF THIS WARRANTY.

Filing a Claim

All claims for reimbursement **must be received at the factory within 90 days from date of service** to be eligible for credit. **All claims outside this time period will be void.** The model, the serial number and, if necessary, proof of installation, must be included in the claim. Claims for labor to replace defective parts must be included with the part claim to receive consideration. Payment on claims for labor will be limited to the published labor time allowance hours in effect at the time of repair. The Company may elect to require the return of components to validate a claim. Any defective part returned must be shipped to the Company or the Company-authorized distributor, transportation charges pre-paid, and properly sealed and tagged. The Company does not assume any responsibility for any expenses incurred in the field incidental to the repair of equipment covered by this warranty. The decision of the Company with respect to repair or replacement of a part shall be final. No person is authorized to give any other warranties or to assume any other liability on the Company's behalf unless done in writing by an officer of the Company.

GOVERNING LAW

This Limited Warranty shall be governed by the laws of the state of Delaware, U.S.A., excluding their conflicts of law principles. The United Nations Convention on Contracts for the International Sale of Goods is hereby excluded in its entirety from application to this Limited Warranty.

Mile High Equipment LLC, 11100 East 45th Avenue, Denver, Colorado 80239 (303) 371-3737

October 2006

General Operation

A general description of the flake ice machine operation is given below. The remainder of the manual provides more detail about the components and systems.

Water enters a reservoir through the float valve and is gravity fed into the evaporator barrel through an opening in the bottom of the barrel. Water fills the evaporator to the same level as the water in the reservoir. A float valve, which stops the flow of water into the reservoir when the reservoir becomes full, maintains this water level.

When the ON/OFF switch is turned on or when the bin control closes, the auger motor energizes. The compressor is delayed for 2 to 4 minutes. After the compressor delay period, the condenser fan motor (air cooled machines only) and compressor start and the temperature of the evaporator barrel drops. The water in the evaporator freezes to the inner walls of the evaporator barrel.

A belt driven gear reducer continuously turns the auger inside the evaporator. As the auger turns, it pushes the ice upward and forces it out of the top of the barrel, through the delivery chute, and into the storage bin. As ice is pushed out through to top of the evaporator, make-up water enters the bottom of the evaporator.

Evaporator

Float

Gear Reducer

V-Belt

Auger Motor

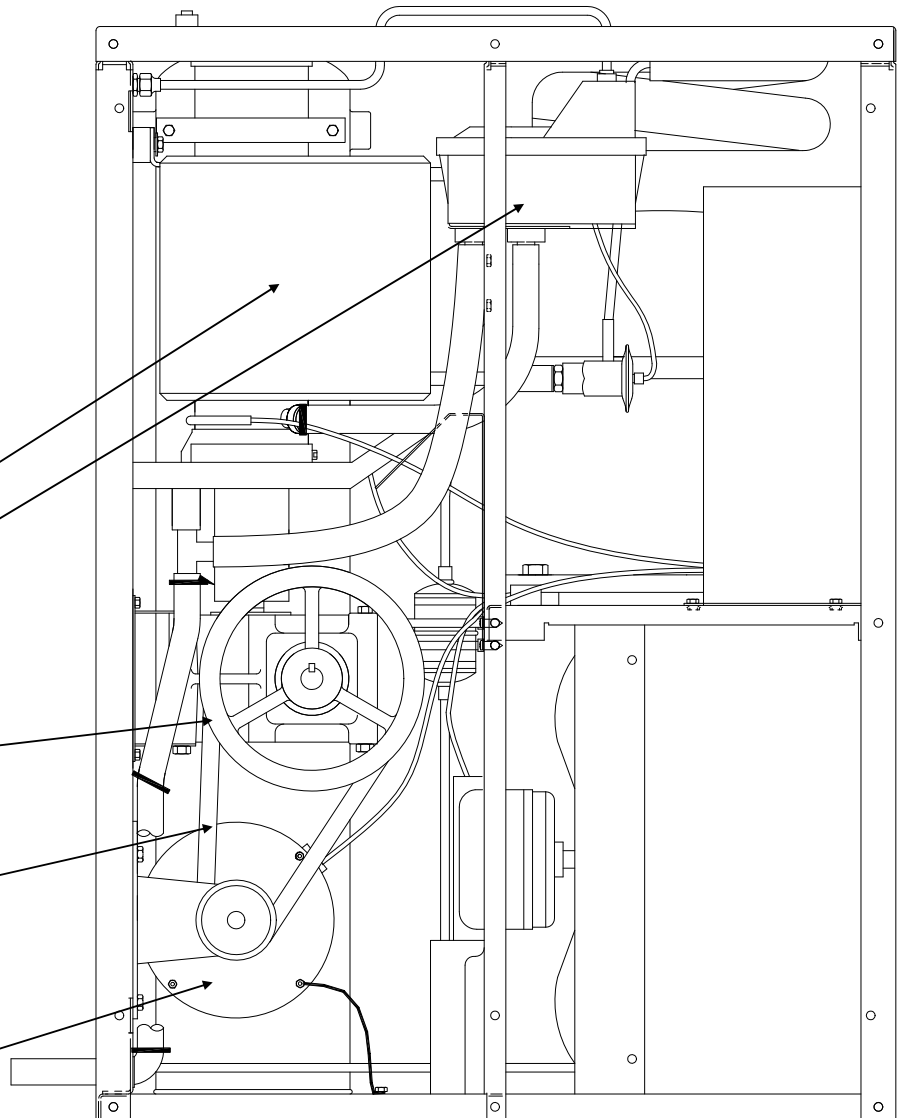

Danger!

Electrical shock and/or injury from moving parts inside this machine can cause serious injury or death. Disconnect electrical supply to machine prior to performing any adjustments or repair.

Maintenance Procedure

Warning!

Failure to perform the required maintenance at the frequency specified will void warranty coverage in the event of a related failure.

To insure economical, trouble free operation of the ice maker, it is recommended that the following maintenance be performed every 6 months by a qualified service technician.

1. Check the float reservoir for mineral build-up or check the auger drive motor amp draw to determine if the water system needs cleaning. Clean the water system, if necessary, per the instructions on Page B2. Local water conditions may require that cleaning be performed more often than 6 month intervals.
2. Check the water level in the float tank as described on Page D1.
3. Clean the condenser (air cooled machines) to insure unobstructed airflow.
4. Check for leaks of any kind, water, refrigerant, oil, etc.
5. Check the Primary Bin Control for proper adjustment as described on Page G3.
6. Check the Secondary Bin Control for proper adjustment as described on Page G4
7. Check the Safety Control for proper adjustment as described on Page G3.
8. Check the water regulating valve (water cooled machines) for proper adjustment by measuring the water temperature at the outlet of the condenser drain. It should be between 100°F (37.7°C) and 110°F (43.3°C).
9. Check the TXV bulb to make sure that it is securely fastened and properly insulated.
10. Check all electrical connections tightness. **Warning: Disconnect electrical supply.**
11. Oil the auger motor if the motor has oil fittings.
12. Check the V-Belt for wear and proper tension as described on Page E1.

CAUTION: Protective eyewear and gloves should be worn when using cleaning products.

CLEANING AND SANITIZING INSTRUCTIONS

1. Turn the machine and water supply to the float off.
2. Remove or melt all ice in the bin.
3. Prepare one gallon (3.75l) of non-chlorine ice machine cleaner i.e. Nu-Calgon Nickel Safe, as directed on container.
4. Turn the machine on, remove the float reservoir cover and add cleaning solution to the reservoir.
5. As the machine makes ice, keep the reservoir filled with the cleaning solution until the entire gallon is used up.
6. Turn the machine off.
7. Prepare 1 gallon (3.75l) of approved (U.S. FDA 21 CFR, 178-1010) food equipment sanitizer to form a solution with 100 – 200 ppm free chlorine yield. Reserve about 1/3 gallon for step #14 below.
8. Turn the machine on and add the sanitizer to the reservoir, keeping the reservoir filled with sanitizer until 2/3 gallon is used up.
9. Turn the machine off.
10. Replace the float reservoir cover and turn the water supply back on.
11. Turn the machine on and allow the machine to make ice for 15 minutes.
12. Turn the machine off and remove and discard all of the ice from the bin made during the cleaning operation.
13. Clean the inside of the bin, bin door, and door frame with warm soapy water and rinse.
14. Using the remainder of the sanitizing solution, wipe all areas of the bin liner, door and door frame, etc. and rinse.
15. Turn machine back on.

Winterizing Procedures

Important!

Whenever the ice machine is taken out of operation during the winter months, the procedure below must be performed. Failure to do so may cause serious damage and will void all warranties.

1. Turn off water to machine.
2. Make sure all ice is out of the evaporator(s)
3. Place the ON/OFF switch to the “**OFF**” position.
4. Disconnect the tubing between the evaporator and water float.
5. Drain the water system completely.
6. On water cooled machines, hold the water regulating valve open by prying upward on the water valve spring with a screwdriver while using compressed air to blow all the water out of the condenser.
7. Remove all of the ice in the storage bin and discard.

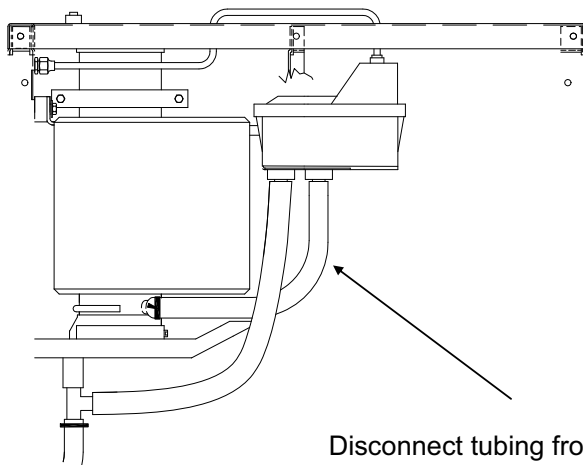

Disconnect tubing from float to evaporator and drain water from the evaporator

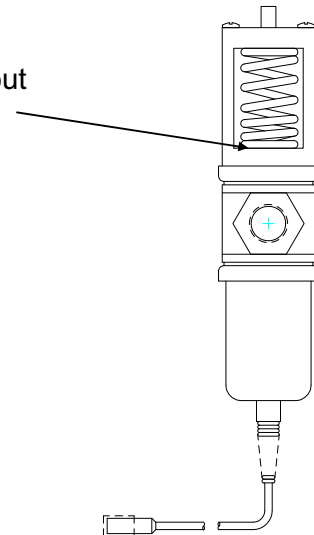

Cleaning Stainless Steel

Commercial grades of stainless steel are susceptible to rusting. It is important that you properly care for the stainless steel surfaces of your ice machine and bin to avoid the possibility of rust or corrosion. Use the following recommended guidelines for keeping your stainless steel looking like new:

- 1. Clean the stainless steel thoroughly once a week.** Clean frequently to avoid build-up of hard, stubborn stains. Also, hard water stains left to sit can weaken the steel's corrosion resistance and lead to rust. Use a nonabrasive cloth or sponge, working with, not across, the grain.
- 2. Don't use abrasive tools to clean the steel surface.** Do not use steel wool, abrasive sponge pads, wire brushes or scrapers to clean the steel. Such tools can break through the "passivation" layer - the thin layer on the surface of stainless steel that protects it from corrosion.
- 3. Don't use cleaners that use chlorine or chlorides.** Don't use chlorine bleach or products like Comet to clean the steel. Chlorides break down the passivation layer and can cause rusting.
- 4. Rinse with clean water.** If chlorinated cleansers are used, you must thoroughly rinse the surface with clean water and wipe dry immediately.
- 5. Use the right cleaning agent.** The table below lists the recommended cleaning agents for common stainless steel cleaning problems:

Cleaning Activity	Cleaning Agent	Method of Application
Routine cleaning	Soap, Ammonia, Windex, or detergent with water. Fantastik, 409 Spic'nSpan Liquid are also approve for Stainless Steel.	Apply with a clean cloth or sponge. Rinse with clean water and wipe dry.
Removing grease or fatty acids minutes.	Easy-Off or similar oven cleaners.	Apply generously, allow to stand for 15-20 Rinse with clean water. Repeat as required.
Removing hard water spots and scale.	Vinegar	Swab or wipe with clean cloth. Rinse with clean water and dry.

How To Use The Troubleshooting Trees

The troubleshooting trees were developed to be used in conjunction with the service information in the sections that follow. If used together as intended, these two parts of the manual will allow the ice machine service technician to quickly diagnose many of the problems encountered with the ice machines. When used as designed, the troubleshooting trees can lead you from a general symptom to the most likely component to suspect as the cause of the problem. The trees are not designed to be “parts changer guides”: please do not use them as such.

Components returned to the factory for warranty are tested by the factory and will not be covered under the warranty policy if they are not defective.

The troubleshooting trees are made of three types of boxes:

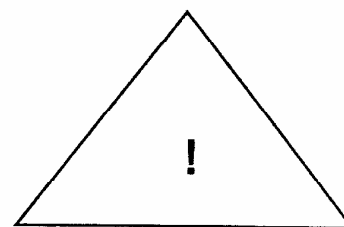
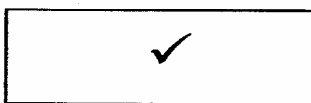
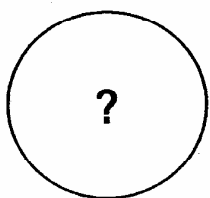

QUESTION boxes (Circle) ask a yes/no question and the answer will lead to either another question box, a check box or a solution box.

CHECK boxes (Rectangle) will suggest a point to check for proper operation, and will often refer you to a page in the service information sections of this manual. The result of the check may lead to another box, or a solution box.

SOLUTION boxes (Triangle) suggest the most likely component to cause the malfunction described in the heading of the tree. When reaching a solution box, **DO NOT** immediately assume the component is defective. The final step is to verify that the component is indeed defective, by using the service information in the sections that follow.

To use the troubleshooting trees, first find the page with the heading describing the type of problem occurring. Begin at the top of the page and follow the tree, step-by-step. When a check box is reached, it may be necessary to refer to another section in the manual.

Once a solution box is reached, refer to the appropriate section to verify that the component in the solution box is, indeed, the problem. Adjust, repair or replace the component as necessary.

Machine Runs, Does Not Make Ice

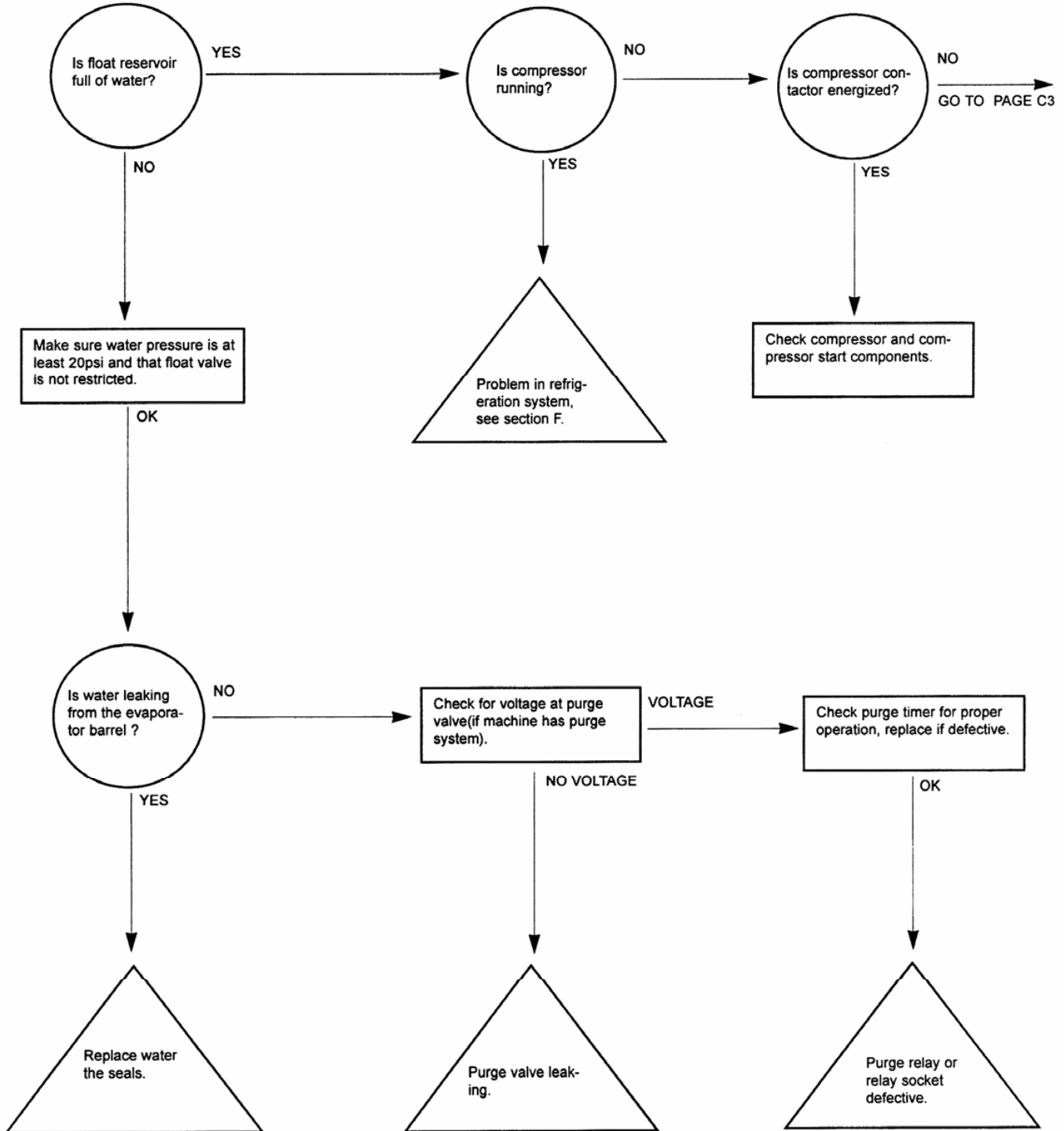

Machine Runs, Does Not Make Ice

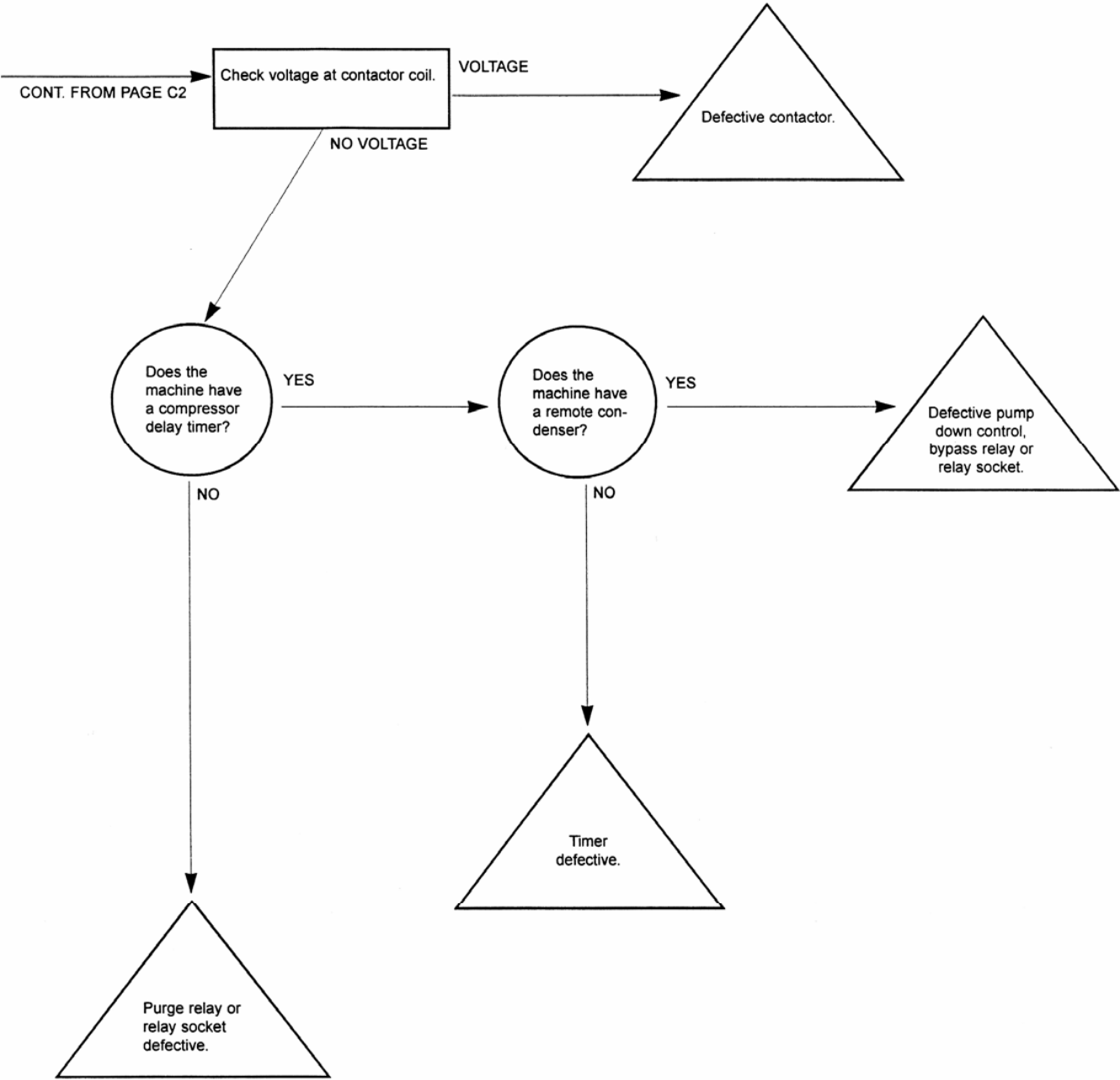

Machine Does Not Run

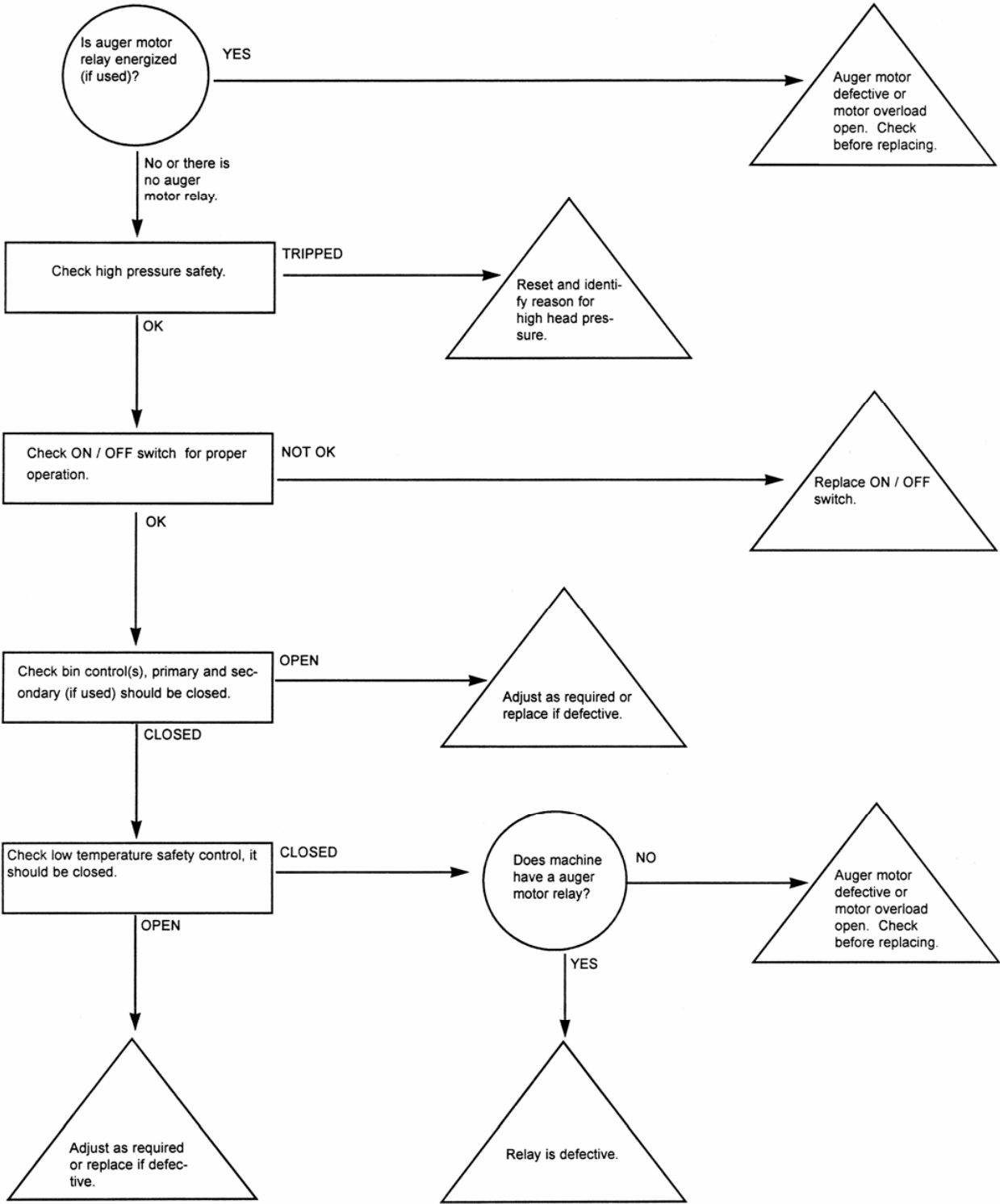

Slow Production

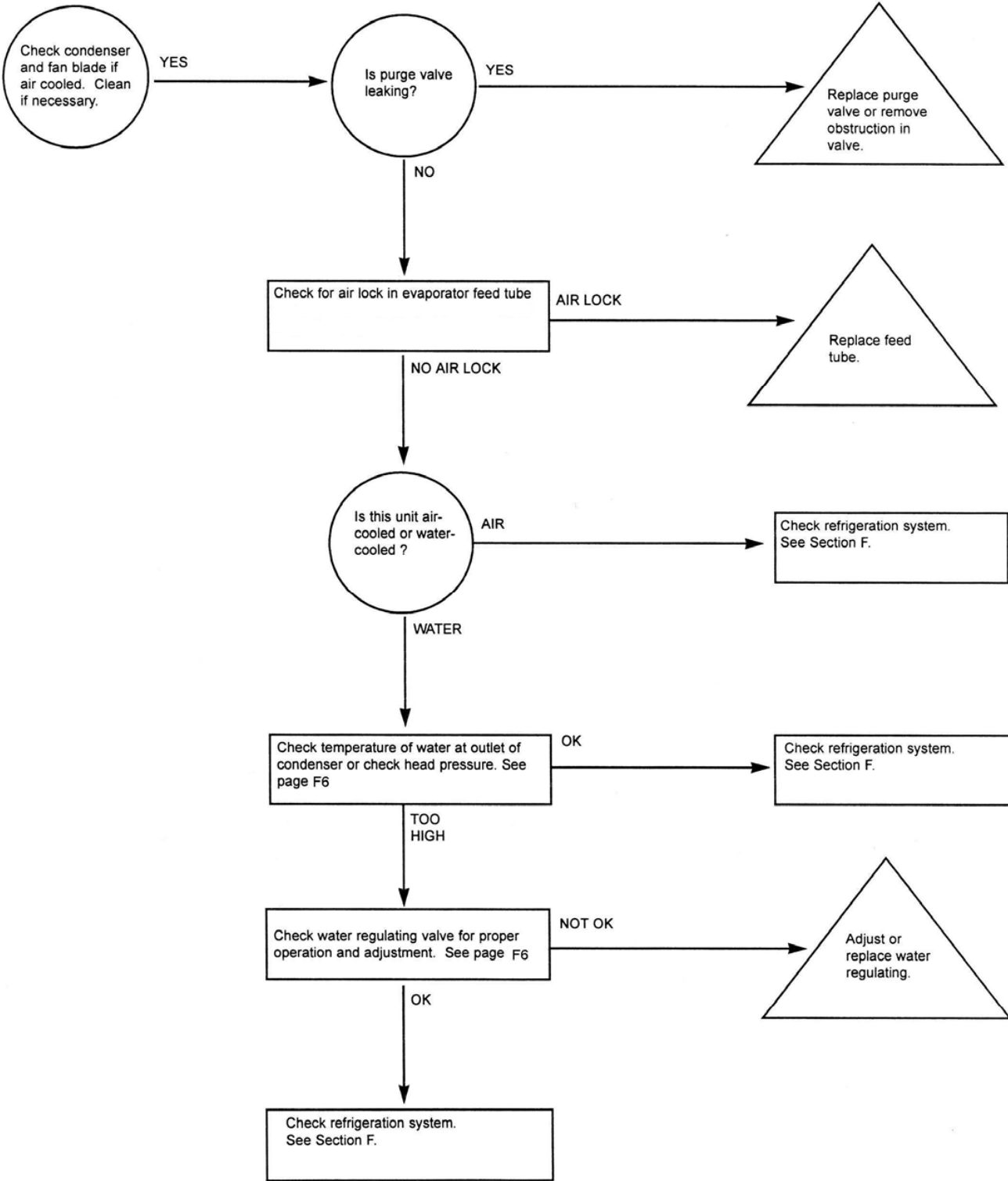

Low Production

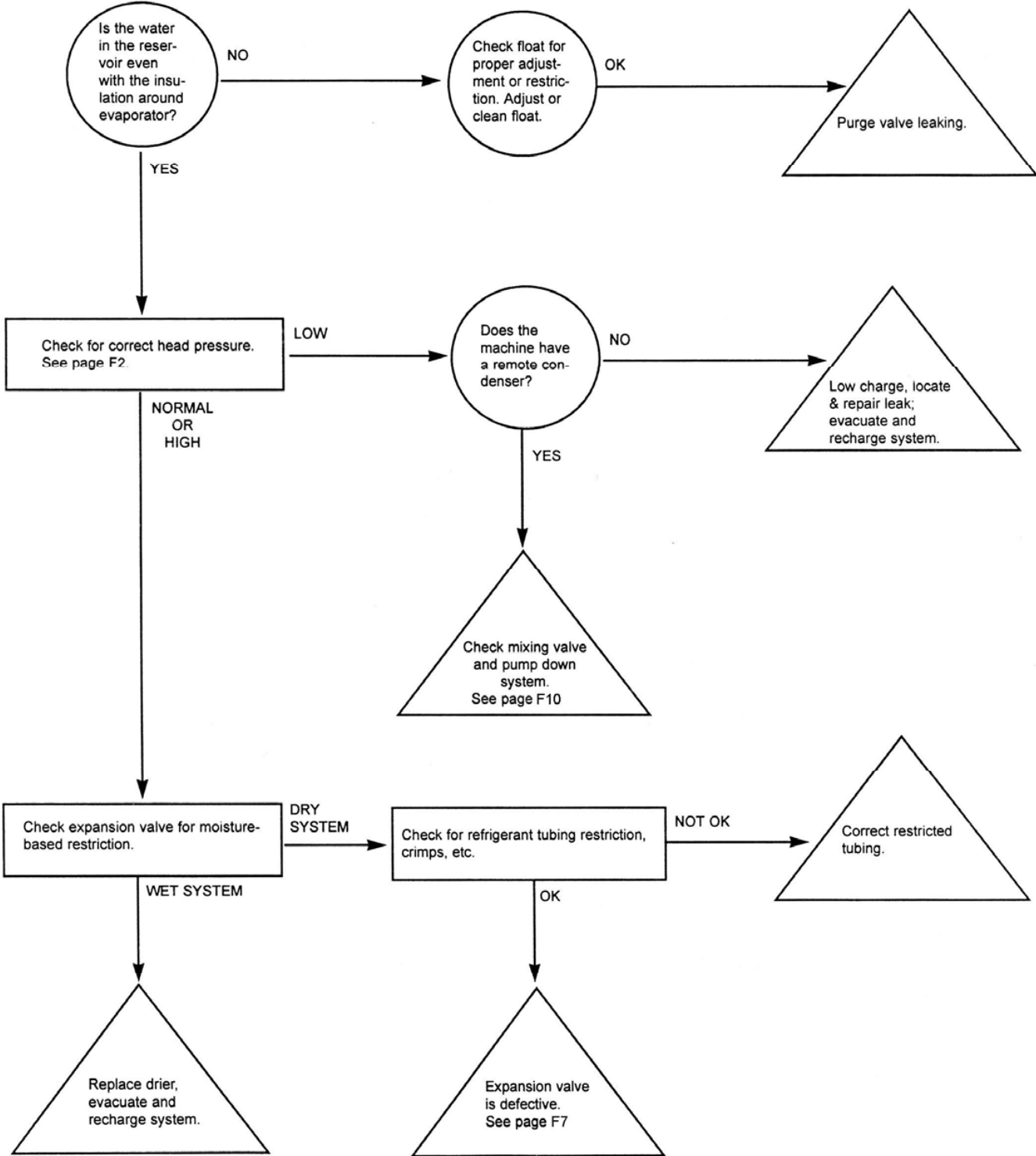

High Suction Pressure

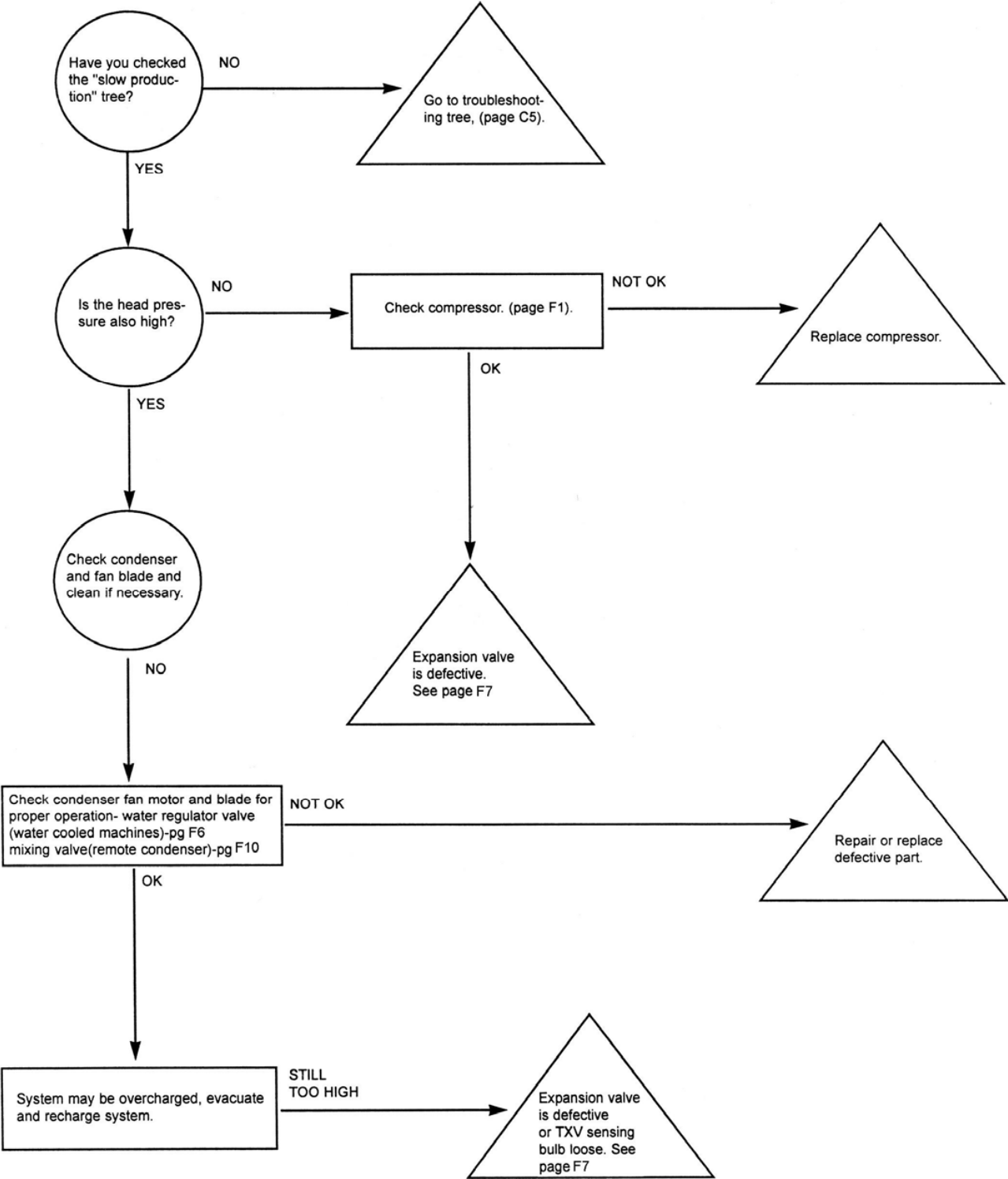

Machine Freezes Up (Auger Seizes)

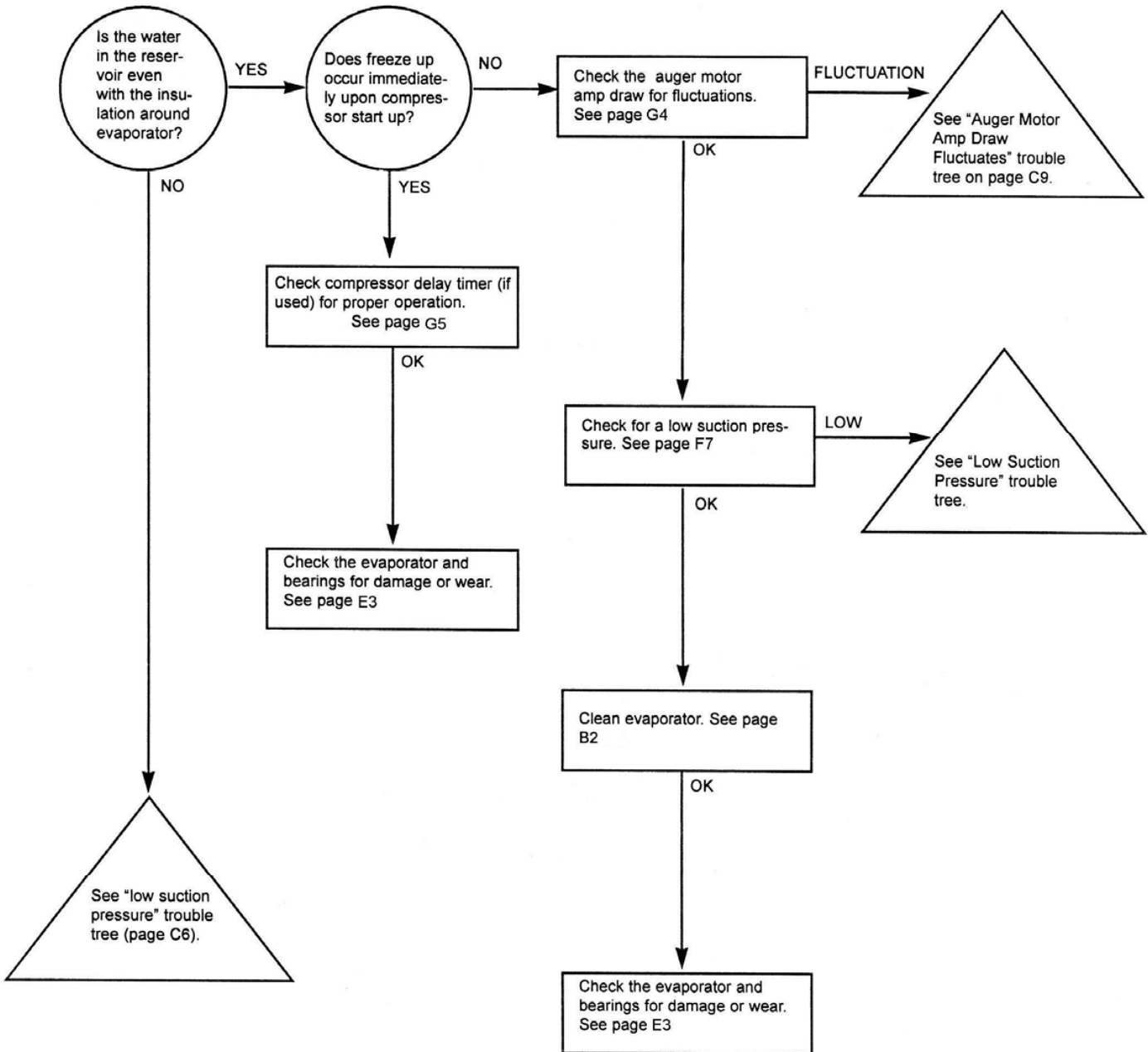

Auger Motor Amp Draw Fluctuates

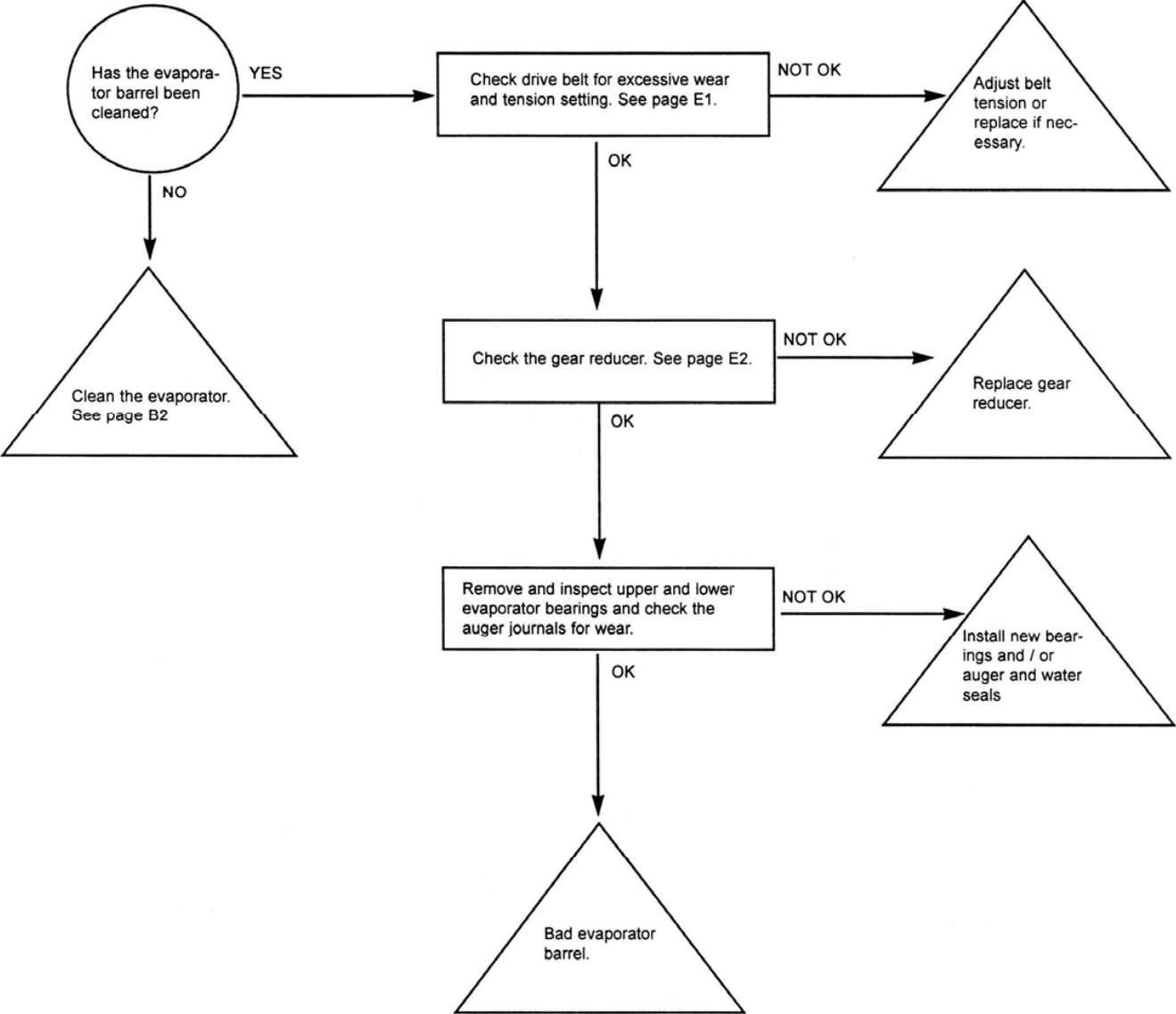

Water Leaking From Bottom of Evaporator

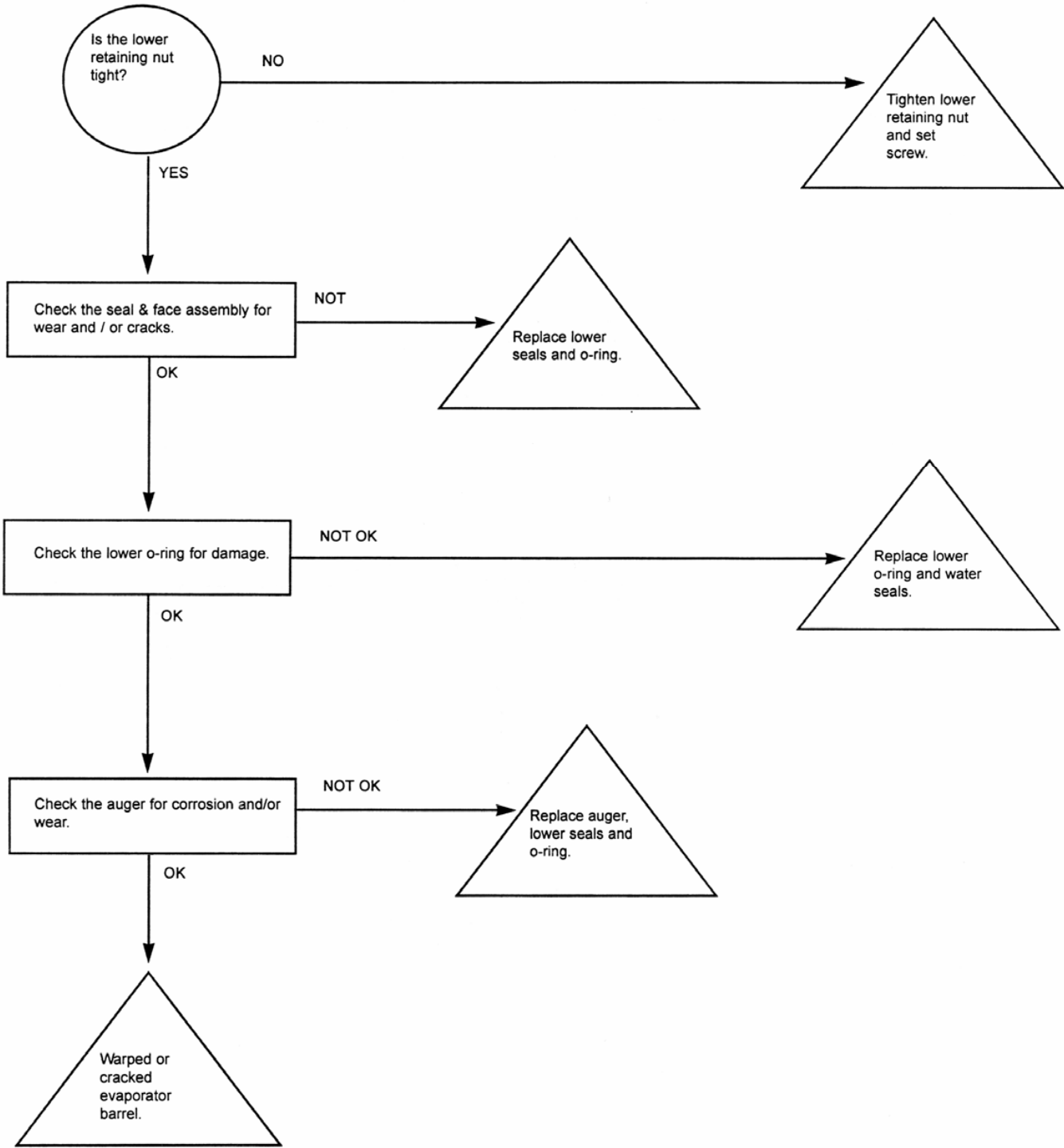

Machine Produces Wet Ice

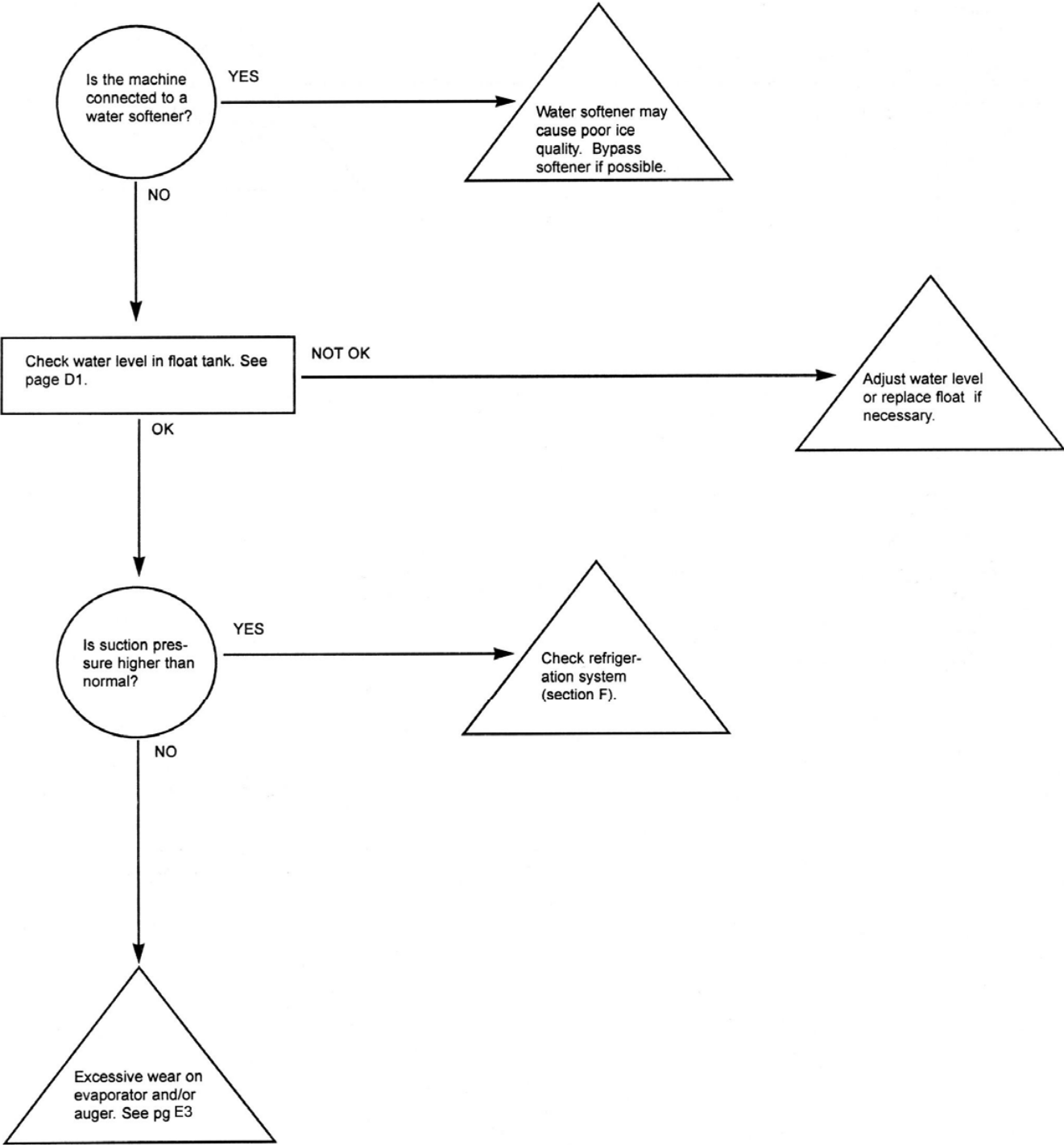

Hot Evaporator, Low Suction Pressure and Discharge Pressure (Remotes Only)

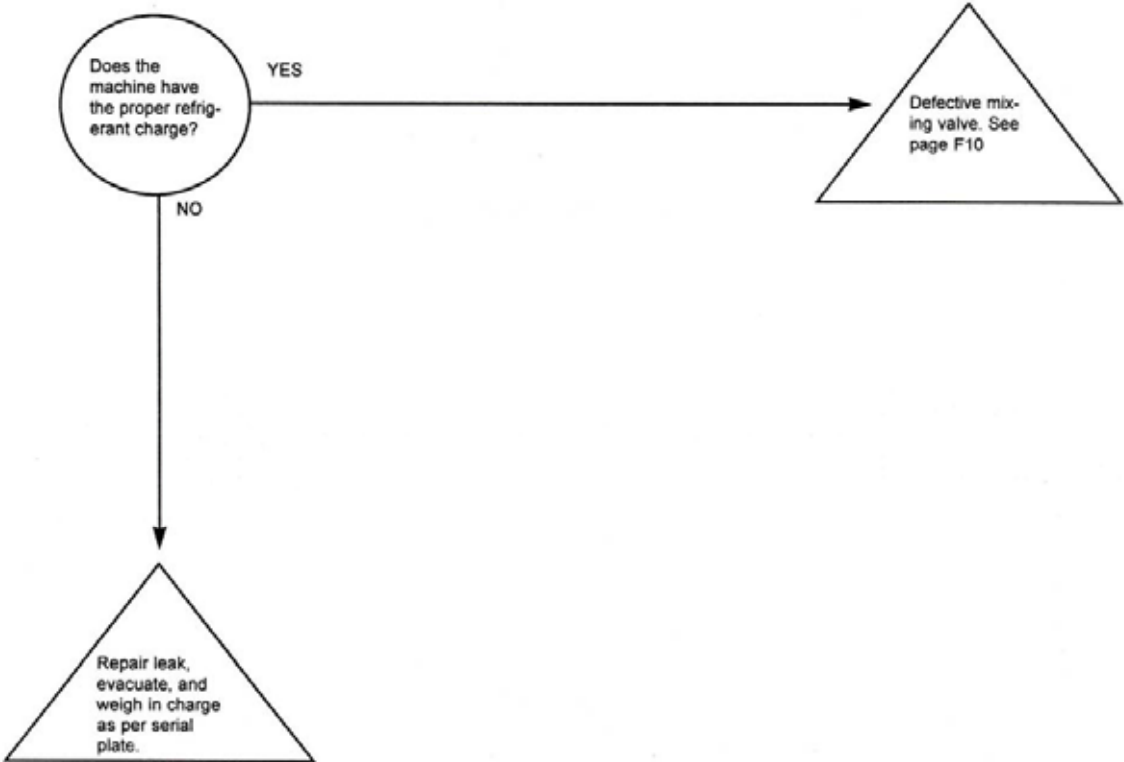

Noise Coming from Evaporator

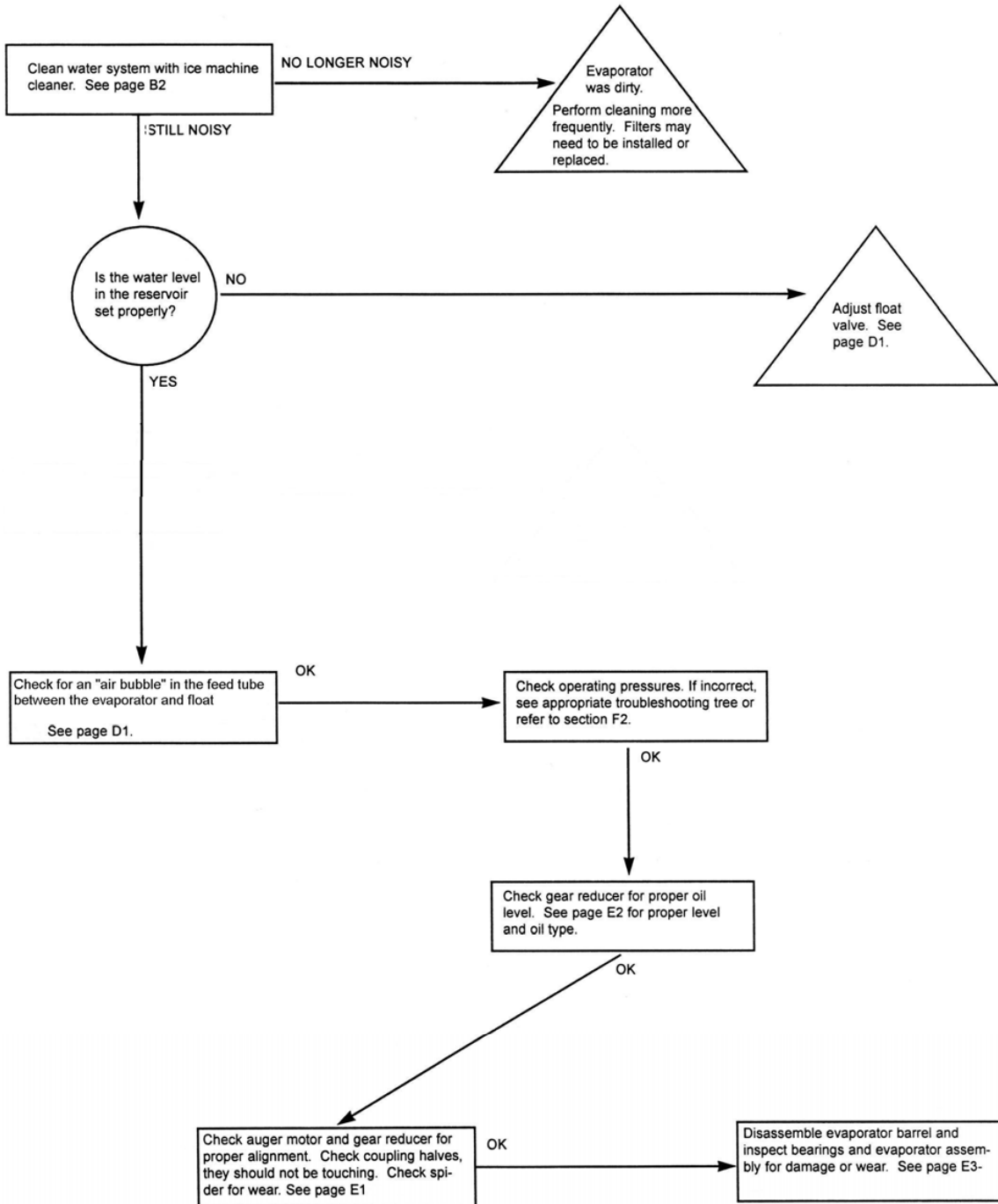

Water System

The water system in the flaker uses a floated operated valve that maintains the water level in the evaporator barrel during ice making.

Float Valve and Reservoir

Water enters the machine through the float valve located in the water reservoir and is gravity fed into the evaporator barrel through the water inlet tube. As the evaporator fills with water, the inlet tube and reservoir will fill to the same level. When the evaporator is full and the machine is off, water will lift the float ball, stopping the flow of water approximately $\frac{1}{4}$ inch before overflowing the reservoir. The float valve can be adjusted by bending the arm attached to the float ball.

While the machine is making ice, the float valve should maintain the water level so that is $\frac{1}{4}$ inch below the top insulation surrounding the evaporator barrel. The water in the evaporator will also be at this level. It is important that the water be maintained at this level for proper operation of the machine.

If the water level is too high, water at the top of the evaporator will not freeze and wet ice will result. If the water level is too low, ice will freeze harder than normal, putting excessive load on the drive system.

To adjust the water level in the evaporator, turn the machine on and wait for the machine to begin making ice. Loosen or remove the two (2) screws securing the float reservoir bracket to the frame.

Raise or lower the reservoir so that the water level is even with the top of the insulation surrounding the evaporator. Resecure the reservoir at this level.

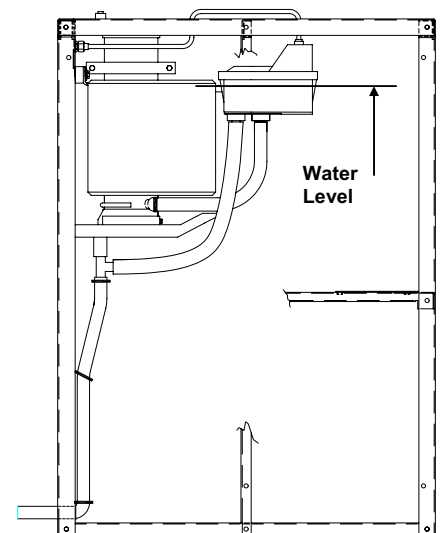
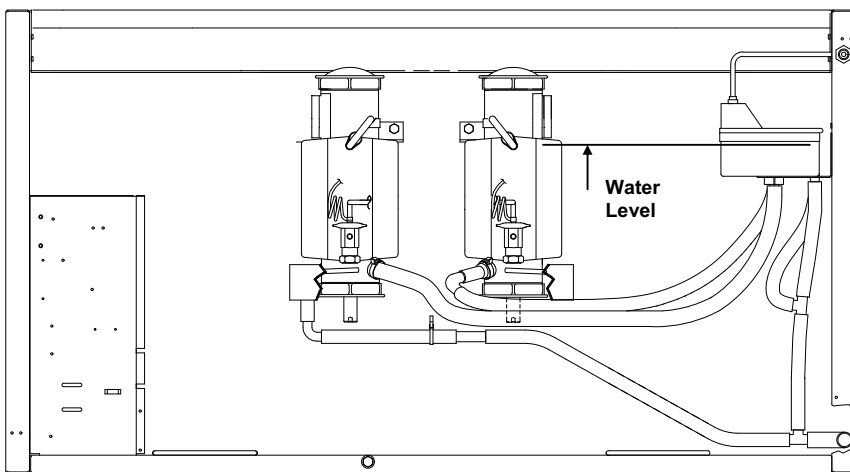

Water Seal and Lower O-Ring

The water seal is located in the bottom of the evaporator and prevents water from leaking out of the evaporator. The water seal consists of two (2) components: the seal and the seal face.

The seal is fitted into the lower bearing housing and the seal face fits around the auger shaft with the rubber side seating against the bottom of the auger. When the water seal assembly is in place, the top of the seal presses against the seal face. If the water seal fails, water will usually leak between the lower bearing and the auger shaft. See Page E6 for water seal replacement procedure.

Note: The water seal is available only as a complete assembly. Both seal and seal face must be replaced together.

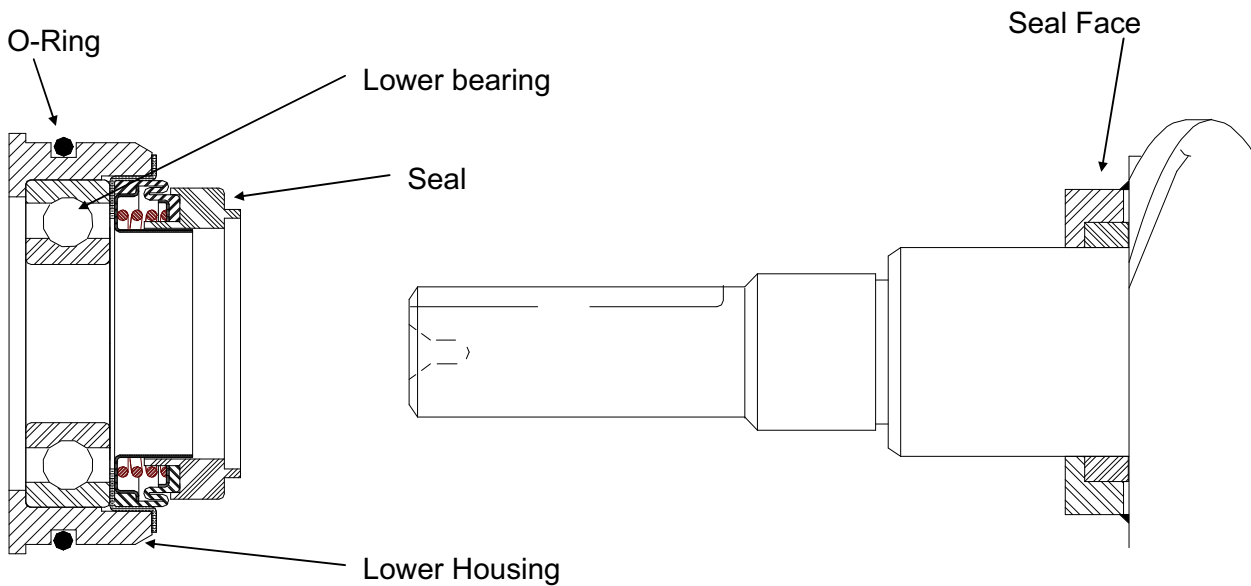

Drip Boot

The drip boot is located at the bottom of the evaporator to catch condensation from the evaporator. A water seal leak will not drain into the drip boot since the water will track down the auger shaft.

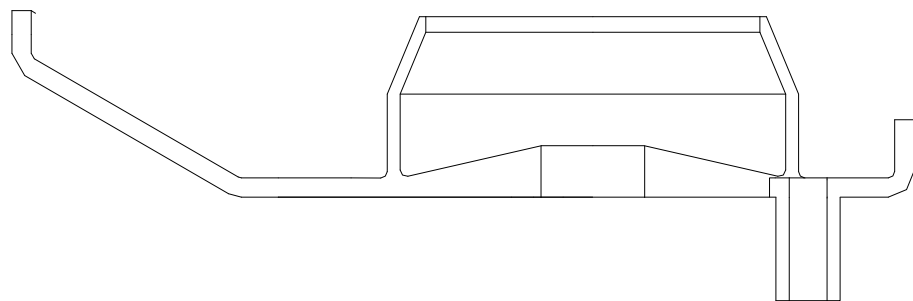

Note: Too cold of water temperature (below 50°F) and improper water level are two of the most common problems for flakers, causing low production, too hard and/or wet ice.

Drive System

The drive system consists of all components used to turn the auger. The auger drive motor turns the gear reducer via a V-Belt. A coupler is used to connect the gear reducer to the auger. The auger is located in the evaporator and is supported by two bearings, one at each end.

Auger Drive Motor and V-Belt

When facing the shaft, the auger motor should turn counter clockwise. A pulley on the shaft of the motor holds one end of the V-Belt, which is used to connect the auger motor to the input shaft of the gear reducer.

The pulley on the auger drive motor must be aligned with the pulley on the input shaft of the gear reducer. This can be checked by placing a straight edge across the face of the two pulleys. If out of alignment, the pulleys can be repositioned by loosening the setscrew that holds the pulley to the shaft, realign the pulleys and then retighten the setscrew.

The V-Belt can be adjusted by loosening the four (4) auger motor mounting bolts and moving the motor until the proper belt tension is achieved. The belt should be adjusted so that it will flex approximately $\frac{1}{2}$ inch when applying slight pressure to the center of the belt. If the V-Belt is too tight, it will put an excessive load on the auger motor and gear reducer. If the V-Belt is too loose, it may slip and reduce ice production.

Auger motors should be oiled once a year with approximately 4 to 5 drops of SAE 20 oil in each bearing.

Note: Models with two evaporators use a single drive motor with a shaft on each end of the drive motor.

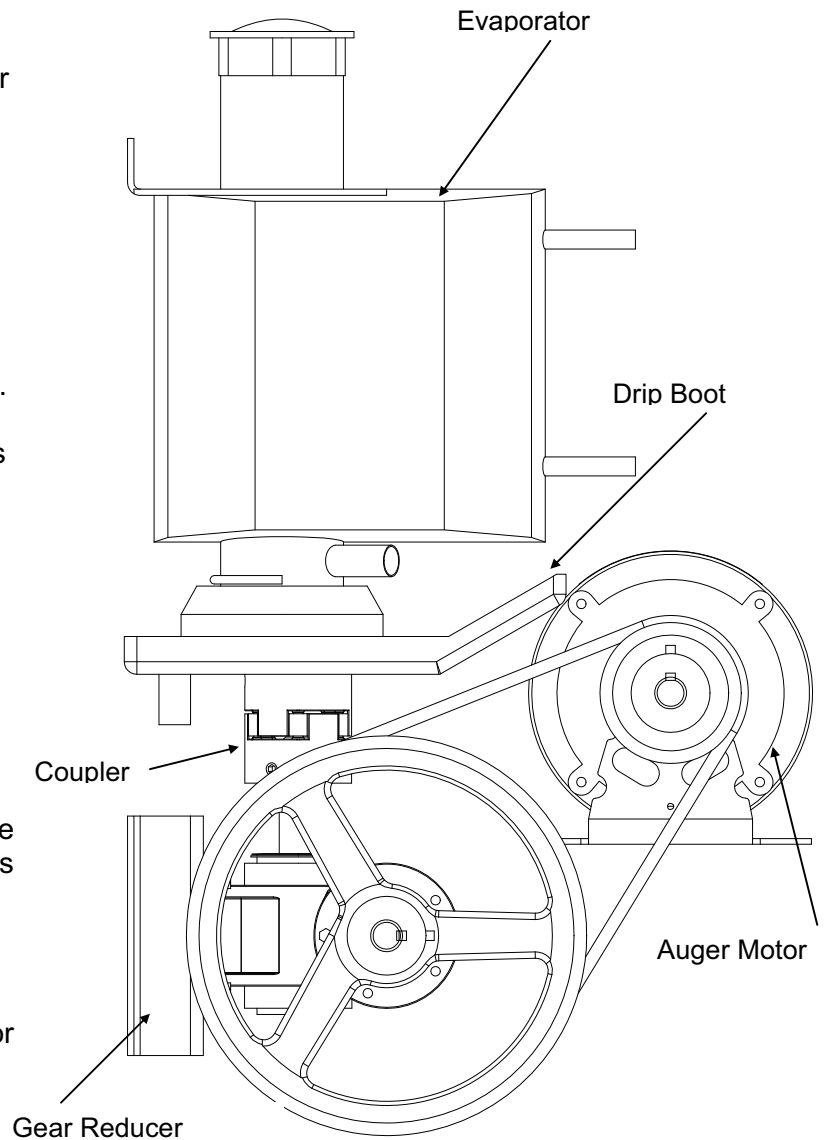

Gear Reducer

The gear reducer transfers torque to the auger. The auger drive motor turns the input shaft of the gear reducer at a high rate of speed. The input shaft turns a worm (screw type gear) that meshes with a worm gear (bronze gear). The worm gear turns the output shaft at a reduced speed.

The gear reducer should be inspected for oil leakage, noise, and vibration during scheduled maintenance of the machine. If the gear reducer is noisy, vibrating or seizing, the oil level may be low, internal parts may be worn, or the gear reducer may be under excessive load due to a problem in the evaporator. If a problem is found with the gear reducer, it must be replaced.

If the gear reducer is damaged, it may bind or lock up causing the auger motor to shut off on overload. This is usually caused by a damaged worm gear due to lack of lubricant or excessive loading of the gear reducer.

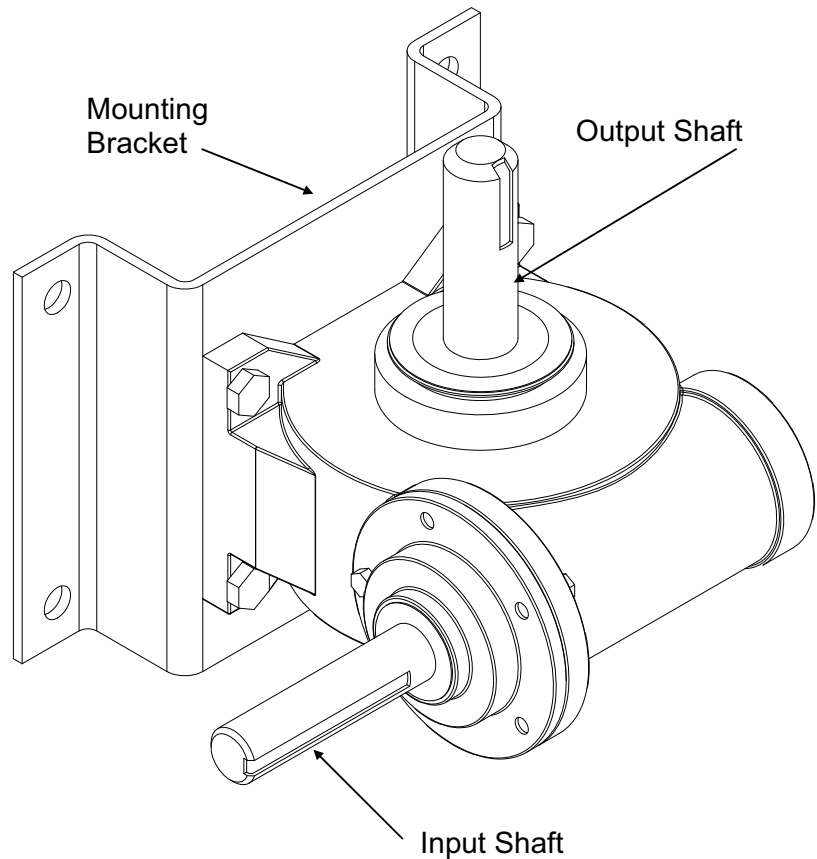

Note: There are no serviceable parts available for the gear reducer. The 9171010-03 Gear Reducer is a sealed component and does not require service.

Coupler

The coupler is a three piece assembly used to connect the gear reducer to the auger. The coupler includes the upper half, lower half and the nylon “spider” which fits between the teeth of the coupling halves, preventing metal to metal contact of the coupling teeth.

There should be an 1/8 inch gap between the coupler halves. The “spider” should fit tightly between the coupling teeth. If there is excessive play between the coupling halves, the “spider” should be inspected for wear and replaced.

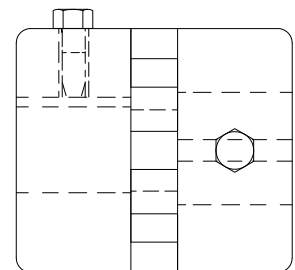

Evaporator and Internal Components

The evaporator assembly includes the evaporator and all of its internal components. The internal components consist of the upper and lower bearings and housings, water seal assembly, upper and lower O-Rings, auger, and upper and lower nuts.

The evaporator assembly will need to be disassembled for inspection or repair if one or more of the following conditions exist.

- Metal particles in the ice.
- Grease in the ice.

Follow the appropriate troubleshooting tree in Section C for the following symptoms before disassembling the evaporator.

- Water leaking from the bottom of the evaporator assembly.
- Auger seizing up.
- Auger motor amp draw fluctuating more than 4/10 of an amp with proper line voltage.
- Noise coming from the evaporator assembly.

Evaporator Disassembly

It is recommended that the entire evaporator be disassembled and inspected whenever a problem occurs in the evaporator.

Disconnect electrical power and shut off the water supply to the ice machine.

Remove the condensation cap (insulation) and ice chute from the top of the evaporator.

On EF models, remove the top panel and disconnect the wires from the secondary bin control and remove the bin control cap tube from the brass tube.

Drain the evaporator by disconnecting the water feed tube from the float to the evaporator.

On EF models, remove the chassis from the cabinet by disconnecting the water and drain lines and the incoming electrical at the cabinet junction box. Remove the chassis mounting bolts and slide the chassis out of the cabinet.

Remove the drive belt and inspect for cracks or damage.

Remove the gear reducer by removing the (4) bolts holding the gear reducer to the frame. Inspect the spider located between the coupling halves.

Remove the upper coupling half from the auger by using a ½ wrench to loosen the 5/16 bolt and pulling the coupler half off of the auger shaft. If the coupler half is seized to the auger shaft, remove the bolt and spray lubricant into the bolthole. Let the lubricant soak, then use a puller to remove the coupler half. Do not pry or use a hammer on the coupler as damage may result.

Remove the drain tube from the drip boot and remove the drip boot by pulling down on one side and working the boot off of the evaporator lower retaining nut.

Remove the upper evaporator retaining nut by using a chain wrench (wrap chain around the upper part of the nut) to loosen the nut. **Setscrews are not used on the upper nut.** (Right Hand Thread)

Caution: Do not use a hammer and chisel to loosen the nut, as damage will result.

Remove the auger and upper bearing housing assembly by tapping upward on the auger shaft with a rubber mallet, or place a block of hardwood against the auger shaft and tap upwards on the block with a hammer. Remove the upper bearing housing from the auger by removing the mounting bolt and washer.

Caution: Do not hit the auger shaft with a metal hammer, as damage to the auger shaft will result.

Remove the seal face from the auger by prying it off with a screwdriver.

Remove the lower evaporator retaining nut by first using an 1/8 inch Allen wrench to remove **the two (2) 1/4 inch set screws** from the lower nut. Remove the lower evaporator retaining nut by using a chain wrench (wrap chain around the lower part of the nut) to loosen the nut. (Right Hand Thread)
Caution: If the two (2) sets screws are not removed, damage to the evaporator threads will result.

Remove the lower bearing housing assembly from the evaporator barrel by placing a dowel, approximately 18 inches long, against the lower bearing and tapping lightly on the dowel until the bearing housing is removed from the evaporator.

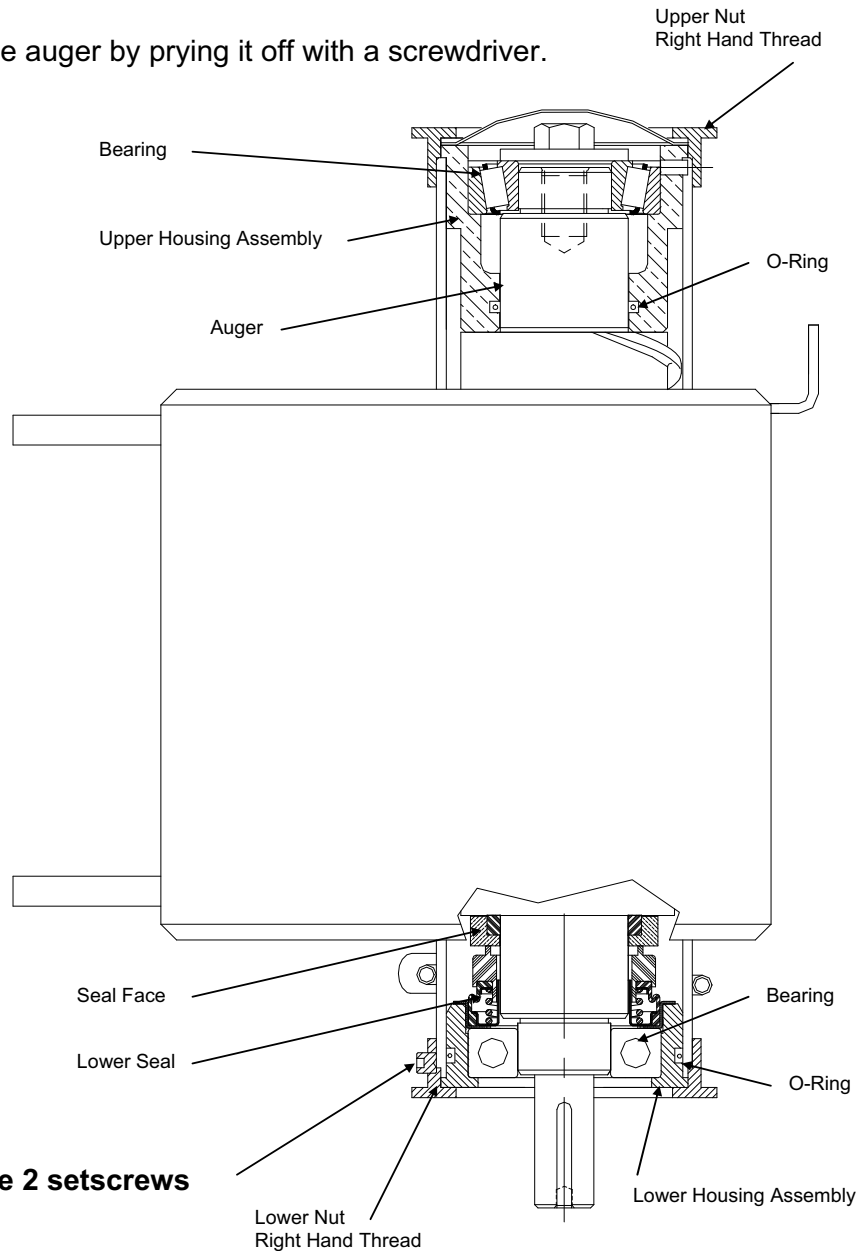

Evaporator Barrel and Auger Inspection

Inspect the evaporator for damage around the dispense opening. If it is cracked or bulged outward, it is probably due to a bin control failure. Check both bin controls for proper adjustment and operation before the machine is put back into service.

Inspect the interior of the evaporator barrel for damage. The interior of the evaporator should be smooth and have no scoring or damage due to the auger coming in contact with the evaporator side. If damage is present, the evaporator will require replacement. The evaporator is available as an assembly, which includes all internal components, or is available as the evaporator barrel only, which does not include the internal components.

Clean the auger and inspect for corrosion or wear. If the auger is corroded or if the flights are worn from contact with the evaporator walls, it should be replaced.

The auger bearing journals can be checked for wear by using hand pressure to install a new bearing onto the journals. The bearing should fit tightly around the journal. If the bearing does not fit tight, the auger is worn and must be replaced or machined to the proper size.

Augers used in the 3 inch diameter evaporators should have a journal diameter between 1.1803 and 1.1809 inches for both the upper and lower journals.

Augers used in the 2 1/2 inch diameter evaporators should have an upper journal diameter between .9831 and .9836 inches and the lower journal diameter between .7492 and .7498 inches.

Vertical Score Lines Guide the Ice Upward

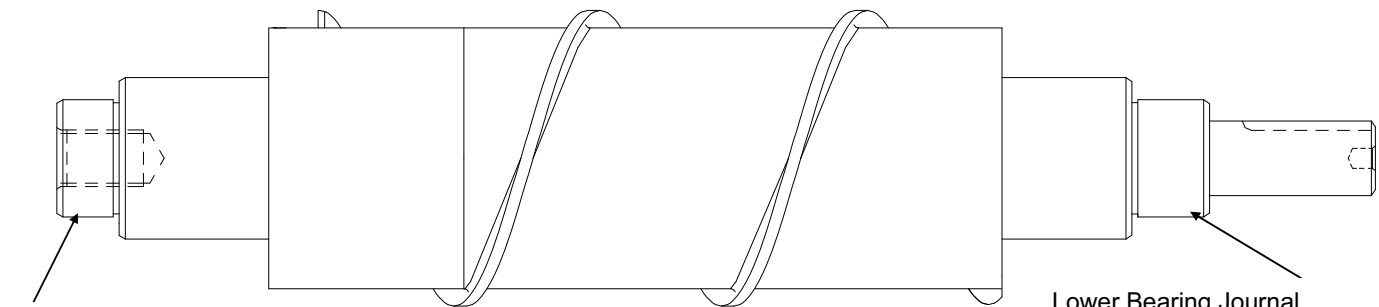
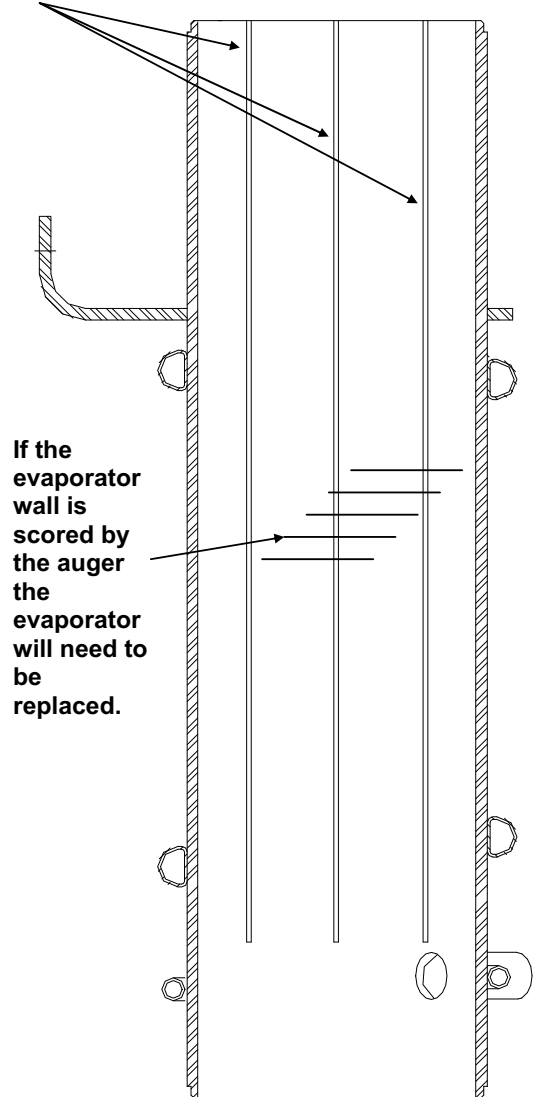

Upper Bearing Journal

Lower Bearing Journal

Damaged or worn evaporator components will cause high auger motor amp draw and may cause the evaporator to lock up.

Bearings, Water Seal and O-Rings

There is a bearing at the top and bottom of the auger shaft to allow the auger to rotate freely with a minimum amount of friction. The lower bearing is a sealed ball bearing and the upper bearing is a tapered roller bearing.

Tap the upper race out of the bearing housing.

The bearings can be inspected once removed from the machine by turning the bearing by hand. If the bearing does not turn smoothly, it should be replaced. Visually check the tapered roller bearing, if it is pitted, corroded or shows signs of wear, it must be replaced.

Upper Bearing and Race

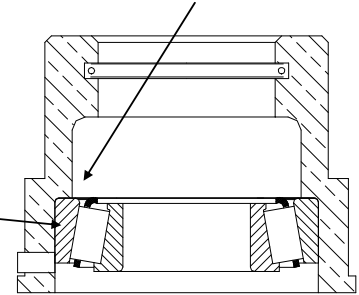

To remove the upper bearing race from the upper housing, turn the housing over and carefully tap the race out of the housing using a punch and hammer.

Tap out the lower bearing and water seal

To remove the lower bearing and water seal, turn over and support the housing assembly by the flange on the housing, carefully tap on the bearing with a punch and hammer until the water seal and bearing are removed from the housing.

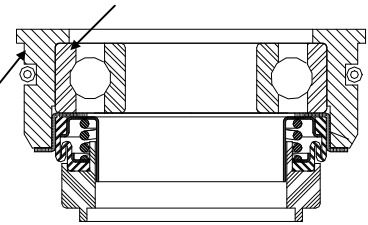

Support housing on housing flange

Housings Shown Inverted

Remove the O-Rings and clean the upper and lower bearing housings.

Install the new upper bearing race and lower bearing in their respective housings with a bearing press or a bearing driver. **Do not use a hammer directly in the bearing or bearing race.** Install new O-Rings in the upper and lower housings; lightly lubricate the O-Rings with white food grade grease. Lubricate the upper bearing and bearing race

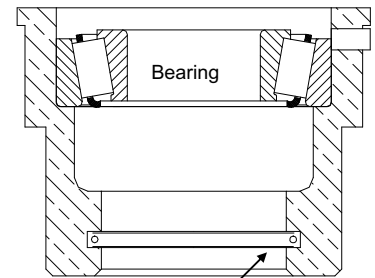

Install the lower water seal in the bearing housing by first applying a thin bead of silicone around the water seal flange circumference. This will prevent water from leaking between the housing and metal portion of the seal.

Upper O-Ring

Press the water seal into the housing with a bearing press and a short piece of PVC pipe.

← I.D. of pipe to match O.D. of water seal flange →

Place the pipe over the seal so that the pipe is in contact with the flange portion of the seal. Use a 2-3/4 I.D. pipe for 3 inch seals and a 1-3/4 I.D. pipe for the 2-1/2 inch seals. Insure that the pipe is cut off square. Use extreme caution to prevent damage to the seal. Remove any excess silicone from the flange.

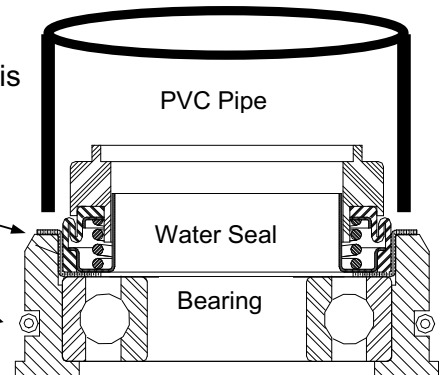

Apply a small bead of silicone to the seal flange circumference

Lower O-Ring

Flake Ice Machines

Drive System

Seal Face Installation

Lightly lubricate the rubber portion of the seal face and apply a small amount of silicone sealant to the metal part of the seal face (rubber side) that seats against the auger. Install the seal face on the auger.

Caution: Do not scratch or damage the seal face.

Evaporator Reassembly

Lubricate the upper O-Ring with food grade white grease and attach the upper housing to the auger. Pack the tapered roller bearing with Chevron Oil FM Grease EP NLGI 0 or equivalent. Fill the cavity below the bearing with grease. Install the bearing over the bearing journal, install the washer and bolt, tighten to 40 ft/lbs.

Lightly lubricate the O-Ring on the lower housing and install the complete lower housing into the evaporator by applying even pressure upward. It may be necessary to tap the housing with a rubber mallet or with a hammer and hard wooden block. Install and tighten the lower evaporator nut. Install and tighten the lower nut setscrews.

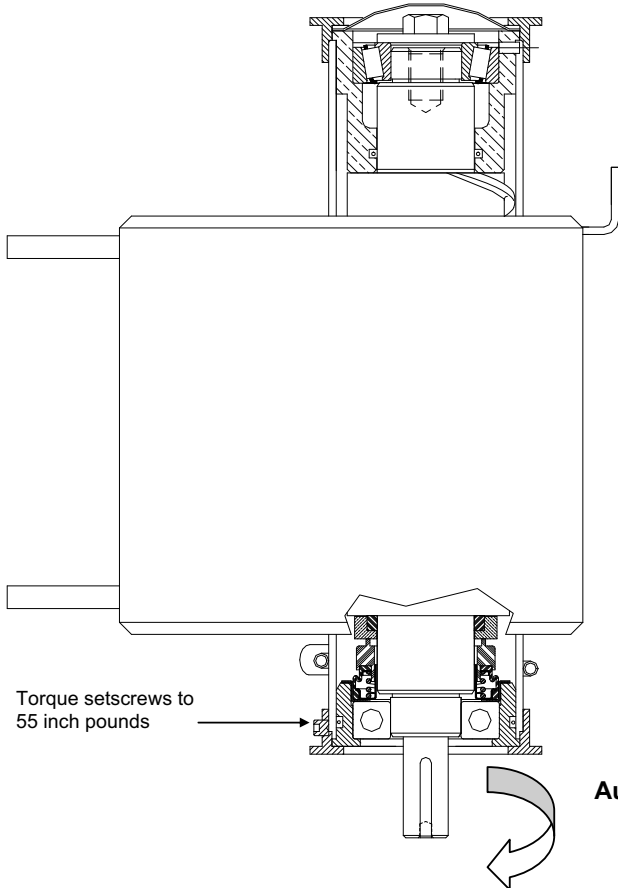
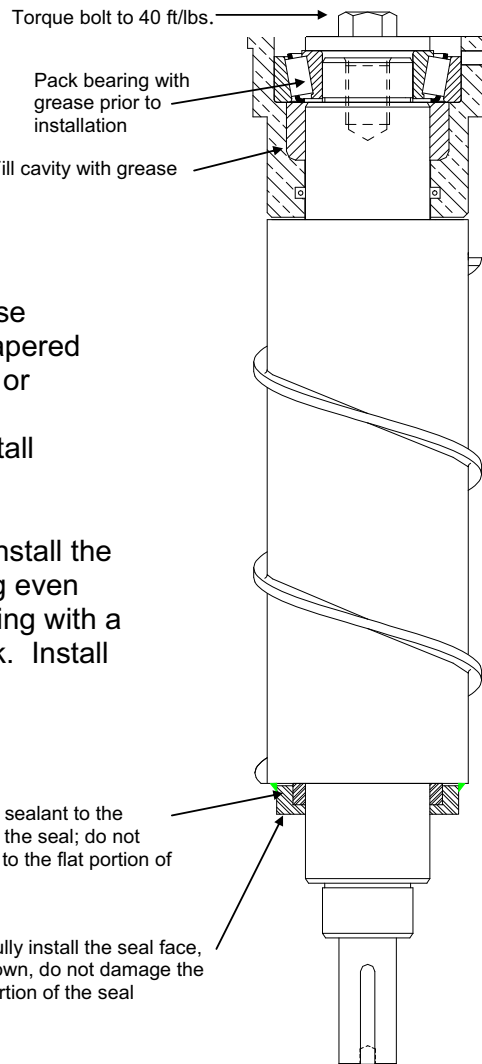

Carefully install the auger and upper housing assembly into the evaporator barrel, taking care not to scrape the evaporator walls. Push downward on the housing until the bearing housing is seated against the evaporator barrel. A rubber mallet may be needed to tap the housing into place. Install the grease cap and tighten the upper evaporator nut.

Reverse the first 6 steps in the Evaporator Disassembly Section.

Auger should turn freely by hand

Exploded View of the Evaporator

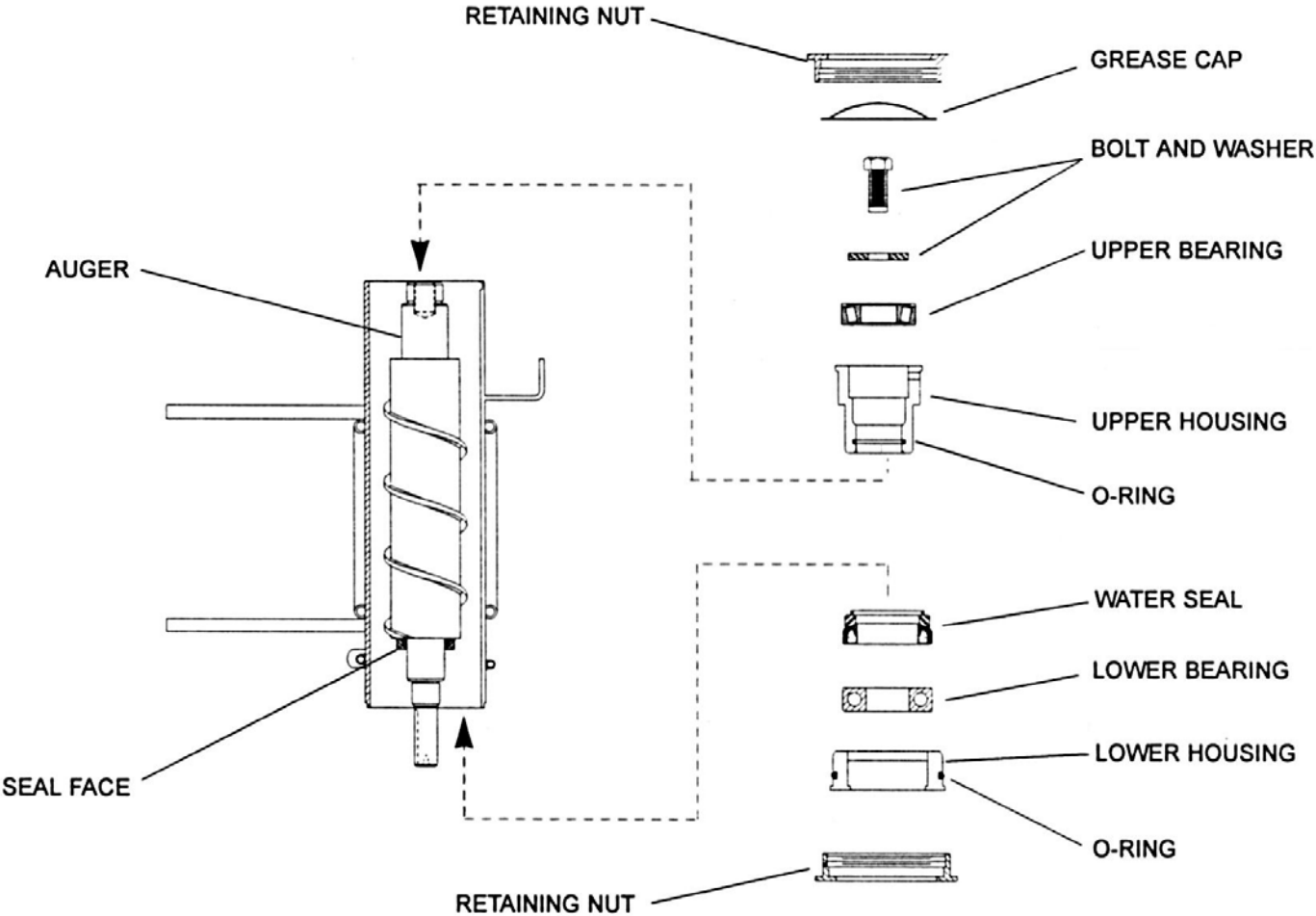

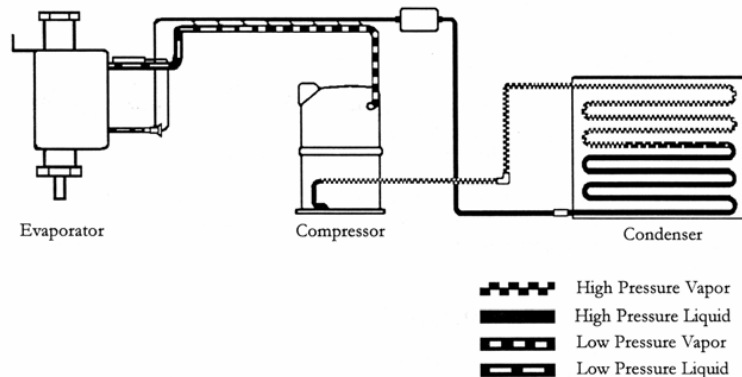

Refrigeration System and Components

Before diagnosing the refrigeration system, it is important that the refrigerant charge be correct. Whenever the refrigeration system has been opened, the filter-drier must be replaced and the proper refrigerant charge must be weighed in or measured. See refrigerant charge information on Page A5.

Refrigerant is circulated throughout the refrigeration system by a hermetic compressor. Refrigerant, in its vapor state is circulated from the compressor to the condenser. Heat is removed from the refrigerant. Heat is removed from the refrigerant either by forced air movement through the condenser or by a heat exchanger (water cooled condenser) that transfers heat from the refrigerant to the water. The refrigerant changes to a liquid when cooled.

The refrigerant in a liquid state passes through a filter drier. The filter drier traps moisture and foreign particles from the system.

Important! The filter drier must be replaced whenever the refrigeration system is opened or if the refrigerant charge is lost.

Compressor

The compressor runs during the entire ice making cycle. If the valves in the compressor are damaged, the compressor will be unable to pump refrigerant efficiently. Damaged valves may be the symptom of another problem in the refrigeration system, such as liquid returning to the compressor or high head pressure. Whenever a compressor is replaced, it is important that the refrigerant charge be weighed in or measured and the system checked for proper operation to prevent a repeat failure.

An inefficient compressor will usually have a higher than normal suction pressure and a lower than normal head pressure. Production will be slow and ice will be wetter than normal. Check the compressor amperage draw (On Machine Data Plate) after the compressor has been running for five minutes. If the compressor amp draw is less than 70% of the rated load amp, the compressor may be inefficient. These symptoms may also be caused by other problems. Therefore, it is important to use the troubleshooting trees when diagnosing a problem. See Electrical System for more information on the compressor and compressor start components.

Refrigerant Pressures

The operating pressures for models utilizing the **Alco thermostatic expansion valve** are listed below. Note that the suction pressure varies with the water and air temperature.

The discharge pressure on water cooled models should be adjusted to 250 PSI. See Water Regulating Valve on Page F6. The discharge pressure on air cooled units will vary with ambient conditions. The discharge pressure on remote models should not drop below 240 PSI. See Mixing Valve later in this section.

ALCO Manufactured Expansion Valve

Model Number	Air Temp °F	Water Temp °F	Suction Pressure PSIG	Discharge Pressure PSIG	
				192 LAC	240 LAC
EMF800A	90°F	70°F	48	293	
	70°F	50°F	42	233	
	50°F	40°F	37	180	
	110°F	100°F	57	373	
EMF800W	90°F	70°F	40	250	
	70°F	50°F	40	250	
	50°F	40°F	38	250	
	110°F	100°F	47	250	
EMF1106A	90°F	70°F	41	293	
	70°F	50°F	34	225	
	50°F	40°F	29	177	
	110°F	100°F	45	366	
EMF1106R	90°F	70°F	41	261	268
	70°F	50°F	36	209	257
	-20°F/50°F	40°F	33	192	240
	120°F/110°F	100°F	50	364	367
EMF1106W	90°F	70°F	37	250	
	70°F	50°F	35	250	
	50°F	40°F	24	250	
	110°F	100°F	42	250	
EMF2306A	90°F	70°F	41	316	
	70°F	50°F	35	247	
	50°F	40°F	32	211	
	110°F	100°F	47	396	

Refrigerant Pressures (Continued)

The operating pressures for models utilizing the **Alco** thermostatic expansion valve are listed below.

Model Number	ALCO Manufactured Expansion Valve				
	Air Temp °F	Water Temp °F	Suction Pressure PSIG	Discharge Pressure PSIG	
				192 LAC	240 LAC
EMF2306R	90°F	70°F	40	265	266
	70°F	50°F	35	217	260
	-20°F/50°F	40°F	33	200	263
	120°F/110°F	100°F	45	365	355
EMF2306W	90°F	70°F	38	250	
	70°F	50°F	37	250	
	50°F	40°F	36	250	
	110°F	100°F	42	250	
EMF405A	90°F	70°F	56	274	
	70°F	50°F	53	215	
	50°F	40°F	36	158	
	110°F	100°F	61	352	
EMF450A	90°F	70°F	56	290	
	70°F	50°F	52	222	
	50°F	40°F	51	131	
	110°F	100°F	57	374	
EMF450W	90°F	70°F	50	250	
	70°F	50°F	48	250	
	50°F	40°F	46	250	
	110°F	100°F	54	250	

Refrigerant Pressures

The operating pressures for models utilizing the **Alco thermostatic expansion valve** are listed below. Note that the suction pressure varies with the water and air temperature.

The discharge pressure on water cooled models should be adjusted to 250 PSI. See Water Regulating Valve on Page F6. The discharge pressure on air cooled units will vary with ambient conditions. The discharge pressure on remote models should not drop below 240 PSI. See Mixing Valve later in this section.

ALCO Manufactured Expansion Valve

Model Number	Air Temp °F	Water Temp °F	Suction Pressure PSIG	Discharge Pressure PSIG	
				192 LAC	240 LAC
EMF800A	90°F	70°F	48	293	
	70°F	50°F	42	233	
	50°F	40°F	37	180	
	110°F	100°F	57	373	
EMF800W	90°F	70°F	40	250	
	70°F	50°F	40	250	
	50°F	40°F	38	250	
	110°F	100°F	47	250	
EMF1106A	90°F	70°F	41	293	
	70°F	50°F	34	225	
	50°F	40°F	29	177	
	110°F	100°F	45	366	
EMF1106R	90°F	70°F	41	261	268
	70°F	50°F	36	209	257
	-20°F/50°F	40°F	33	192	240
	120°F/110°F	100°F	50	364	367
EMF1106W	90°F	70°F	37	250	
	70°F	50°F	35	250	
	50°F	40°F	24	250	
	110°F	100°F	42	250	
EMF2306A	90°F	70°F	41	316	
	70°F	50°F	35	247	
	50°F	40°F	32	211	
	110°F	100°F	47	396	

Refrigerant Pressures (Continued)

The operating pressures for models utilizing the **Alco** thermostatic expansion valve are listed below.

Model Number	ALCO Manufactured Expansion Valve		Suction Pressure PSIG	Discharge Pressure PSIG	
	Air Temp °F	Water Temp °F		192 LAC	240 LAC
EMF2306R	90°F	70°F	40	265	266
	70°F	50°F	35	217	260
	-20°F/50°F	40°F	33	200	263
	120°F/110°F	100°F	45	365	355
EMF2306W	90°F	70°F	38	250	
	70°F	50°F	37	250	
	50°F	40°F	36	250	
	110°F	100°F	42	250	
EMF405A	90°F	70°F	56	274	
	70°F	50°F	53	215	
	50°F	40°F	36	158	
	110°F	100°F	61	352	
EMF450A	90°F	70°F	56	290	
	70°F	50°F	52	222	
	50°F	40°F	51	131	
	110°F	100°F	57	374	
EMF450W	90°F	70°F	50	250	
	70°F	50°F	48	250	
	50°F	40°F	46	250	
	110°F	100°F	54	250	

To properly cool the condenser, there must be adequate airflow around the machine. The ambient air temperature should not exceed 100°F (38°C). See Installation Guideline on Page A6. The condenser coil and fan blades must be kept clean. The condenser can be cleaned with compressed air or by using a brush.

If a brush is used, brush in the direction of the fins taking care not to bend or distort the condenser fins. If the condenser fins are bent, this will also restrict the airflow through the condenser and the fins will need to be straightened with a fin comb.

Water Cooled Condenser

If the machine has been installed properly, the water flow through the condenser will be opposite the refrigerant flow. For proper water flow, the water for the condenser must be piped through the water valve first. The water condenser must have a minimum of 20 PSI (1.4 Bar) of flowing water pressure to the condenser. The water temperature to the condenser must not exceed 100°F (38°C). A water regulating valve is used to control to flow of water to the condenser. In areas that have poor water quality, the condenser may eventually become coated with mineral deposits. This will decrease the efficiency of the condenser resulting in high head pressure and high water usage. Water cooled condensers replaced because of failure due to excessive mineral build up will not be covered under warranty.

Water Regulating Valve

The water regulating valve controls the head pressure by regulating the amount of water flow through the condenser. The bellows of the water regulating valve are connected to the high side of the refrigeration system. As the discharge pressure rises, the bellows expand, increasing the water flow through the condenser. Adjusting the spring pressure screw at the top of the valve can change the rate of water flow.

The unit should be run for 10 minutes, then the valve should be adjusted as needed to maintain a refrigerant discharge pressure of 250 PSI (18.3 Bar). Water exiting the condenser should be between 100°F (38°C) and 110°F (43°C). When the machine is off, either on full bin or when the selector switch is in the off position, the regulating valve will close completely, stopping the flow of water through the condenser. If the water flow does not stop when the machine is not running, the valve should be replaced.

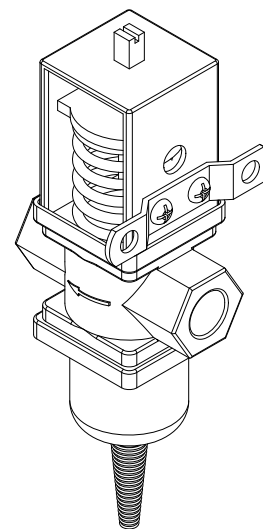

Air Cooled Condenser (Remote)

See Pages F10 or go to Page A10 for remote condenser installation.

High Pressure Safety

The high pressure safety control is a normally closed control. If the discharge pressure becomes too high, the high pressure safety control will open and shut the machine off. The high pressure safety control is an automatic reset type and will close and restart the machine when the pressure drops. The high pressure safety control is used on all water cooled and remote machines and some air cooled machines.

Refrigerant Pressures (Continued)

The operating pressures for models utilizing the **Sporlan thermostatic expansion valve** are listed below.

Model Number	SPORLAN Manufactured Expansion Valve				
	Air Temp °F	Water Temp °F	Suction Pressure PSIG	Discharge Pressure PSIG	
				192 LAC	240 LAC
EMF2306W	70°F	50°F	35	250	
	90°F	70°F	37	250	
EMF2306R	70°F	50°F	36	210	266
	90°F	70°F	41	275-280	260

Air Cooled Condenser (Except Remote)

Self Contained Models (EF Series)

The condenser and fan motor are located in front of the cabinet, behind the front louvered panel. Air is pulled through the left side panel and through the condenser and discharged through the front panel.



Modular Models (EMF Series) (Except 48 Inch Wide Units)

The condenser is located in the front of the machine. Air is pulled through the front louvered panel and through the air condenser by a fan motor. Air is discharged through the left and right hand side panels.

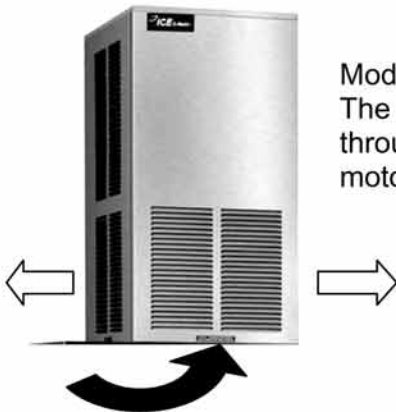

Modular Models (EMF Series 48 Inch Wide Units)

The condenser is located in the back of the cabinet. Air is pulled through the condenser by two (2) fans, and discharged through both louvered side panels.



Expansion Valve Diagnosis

Symptom	Problem	Remedy
<u>Single Evaporator Machine</u>		
1. Evaporator flooded but suction pressure too high. Compressor has been checked and appears to be good. Suction line at compressor may be colder than normal.	<ul style="list-style-type: none"> a. TXV sensing bulb uninsulated or not making good contact with suction line. b. TXV sensing bulb in wrong location. c. System overcharged. d. TXV stuck open. 	<ul style="list-style-type: none"> a. Clean suction line and clamp bulb securely. Insulate bulb. b. Relocate sensing bulb to top of suction line. c. Recover refrigerant and weigh in correct charge. d. Replace TXV.
2. Evaporator starved, no frost on line exiting evaporator. Suction pressure low.	<ul style="list-style-type: none"> a. Machine low on charge. b. TXV restricted or stuck closed. 	<ul style="list-style-type: none"> a. Recover refrigerant and weigh in correct charge. b. Replace TXV and filter-drier.
<u>Dual Evaporator Machine</u>		
1. Evaporator flooded but suction pressure too high. Compressor has been checked and appears to be good. Suction line at compressor may be colder than normal.	<ul style="list-style-type: none"> a. Machine low on charge. b. TXV restricted or stuck closed. c. System overcharged. d. An expansion valve stuck open. 	<ul style="list-style-type: none"> a. Recover refrigerant and weigh in proper charge. b. Replace TXV and filter-drier. c. Recover refrigerant and weigh in correct charge. d. Replace TXV.
2. One evaporator starved and one evaporator properly flooded, suction pressure lower than normal.	<ul style="list-style-type: none"> a. TXV restricted or sticking closed. 	<ul style="list-style-type: none"> a. Replace defective TXV

Production Check

Check ice production by allowing the machine to produce ice into a container for 15 minutes. If the machine has 2 evaporators, be sure to collect the ice from each evaporator separately so that production from each evaporator can be checked. Weigh the ice in each container and multiply the weight by 96. This will give you the approximate production in a 24 hour period.

Weight of ice produced in 15 minutes X 96 = production in 24 hours.

Note: Verify that the condenser is clean and the inlet water temperature and level is correct prior to performing a production check.

Evaporator

When water fills the evaporator, liquid refrigerant is circulated through the tubing wrapped around the evaporator. As the liquid refrigerant in the tubing vaporizes, it absorbs heat from the water, causing it to freeze. The evaporator should be completely flooded with refrigerant while the machine is making ice.

A flooded evaporator will build ice evenly in the evaporator. A starved evaporator will produce less ice and the ice will be wetter than normal. Most problems with ice quality or “freeze ups” are not related to a defective evaporator. Use the Troubleshooting Trees in Section C for additional help.

If the evaporator is flooded but the suction pressure is lower than normal and the ice production is slow, it is possible that the evaporator has a restriction. If the evaporator is flooded but the suction pressure is higher than normal and ice production is slow, it is possible that the evaporator has coil separation. Evaporator coil separation is the separation of the refrigerant tubing from the evaporator barrel. This is rare but may occur from time to time. Usually all of the following symptoms will be present.

- Higher than normal suction pressure.
- Cold or frosted compressor suction line.
- Slow ice production and/or wet ice.

If the coil is separated, the evaporator must be replaced. If the outlet of the evaporator is not frosted, the problem is not with coil separation. (Refer to the Troubleshooting Trees in Section C)

As liquid refrigerant leaves the evaporator, it changes to a low pressure vapor before returning to the compressor.

Important!

Liquid refrigerant must not return to the compressor or damage may result. Frost on the suction line at the inlet of the compressor indicates liquid may be returning to the compressor. Check for frost during the freeze cycle. If liquid refrigerant is returning to the compressor, the problem must be located and corrected.

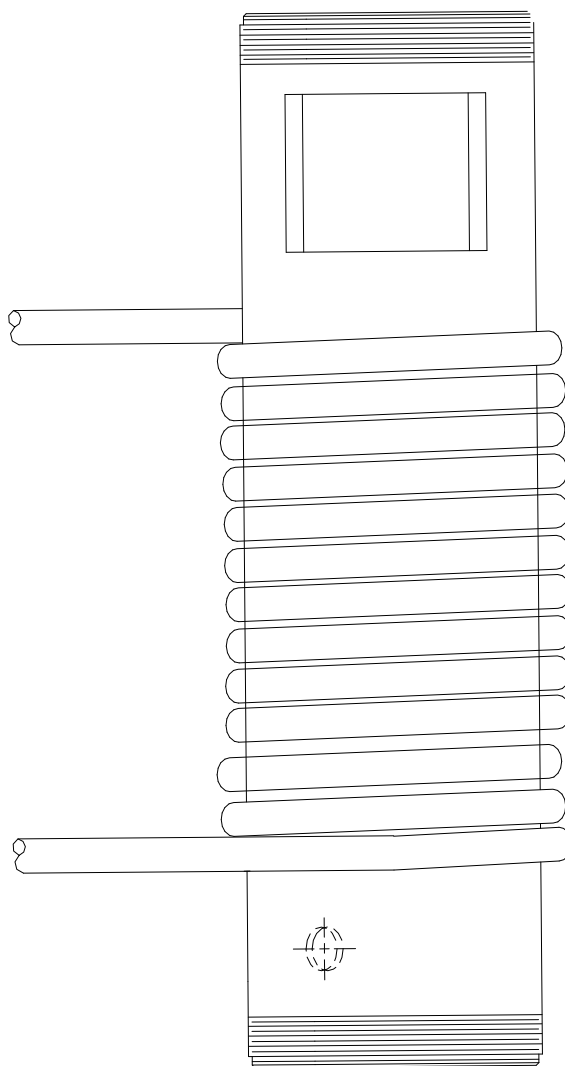

Remote System

Machines that use remote condensers have several components that are not used in self contained machines. A **mixing valve** controls the head pressure when the ambient temperature at the condenser drops below 70°F (21°C). When the bin fills with ice or is turned off at the selector switch, the machine will pump all the refrigerant into the receiver before shutting off.

Remote Condenser

For proper operation, the remote condenser must be installed properly. Improper installation will void the warranty. See remote guidelines on page A10. The location of the remote condenser should be such that the ambient air temperature does not exceed 120°F (48.9°C). If ambient temperature exceeds 120°F (48.9°C) ice production will decrease until the ambient temperature decreases.

If the airflow is restricted or the condenser is dirty, the head pressure will be excessively high, slow production will result and the compressor may overheat and eventually become damaged. The condenser coil and fan blades must be kept clean. The condenser can be cleaned with compressed air or by using a brush. If a brush is used, brush in the direction of the fins taking care not to bend the fins. If the condenser fins are bent, this will restrict the airflow through the condenser and the fins will need to be straightened with a fin comb. Problems related to a dirty condenser or poor airflow will not be covered under warranty. **Note:** The condenser fan motor runs continually, it will shut off when the icemaker shuts off.

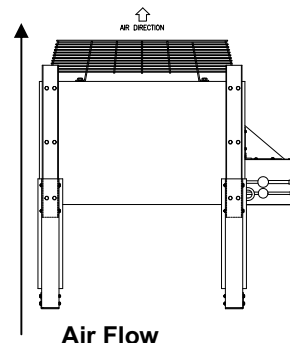

Mixing Valve (L.A.C., Headmaster)

When the temperature at the condenser is above 70°F (21°C), the refrigerant flow from the compressor is directed by the mixing valve through the condenser and into the receiver.

When the temperature at the condenser drops below 70°F (21°C), the pressure in the bellows of the mixing valve becomes greater than the pressure of the liquid refrigerant coming from the condenser. This change allows the valve to partially restrict the flow of refrigerant leaving the condenser and allows discharge gas to by-pass the condenser and flow directly into the receiver, mixing with the liquid refrigerant from the condenser. The amount of discharge gas that bypasses the condenser increases as the ambient temperature decreases. This action of the mixing valve allows the discharge pressure to be maintained at approximately 240 psi (16.5 bar) during low ambient conditions. If the refrigerant system is undercharged and the ambient temperature is below 70°F (21°C), the mixing valve will not work properly. The mixing valve will allow too much refrigerant to bypass the condenser.

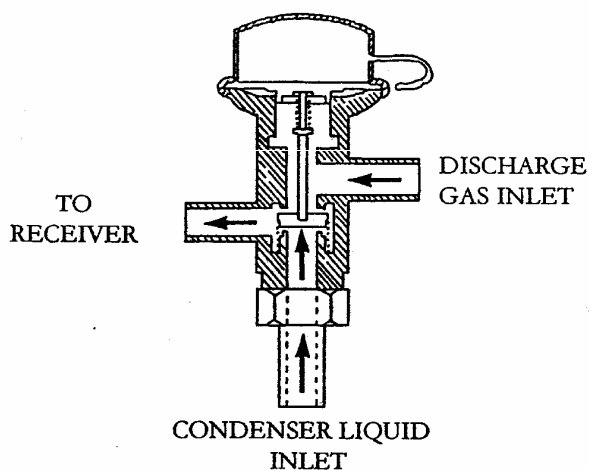

Mixing Valve Diagnosis:

Problem	Possible Cause	Remedy
1. Head pressure low, Line between valve and receiver cold. Ambient condenser temp. below 70°F (21°C)	a. Valve defective, not allowing discharge gas into receiver	a. Replace valve
2. Head pressure low, Line between valve and receiver hot.	a. System low on charge. b. Valve defective, not allowing liquid into receiver.	a. Leak check. Recover refrigerant and weigh in proper charge. b. Replace valve.
3. Head pressure low, Line returning from condenser is cool. Ambient condenser temperature is above 70°F (21°C)	a. Valve defective, not allowing refrigerant through condenser.	a. Replace valve.

Pump Down System (Remote Only)

The pump down system prevents liquid refrigerant from migrating to the evaporator and compressor during the off cycle and prevents the compressor from slugging or starting under an excessive load.

Liquid Line Solenoid

When a machine with a remote condenser shuts off, the liquid line solenoid valve, located at the outlet of the receiver, is de-energized causing the valve to close completely restricting the flow of refrigerant. The compressor will pump all of the refrigerant into the condenser and receiver.

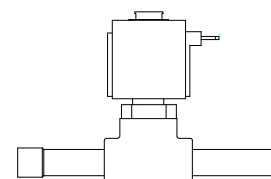

As the system pumps down, the pressure on the low side of the system drops. When the suction pressure drops to 19 psi (1.3 bar), the pump down control opens and shuts the machine off. See page G5 for pump down control operation. Liquid refrigerant is stored in the condenser and receiver while the machine is off. It is normal for the machine to pump down once or twice an hour as the pressures equalize.

When the machine comes back on (the bin switch closes or the selector switch placed to the ICE position), the liquid line solenoid valve opens and the refrigerant is released from the receiver. When the suction pressure rises to 45 psi (3.1 bar) the pump down control closes and the machine comes back on. If the machine will not pump down, the valve may not be closing all the way. A weak compressor will also prevent the machine from pumping down. Check for signs of a weak compressor before replacing the liquid line solenoid. Prior to replacing the valve, disassemble and check for obstructions that may not allow the valve to seat.

Flake Ice Machines

Refrigeration System

Receiver

If the system has a remote condenser, the refrigerant will enter a receiver before passing through the filter drier. The receiver holds reserve liquid refrigerant during the freeze cycle. The receiver also stores liquid refrigerant during the off cycle.

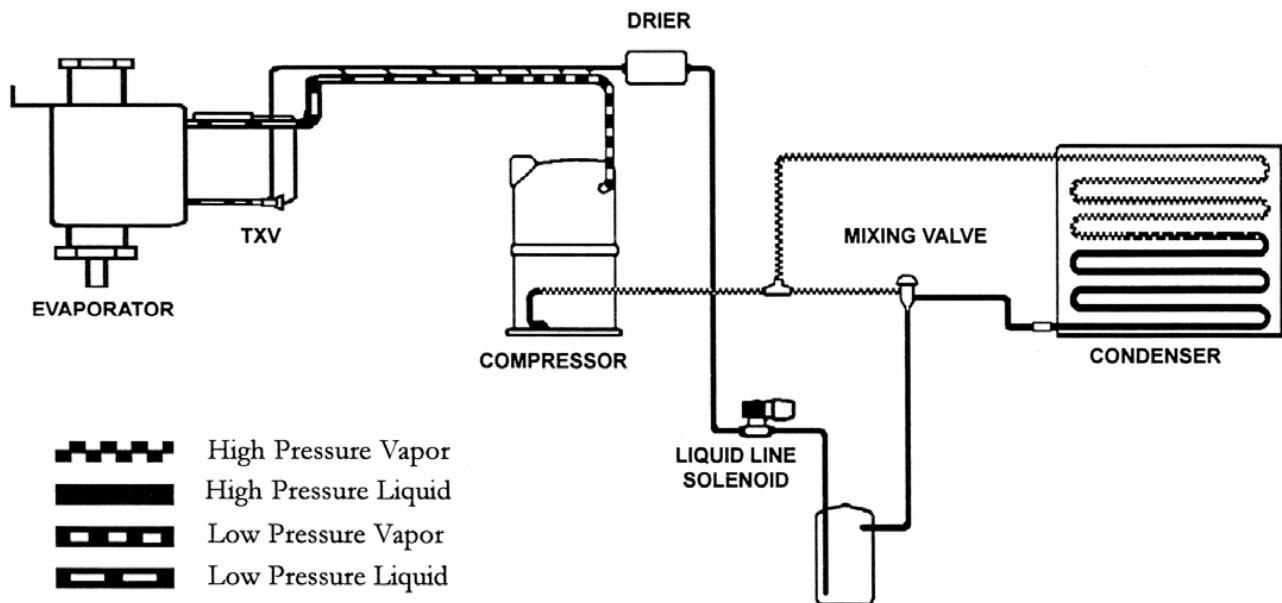
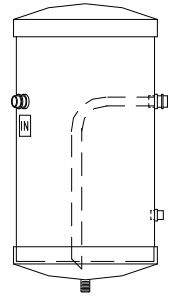

Refrigerant

Refrigerant in a high-pressure liquid form is fed to an expansion valve where the refrigerant is reduced to a low-pressure liquid. Under this low pressure, the liquid will absorb heat from the evaporator causing the liquid to change to a vapor. This vapor is drawn into the compressor where the temperature and pressure of the vapor are increased. The high temperature, high pressure vapor flows to the condenser where the heat is removed, causing the vapor to return to the liquid form, making the refrigerant ready to flow back to the evaporator to pick up more heat.

Most Ice-O-Matic ice machines use R134a or R404a refrigerant. Always check the serial number data plate for the proper type of refrigerant and the amount used in the machine you are servicing.

R404a and R134a are both HFC refrigerants, which result in no ozone depletion factor. R404a cylinders are orange in color, R134a cylinders are light blue in color.

Important: When discharging refrigerant from an icemaker, recover as much of the refrigerant as possible with a recovery device or some other means to prevent the refrigerant from entering the atmosphere.

Method of Charging Refrigerant

In order to achieve a properly charged refrigeration system, the system must be completely evacuated.

To achieve a complete evacuation you will need a service gauge manifold with properly maintained hoses, and a vacuum pump capable of pulling a 50-micron vacuum. This will require a two-stage pump.

Connect the service gauge manifold to the high and low side service ports and vacuum pump. Make sure the valves on the gauge manifold are closed, then start the pump.

Note: Do not use a refrigeration compressor as a vacuum pump. Compressors are able to pull only a 50,000-micron vacuum.

After the vacuum pump has been started, open the valves on the gauge manifold. This will allow the refrigeration system to start being evacuated.

If there has not been an excessive amount of moisture in the system, allow the vacuum pump to pull the system down to about 200 microns or 29.9 inches or less. Once this has been achieved, allow the vacuum pump to operate for another 30 minutes. Then close the valves on the gauge manifold and stop the vacuum pump. Then watch your gauges. A rise to 500 microns in three (3) minutes or less indicates a dry system under a good vacuum.

If your gauge registers a more rapid rise, the system either has moisture remaining or there is a leak in the system, requiring a check for the leak, and repair and another complete evacuation.

Note: Seal the ends of the gauge manifold hose and pull them into a deep vacuum to determine if the leak is not in the hoses. The gauge manifold should be able to hold the vacuum for three (3) minutes.

If the refrigeration system is extremely wet, use radiant heat to raise the temperature of the system. This action will cause the moisture to vaporize at less of a vacuum.

The use of two (2) valves, one between the vacuum pump and gauge manifold and the other between the refrigerant cylinder and the gauge manifold allows you to evacuate and charge the system without disconnecting any hoses. If the hoses were disconnected, air or moisture will have the opportunity to enter the hoses and then the system.

A properly charged icemaker is a service technician's greatest ally. Proper charging will allow any concern with the icemaker to be accurately diagnosed.

The refrigerant charge must be weighed into the icemaker either by using a charging scale or with a dial-a-charge.

The amount of proper refrigerant required for the icemaker is printed on the serial data plate attached to the icemaker and is listed on the following pages. Never vary the amounts from those listed.

Remote models with sixty (60) foot lineset runs will need an additional fifteen (15) ounces of refrigerant added.

In some cases the complete refrigerant charge may not enter the refrigeration system. In those instances, close the gauge manifold high side valve and disconnect the manifold from the high side port.

When the icemaker is completely charged, secure the caps to the service ports and check to make sure the ports are not leaking refrigerant.

Reference Tables on Page A5.

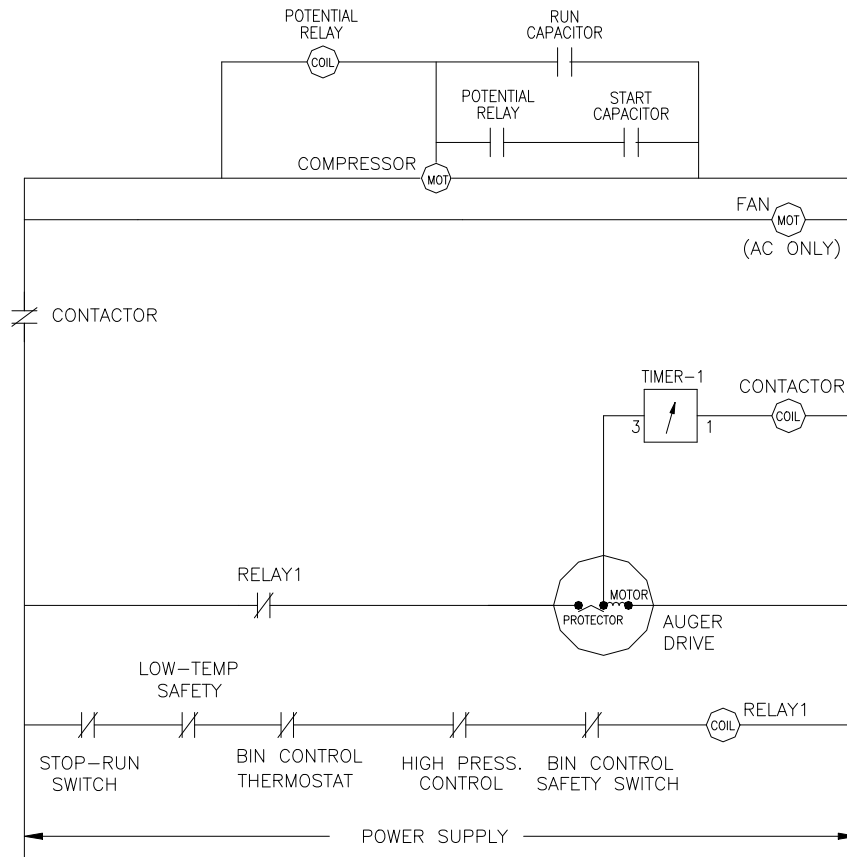

Control Circuit

All machines in this manual are controlled basically the same way.

Selector Switch

The selector switch is used to start the ice making cycle or to turn the machine off. The machine is put into operation by switching the selector switch to the ON position.

Contactor

When the selector switch is in the ICE position, the contactor coil is energized and pulls in the contactor contacts. This energizes the compressor start components, which starts the compressor.

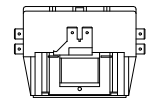

Compressor and Start Components

The compressor should run during the entire cycle. If the machine is in the ICE position but the compressor is not running, check the compressor contactor to see if it is engaged. If the contactor is not engaged, the problem is not with the compressor or the compressor start components. If the contactor is engaged and there is correct voltage through the contactor, there could be a problem with one of the starting components or the compressor. It is recommended that the compressor starting components be replaced when replacing a compressor.

Compressor Check**Disconnect power before servicing**

If the compressor uses an internal overload, be

certain that the compressor has cooled and the overload has reset before diagnosing the compressor. If the compressor is cool and is still not running, check the compressor motor windings by first removing the wires at the compressor terminals. With an ohmmeter, check for continuity between all three terminals, if an open circuit exists between any of the terminals, the compressor may need to be replaced. Check for continuity from each terminal to the compressor body, if continuity is found from any terminal to the compressor body, the compressor windings are shorted to ground and the compressor will need to be replaced. If the compressor appears to be good at this point, it is advisable to use a compressor analyzer to isolate the compressor from the start components while checking for a locked rotor. If an analyzer is not available, the compressor starting components must be checked.

If all starting components are good, check the amperage draw from the common terminal of the compressor, making sure proper voltage is supplied to the compressor and all wiring is properly connected. If the compressor does not start and there is excessive amperage draw, (see locked rotor amps on compressor tag) the compressor has a locked rotor and should be replaced.

Important: Compressors returned to the factory for warranty are tested and will not be covered under the warranty policy if they are not defective.

Overload (External)

If there is no amperage draw check the compressor overload. The compressor overload can be checked for continuity after removing it from the compressor and letting it cool to room temperature. If there is no continuity between the two terminals, replace the overload. If the overload is suspected of opening prematurely, it should be replaced with an overload, which is known to be good.

Capacitors

The start capacitor is an electrical storage device used to provide starting torque to the compressor. If a start capacitor is defective, the compressor will not start properly.

The run capacitor is an electrical storage device used to improve the running characteristics and efficiency of the compressor.

Before checking a capacitor, it should be discharged by shorting across the terminals. If a run or start capacitor is cracked, leaking or bulging it should be replaced. If a capacitor is suspected of being defective, it can easily be checked by replacing it with a capacitor of the correct size, which is known to be good. If the compressor starts and runs properly, replace the original capacitor. A capacitor tester can also be used.

Start Relay

The start relay breaks the electrical circuit to the start windings when the compressor motor speed increases. If the relay is defective, the compressor will not start or it may start but will run for a very short time.

A compressor relay can be checked by removing the relay and checking the relay contacts for damage and check for continuity across the closed relay points. Check the relay coil with an ohmmeter. If no continuity is read, replace the relay.

Flake Ice Machines

Electrical System

Safety Control

The low temperature safety control prevents the machine from operating without water in the evaporator or if the v-belt breaks. If the evaporator temperature drops below approximately 30°F (-1°C), the safety control will open and shut the machine off.

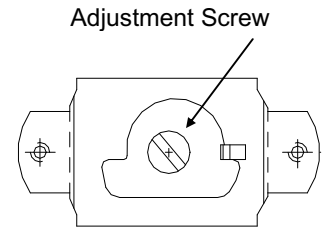

The safety control is located in the control box and the capillary tube is located in a thermal well attached to the bottom of the evaporator barrel just above the lower nut.

To check the safety control for proper operation, turn the water supply to the float off and allow the machine to operate. When the water in the float and feed tube has been depleted, the safety control should open, shutting the machine off within approximately 3 minutes. Once the water supply has been turned back on, the control should close and the machine should start within approximately 5 minutes.

The safety control can be adjusted by turning the adjusting screw clockwise to lower the cut-out temperature (colder) and counterclockwise to raise the cut-out temperature (warmer).

Bin Control

A primary thermostatic bin control and mechanical secondary bin switch in used to shut the machine off when the bin becomes full of ice.

Thermostatic Bin Control

The thermostatic bin control is located in the control box with the capillary tube housed in a thermal well located in the bin or down chute. When ice comes in contact with the thermal well, the contacts in the control open and the machine shuts down.

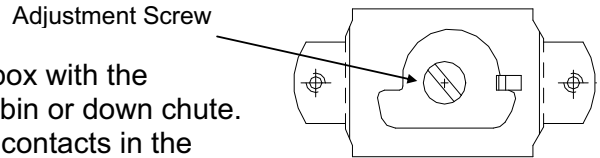

When ice is removed, the machine comes back on. Check the thermostatic bin control for proper adjustment with the machine running by covering approximately 6 inches (15CM) of the thermal well. The machine should shut off in approximately 3 minutes. Remove the ice once the machine shuts off and the machine should restart within approximately 5 minutes. The bin control can be adjusted by turning the adjusting screw clockwise to lower the cut-out temperature (colder) and counterclockwise to raise the cut-out temperature (warmer).

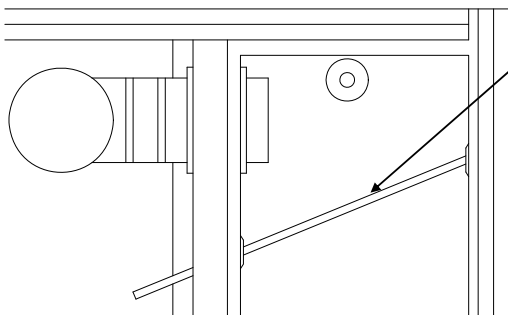

EMF Series Thermal Well

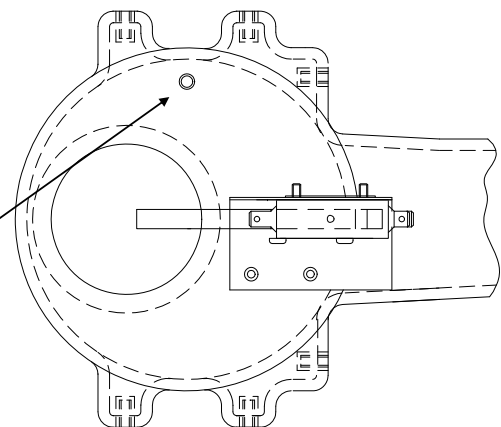

Mechanical Bin Control

The mechanical bin control is located in the top panel of the ice bin on the EF Series and on the top of the down chute on the EMF Series. When ice fills the down chute on the EMF Series units, or ice fills the bin on EF Series units a rubber diaphragm pushes up against a switch.

To check the bin switch, push up on the diaphragm or switch arm raising it approximately 1/8 inch. This movement should actuate (open) the switch. The switch should close when returned to the normal position. The switch can be adjusted by loosening the adjusting screws and moving it to the proper position.

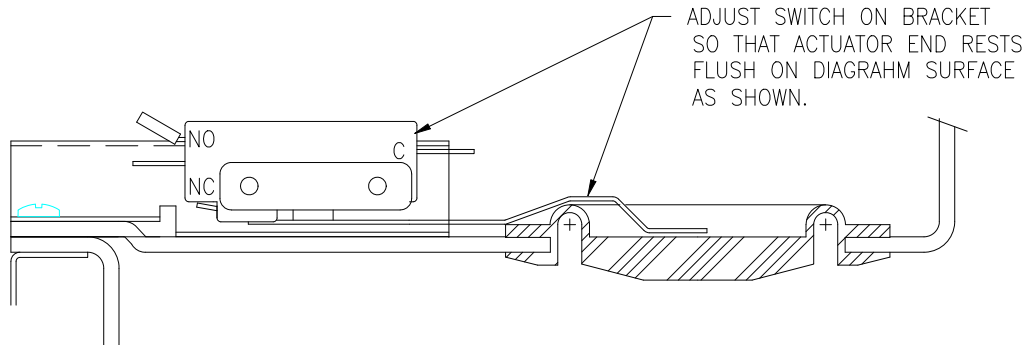

Important! The secondary bin switch should only be utilized as a safety. If the machine is shutting off on the secondary control, the primary control should be adjusted.

Auger Motor Relay

The auger motor relay is used on modular models to energize the auger motor, preventing excessive current through the bin control. When power is supplied to the coil of the relay, the normally open contacts close, energizing the auger motor.

Auger Motor

The auger drive motor is used to turn the gear reducer via a V-Belt. The auger motor should turn counter clockwise when facing the pulley end of the motor.

The auger motor uses an internal overload protector, which opens if the motor is under excessive load. If the overload protector opens, the entire machine will shut off and will restart when the overload cools and resets. Problems with the drive system such as a dirty evaporator or bad bearings are usually the cause of the overload protector tripping. This can be checked by reading the auger motor amp draw. A fluctuation of more than 4/10 of an amp indicates there may be a problem in the drive system. See the Troubleshooting Trees on Page C9. **Note:** When replacing an auger motor, make sure the new motor is wired properly.

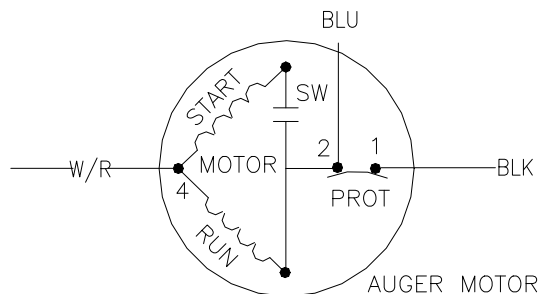

Compressor Delay

When the machine starts, the compressor delay timer is energized. Once the timer counts out, the contactor is energized and the compressor starts.

The compressor delay timer will keep the compressor off for approximately 5 minutes when the machine restarts for any reason. This will reduce the load on the auger drive system. On remote units, the compressor delay timer energizes the liquid line solenoid.

Note: The compressor delay timer is only utilized on the EMF1106/5 and EMF2306/5 units.

Pump Down System (Remote Only)

If a remote machine is shut down by the selector switch or bin control, the liquid line solenoid valve is de-energized allowing the valve to close. This blocks the flow of refrigerant causing all the refrigerant to be pumped into the receiver and condenser. This is done to prevent liquid refrigerant from migrating into the compressor during the off cycle, which could damage the compressor on start-up. Also see Pump Down System in the Refrigeration Section on page F11. As the refrigerant is pumped into the receiver, the suction pressure begins to drop. Once the suction pressure reaches approximately 19 psi (1.7 bar) the pump down control contacts open, which will de-energize the compressor contactor.

Pump Down Control

The pump down control is a low pressure control that shuts the machine off when the suction pressure drops during the pump down phase. The control is factory set to open at 19 psi (1.7 bar) and close at 45 psi (3.1 bar). The pump down control does not normally need to be adjusted, however an adjustment may be made by turning the adjustment screw,

Flake Ice Machines

Electrical System

EF250/255/405
EF450A/W

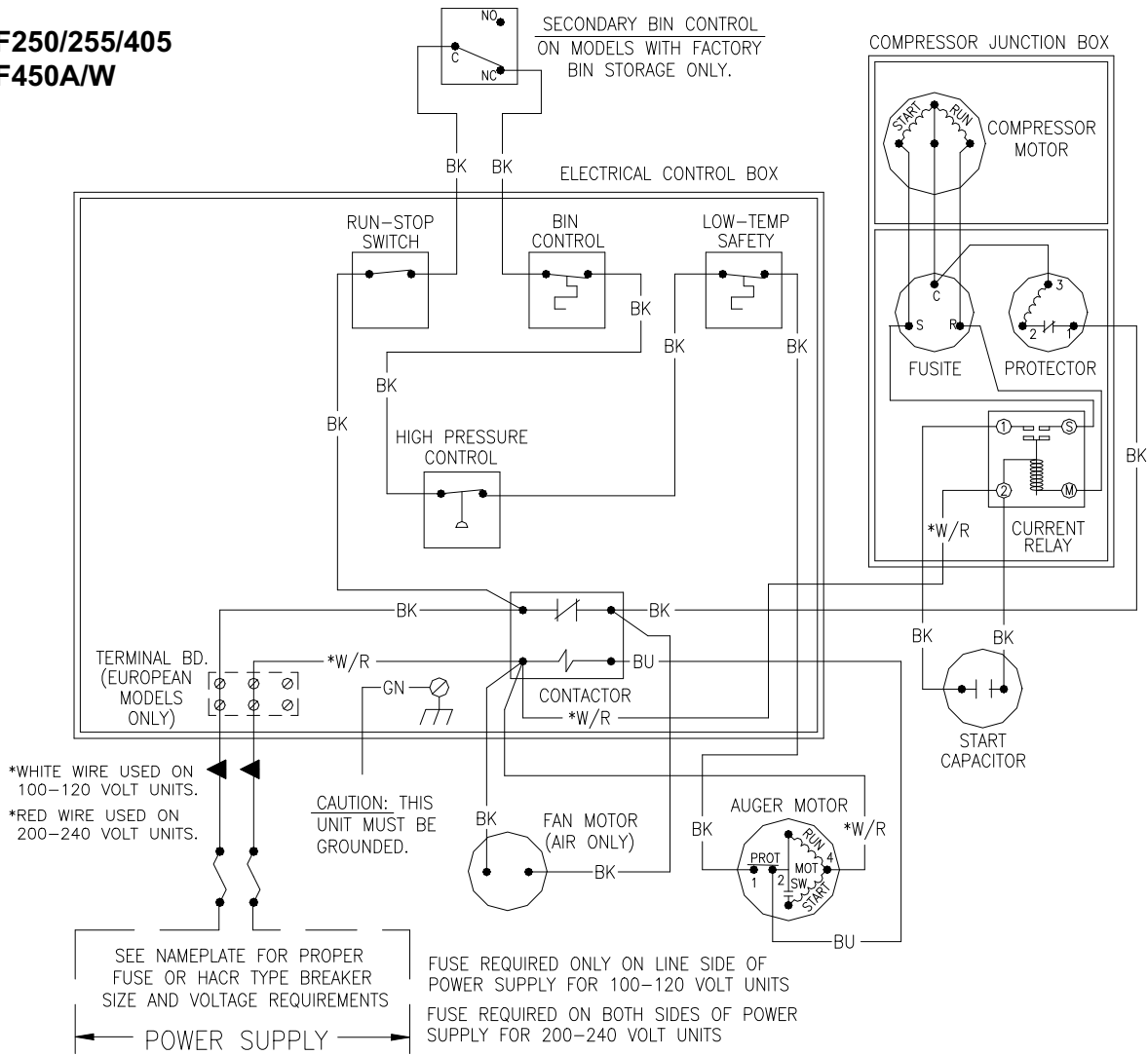

CONTROLS SHOWN IN NORMAL
ICE MAKING MODE

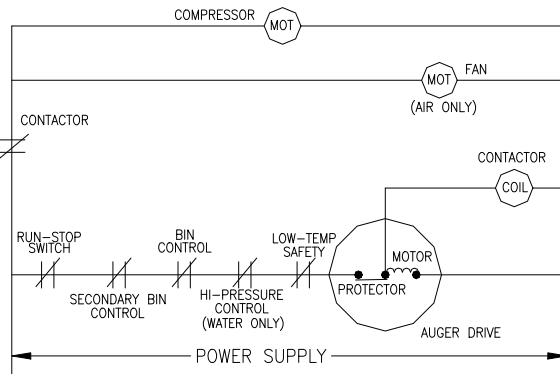

Flake Ice Machines

Electrical System

EF800A/W

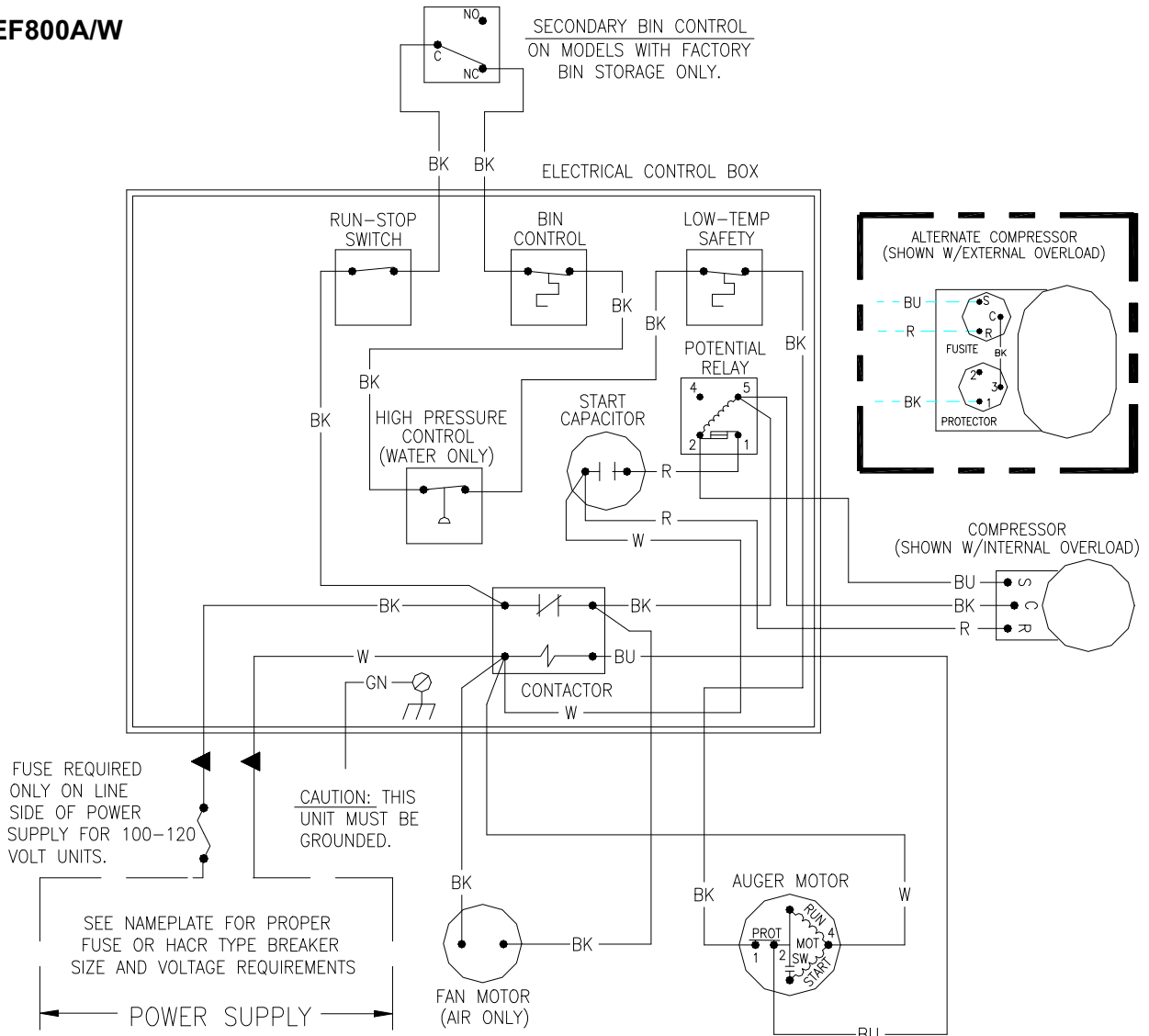

CONTROLS SHOWN IN
NORMAL ICE MAKING MODE

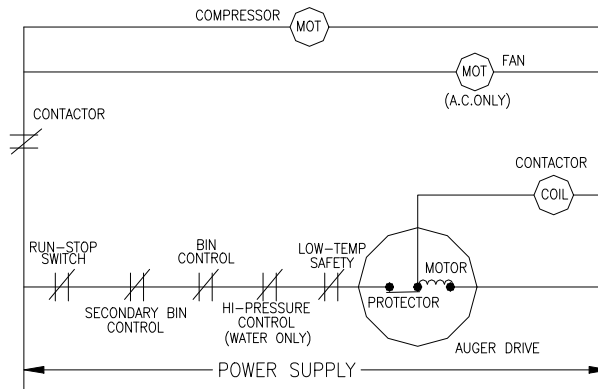

Flake Ice Machines

Electrical System

EMF450/405A/W

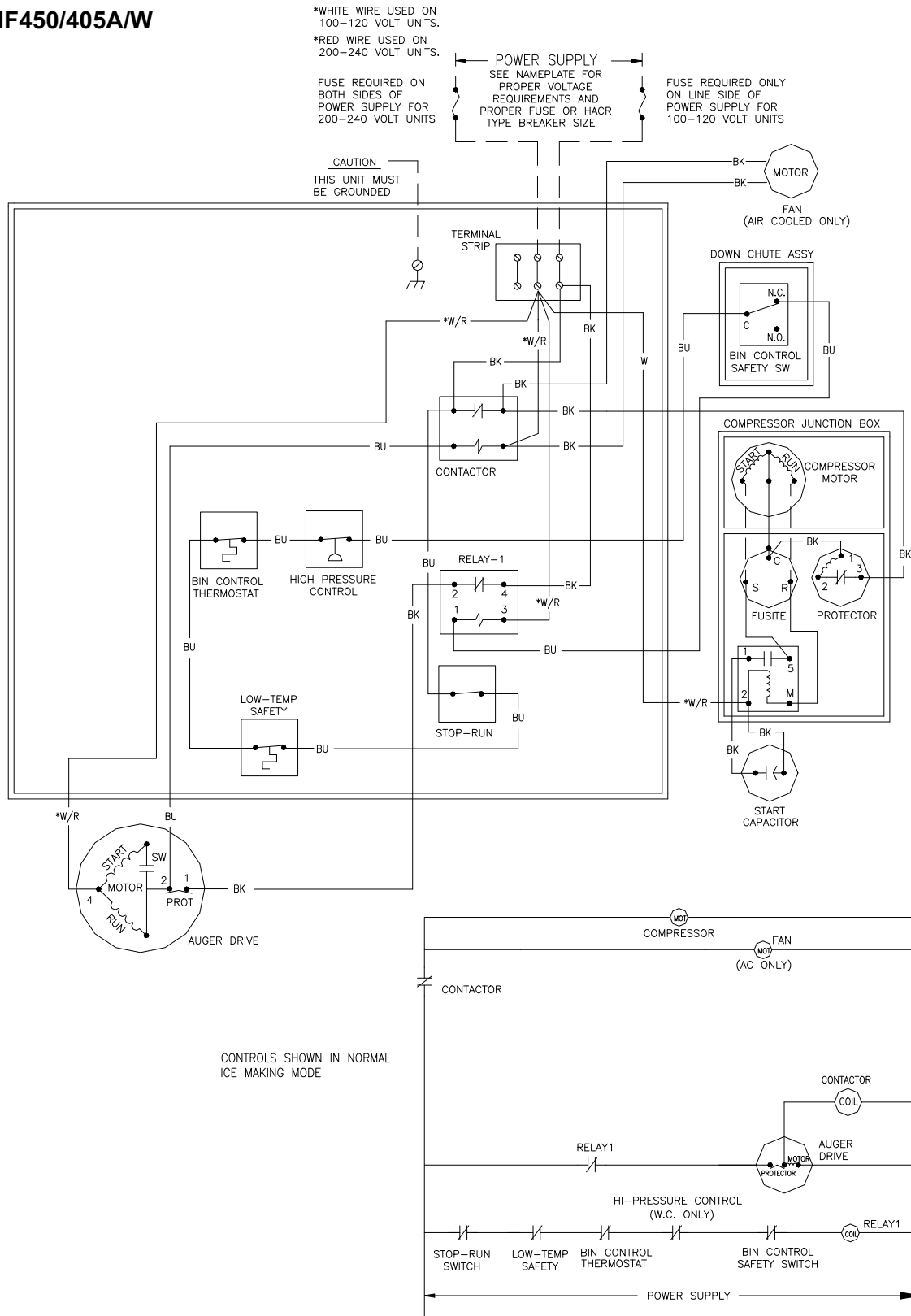

Flake Ice Machines

Electrical System

EMF800A/W

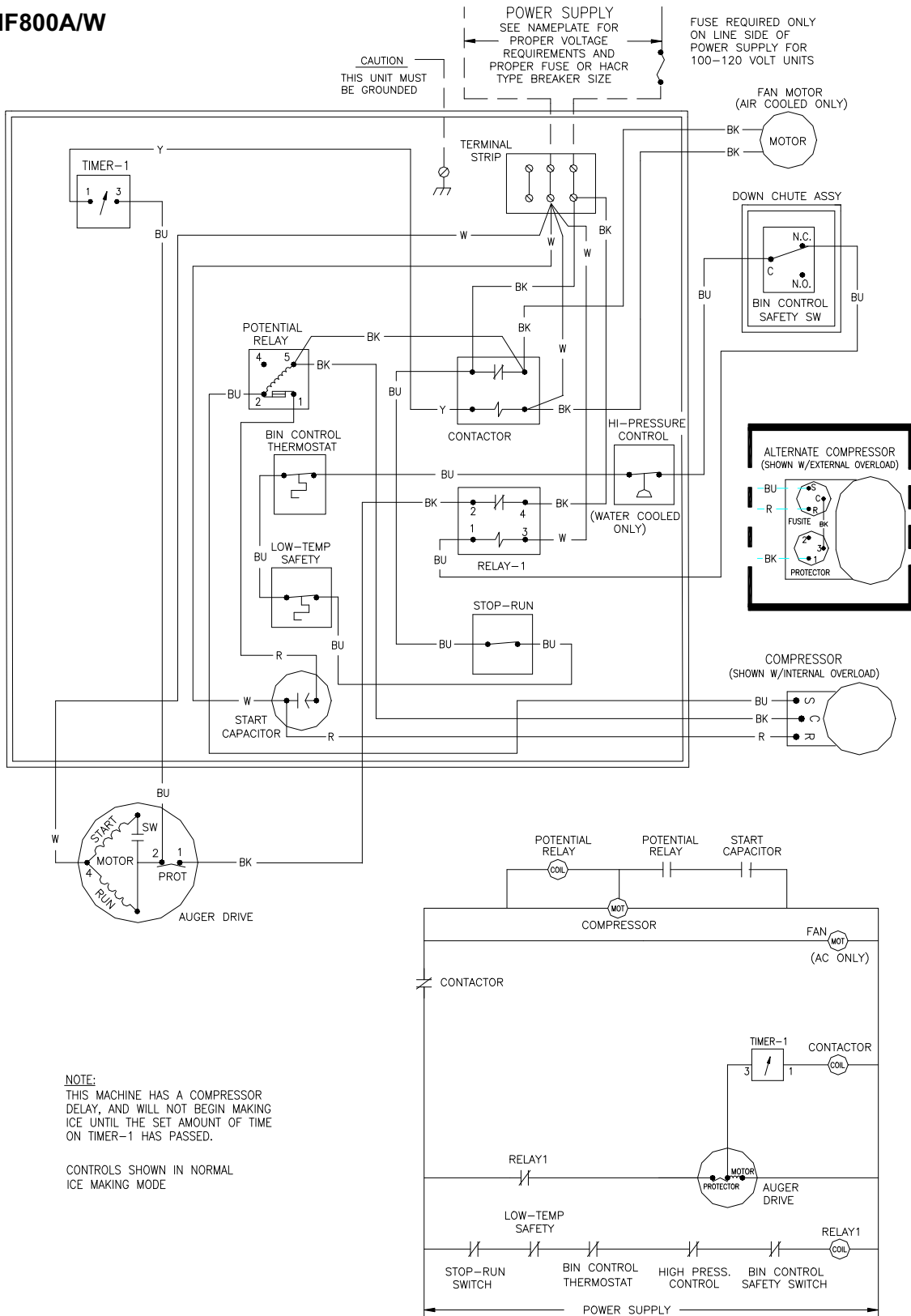

Flake Ice Machines

Electrical System

EMF705/1005/1006A/W

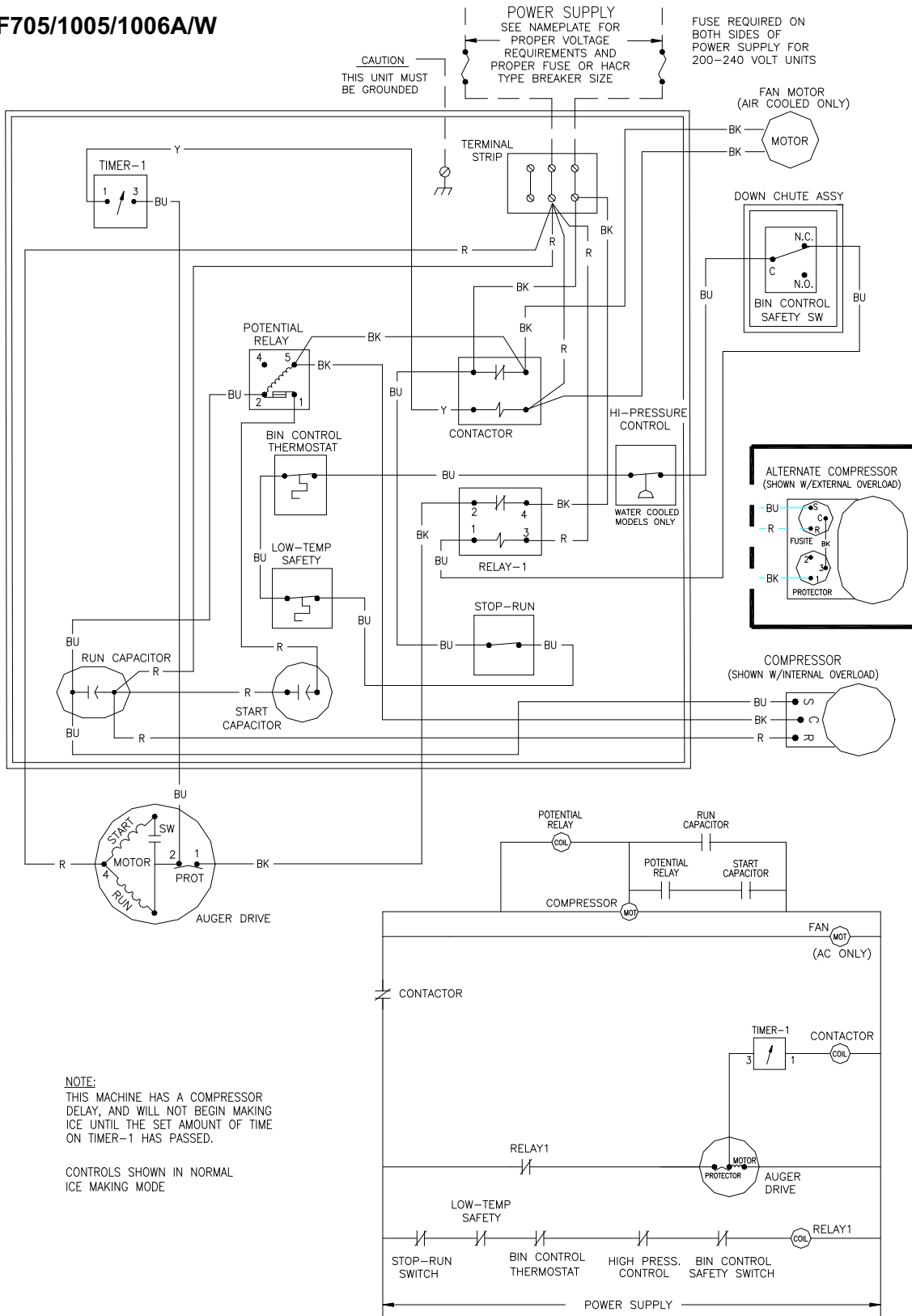

Flake Ice Machines

Electrical System

EMF1106R

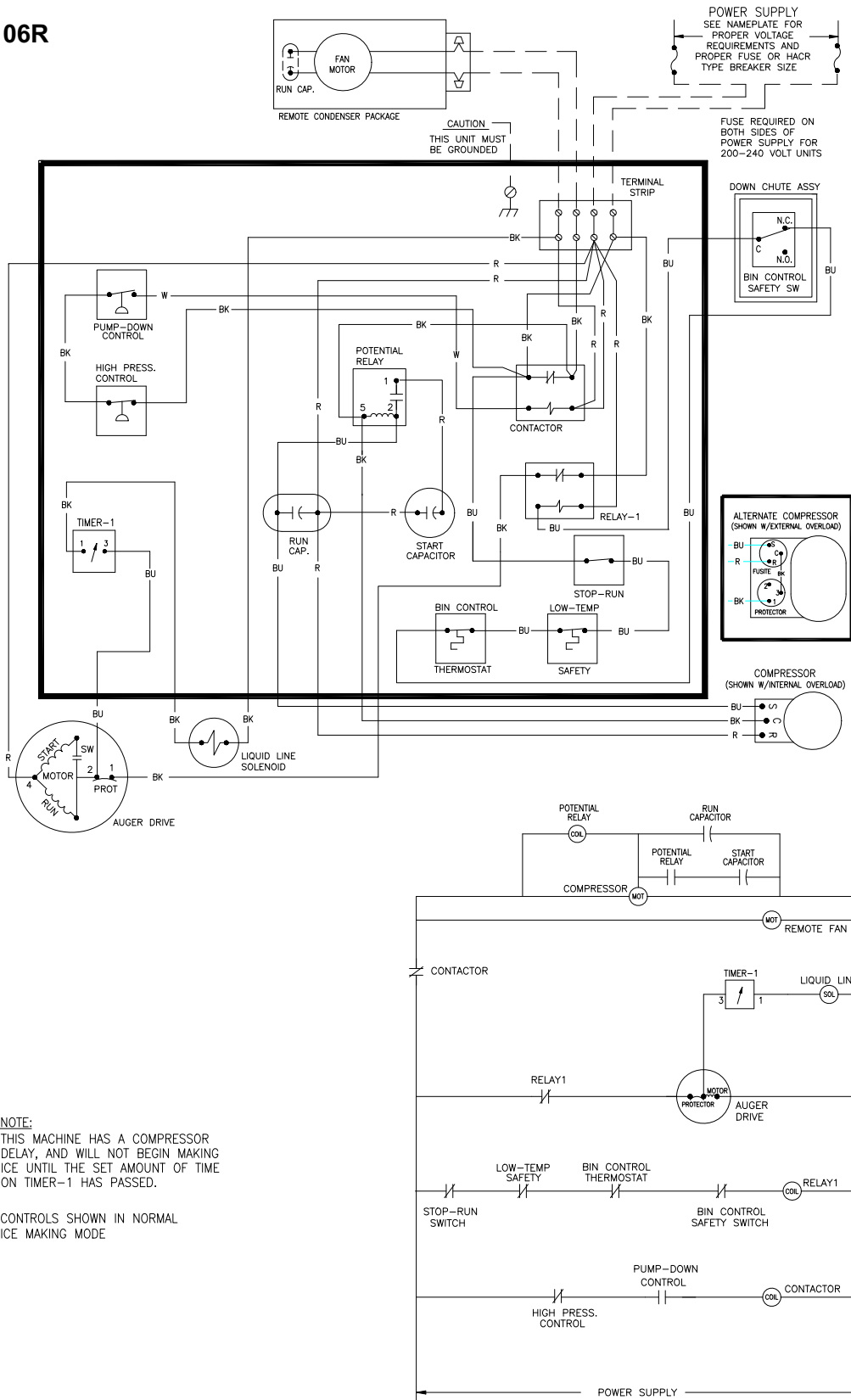

Flake Ice Machines

Electrical System

EMF2306A/W

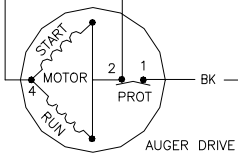
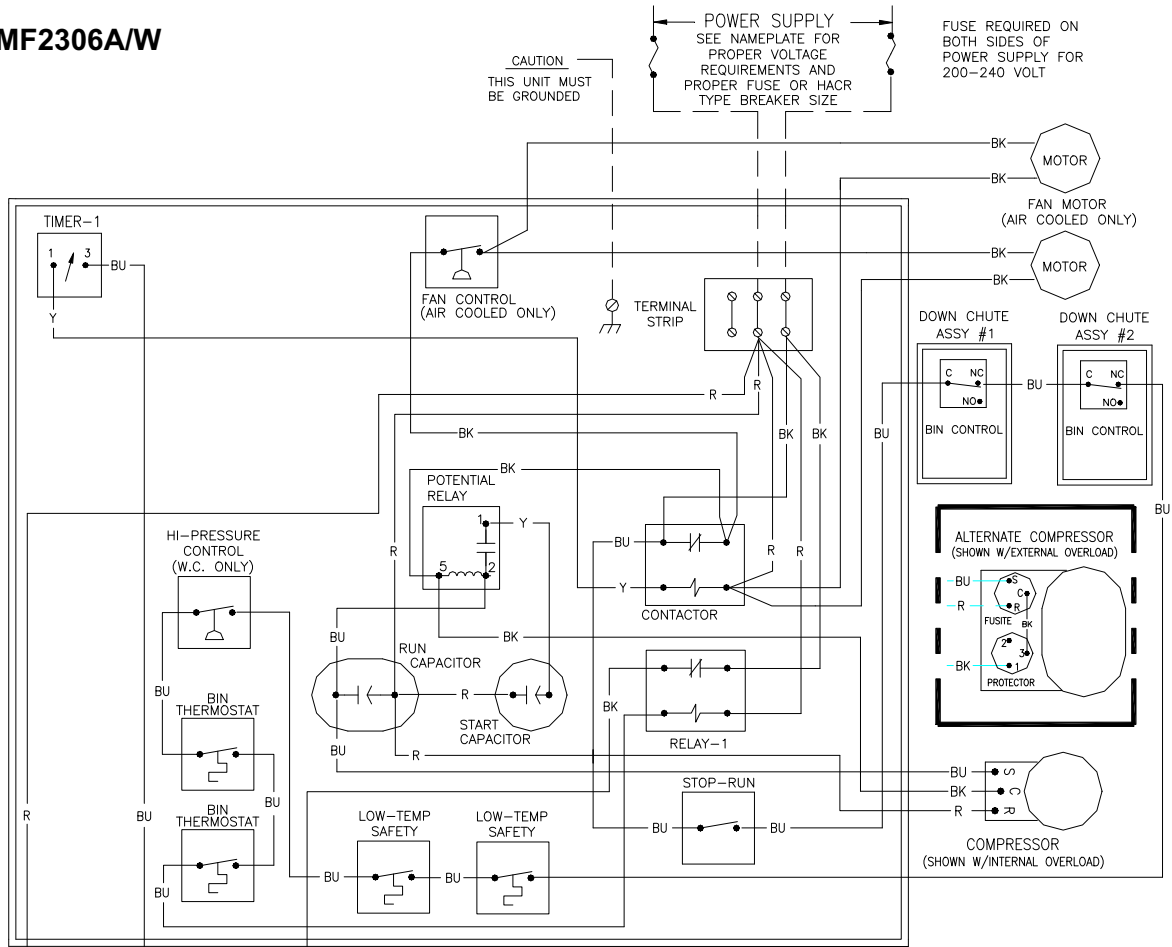

NOTE:
THIS MACHINE HAS A COMPRESSOR DELAY, AND WILL NOT BEGIN MAKING ICE UNTIL THE SET AMOUNT OF TIME ON TIMER-1 HAS PASSED.

CONTROLS SHOWN IN NORMAL ICE MAKING MODE

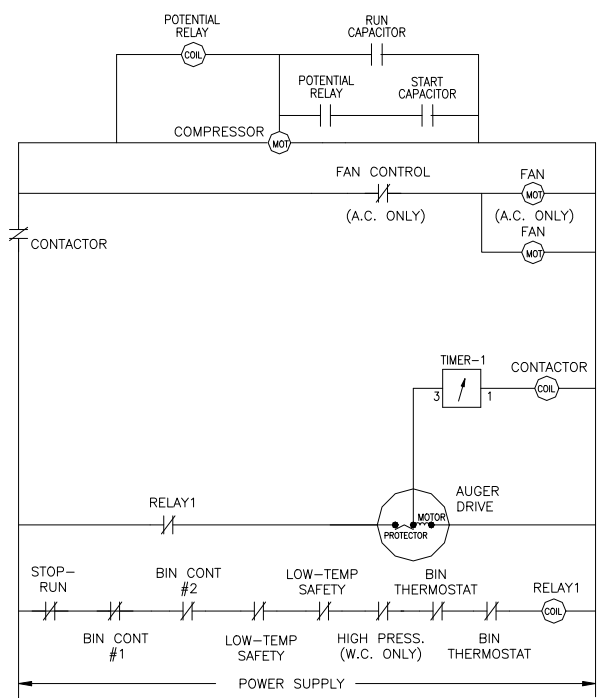

Flake Ice Machines

Electrical System

EMF2306R

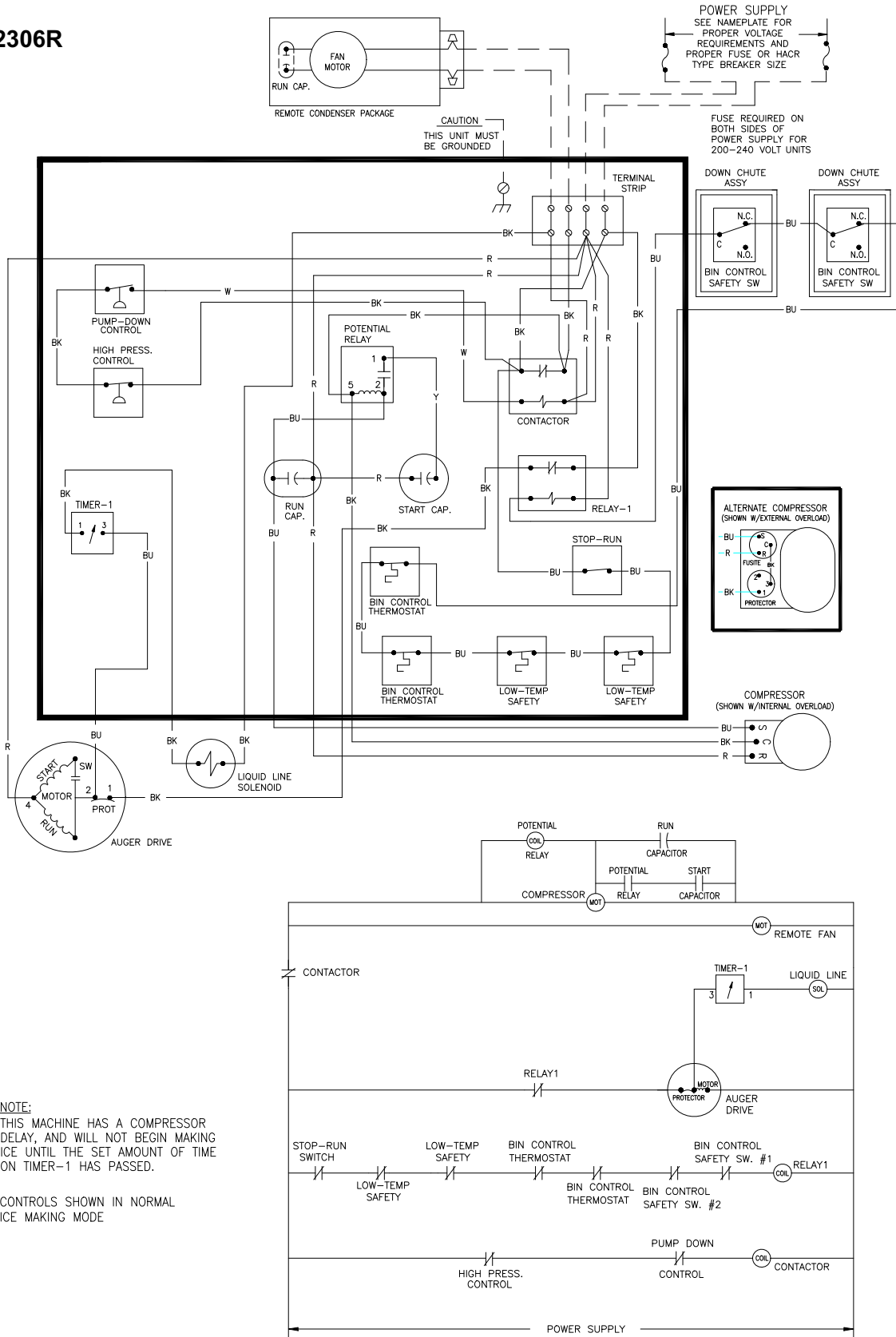

9071960-01

Flake Ice Machines

Electrical System

EMF2305L

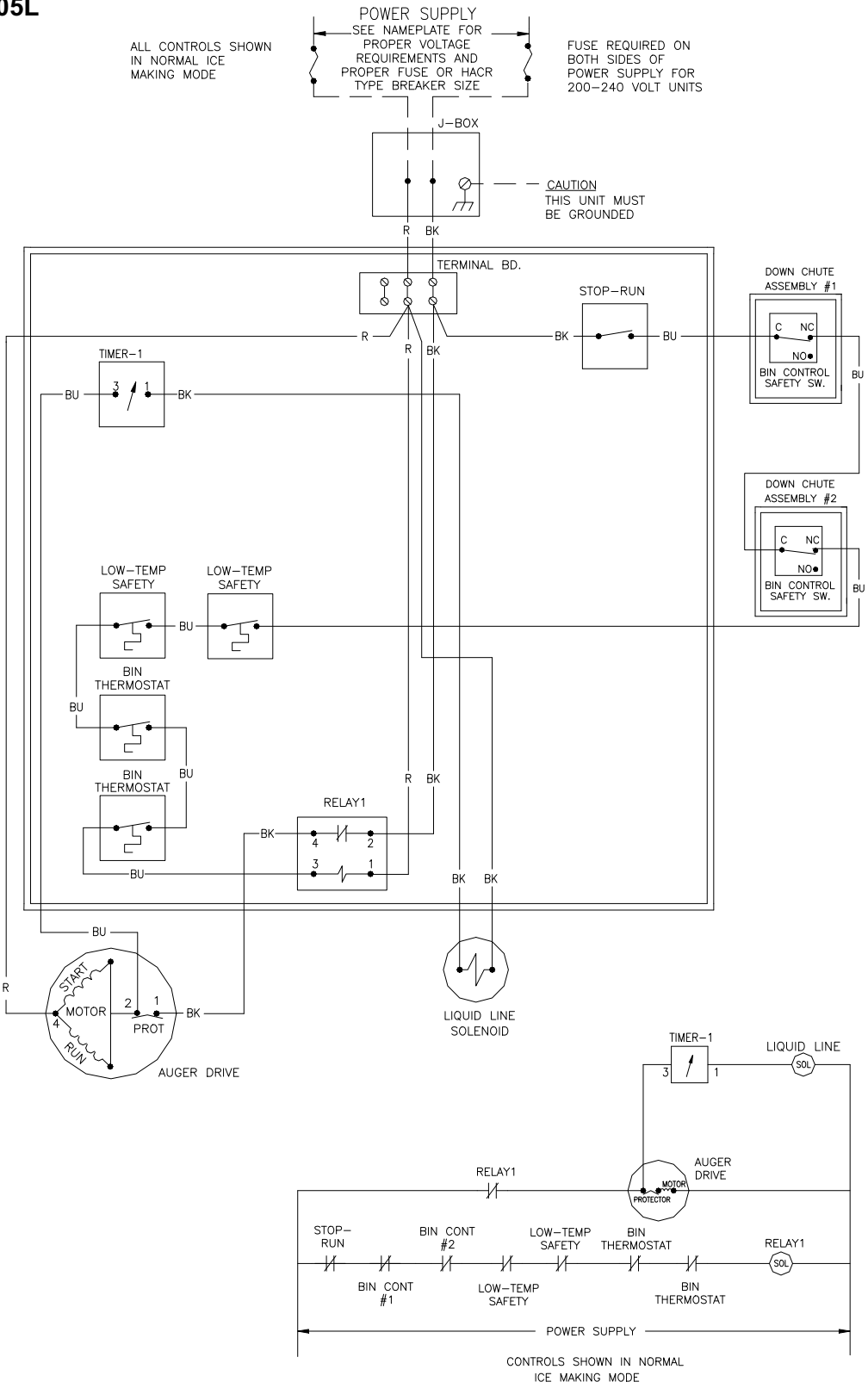

9071959-01

