

# ***Ice-O-Matic***<sup>®</sup>

## **Installation, Start-Up and Maintenance Manual EF and EMF Flaked Ice Machines Series 250 through 2306**



**Ice-O-Matic**  
11100 East 45th Ave  
Denver, Colorado 80239  
Part Number 9081178-01

**Print Date 10/08**

**How To Use This Manual**

Ice-O-Matic provides this manual as an aid to the service technician in installation and maintenance of the **EF and EMF Series** flake ice machines. Do not attempt to perform installation, start-up or maintenance unless you have read and fully understand this manual.

If at any time you encounter conditions that are not addressed in this manual, call, E-mail or write the Ice-O-Matic Service Department:

Ice-O-Matic  
11100 E. 45<sup>th</sup> Ave.  
Denver, Co. 80239  
Attn: Technical Service Department  
E-Mail: Tech.service@iceomatic.com

**Telephone Numbers**

800-423-3367 All Departments  
888-349-4423 Technical Assistance Only  
303-371-3737

Any Service communication must include:

- Model Number
- Serial number
- A detailed explanation of the problem

**Keep this manual for future reference.**

The EF and EMF Series Service Parts Manuals are available separately.

**Ice-O-Matic icemakers and dispensers are not approved for outdoor installation.**

**WARNING: Always disconnect electrical power and shut off water supply whenever maintenance or repairs are performed on the ice machine and related equipment.**

**CAUTION: Always wear protective eyewear whenever maintenance or repairs are performed on the ice machine and related equipment**

<b>Introduction</b>	Page i
<b>Table of Contents</b>	Page ii
<b>Freight Claim Procedure</b>	Page iii
<b>Warranty</b>	Page iv
<b>Model Number and Serial Number Format</b>	Page 1
<b>Installation Guidelines</b>	Page 2-3
<b>Remote Condenser Guidelines</b>	Page 4
<b>Electrical and Plumbing Requirements</b>	Page 5-7
<b>How the Machine Works</b>	Page 8
<b>Start-Up Procedure</b>	Page 9-10
<b>General Maintenance</b>	Page 11
<b>Cleaning Procedure</b>	Page 12
<b>Cabinet Care</b>	Page 13
<b>Winterizing Procedure</b>	Page 14
<b>Maintenance Record</b>	Page 15

**Important!****Inspect Promptly**

This merchandise has been carefully inspected and packed in accordance with the carrier's packing specifications. Responsibility for safe delivery has been assumed by the carrier. If loss or damage occurs, you as the consignee must file a claim with the carrier and hold container for carrier's inspection.

**Visible Loss or Damage**

Any external evidence of loss or damage must be fully described and noted on your freight bill or express receipt and signed by the carrier's agent. Claim should be filed on a form available from the carrier.

**Concealed Loss or Damage**

If loss or damage does not appear until merchandise has been unpacked, make a written request for inspection by the carrier within 15 days of the delivery date. Then file a claim on a form from the carrier.

**File Claim Without Delay****Do Not Return Damaged Merchandise to Ice-O-Matic**

**Ice-O-Matic  
Parts and Labor  
Domestic & International Limited Warranty**

Mile High Equipment LLC (the "Company") warrants Ice-O-Matic brand ice machines, ice dispensers, remote condensers, water filters, and ice storage bins to the end customer against defects in material and factory workmanship for the following:

<ul style="list-style-type: none"> <li>• Cube ice machines,"GEM" model compressed ice machines , " MFI" model flake ice machines and remote condensers. - Thirty-six (36) months parts and labor</li> </ul>	<ul style="list-style-type: none"> <li>• Ice storage bins -Twenty-four (24) month parts and labor</li> </ul>
<ul style="list-style-type: none"> <li>• "EF" and "EMF" model flake ice machines - Twenty-four (24) months parts and labor</li> </ul>	<ul style="list-style-type: none"> <li>• IOD model dispensers - Twenty-four (24) months parts, Twelve (12) months labor</li> </ul>
<ul style="list-style-type: none"> <li>• CD model dispensers - Thirty-six (36) months parts and labor</li> </ul>	<ul style="list-style-type: none"> <li>• Water filter systems - Twelve (12) months parts and labor (not including filter cartridges)</li> </ul>

An additional twenty-four (24) month warranty on parts (excluding labor) will be extended to all cube ice machine evaporator plates and compressors, "GEM" model compressed ice machine compressors, and "MFI" model flake ice machine compressors from the date of original installation. An additional thirty-six (36) month warranty on parts (excluding labor) will be extended to all "EF" and "EMF" model flake ice machine compressors from the date of original installation. The company will replace EXW (Incoterms 2000) the Company plant or, EXW (Incoterms 2000) the Company-authorized distributor, without cost to the Customer, that part of any such machine that becomes defective. In the event that the Warranty Registration Card indicating the installation date has not been returned to Ice-O-Matic, the warranty period will begin on the date of shipment from the Company. Irrespective of the actual installation date, the product will be warranted for a maximum of seventy-two (72) months from date of shipment from the Company.

ICE-model cube ice machines which are registered in the Water Filter Extended Warranty Program will receive a total of eighty-four (84) months parts and labor coverage on the evaporator plate from the date of original installation. Water filters must be installed at the time of installation and registered with the Company at that time. Water filter cartridges must be changed every six (6) months and that change reported to the Company to maintain the extended evaporator warranty.

No replacement will be made for any part or assembly which (I) has been subject to an alteration or accident; (II) was used in any way which, in the Company's opinion, adversely affects the machine's performance; (III) is from a machine on which the serial number has been altered or removed; or, (IV) uses any replacement part not authorized by the Company. This warranty does not apply to destruction or damage caused by unauthorized service, using other than Ice-O-Matic authorized replacements, risks of transportation, damage resulting from adverse environmental or water conditions, accidents, misuse, abuse, improper drainage, interruption in the electrical or water supply, charges related to the replacement of non-defective parts or components, damage by fire, flood, or acts of God.

*This warranty is valid only when installation, service, and preventive maintenance are performed by a Company-authorized distributor, a Company-authorized service agency, or a Company Regional Manager. The Company reserves the right to refuse claims made for ice machines or bins used in more than one location. This Limited Warranty does not cover ice bills, normal maintenance, after-install adjustments, and cleaning.*

Limitation of Warranty

**This warranty is valid only for products produced and shipped from the Company after January, 2007. A product produced or installed before that date shall be covered by the Limited Warranty in effect at the date of its shipment. The liability of the Company for breach of this warranty shall, in any case, be limited to the cost of a new part to replace any part, which proves to be defective. The Company makes no representations or warranties of any character as to accessories or auxiliary equipment not manufactured by the Company. REPAIR OR REPLACEMENT AS PROVIDED UNDER THIS WARRANTY IS THE EXCLUSIVE REMEDY OF THE CUSTOMER. MILE HIGH EQUIPMENT SHALL NOT BE LIABLE FOR ANY INCIDENTAL OR CONSEQUENTIAL DAMAGES FOR BREACH OF ANY EXPRESS OR IMPLIED WARRANTY ON THIS PRODUCT. EXCEPT TO THE EXTENT PROHIBITED BY APPLICABLE LAW, ANY IMPLIED WARRANTY OR MERCHANTABILITY OR FITNESS FOR A PARTICULAR PURPOSE ON THIS PRODUCT IS LIMITED IN DURATION TO THE LENGTH OF THIS WARRANTY.**

Filing a Claim

All claims for reimbursement **must be received at the factory within 90 days from date of service** to be eligible for credit. **All claims outside this time period will be void.** The model, the serial number and, if necessary, proof of installation, must be included in the claim. Claims for labor to replace defective parts must be included with the part claim to receive consideration. Payment on claims for labor will be limited to the published labor time allowance hours in effect at the time of repair. The Company may elect to require the return of components to validate a claim. Any defective part returned must be shipped to the Company or the Company-authorized distributor, transportation charges pre-paid, and properly sealed and tagged. The Company does not assume any responsibility for any expenses incurred in the field incidental to the repair of equipment covered by this warranty. The decision of the Company with respect to repair or replacement of a part shall be final. No person is authorized to give any other warranties or to assume any other liability on the Company's behalf unless done in writing by an officer of the Company.

**GOVERNING LAW**

This Limited Warranty shall be governed by the laws of the state of Delaware, U.S.A., excluding their conflicts of law principles. The United Nations Convention on Contracts for the International Sale of Goods is hereby excluded in its entirety from application to this Limited Warranty.

**Mile High Equipment LLC, 11100 East 45<sup>th</sup> Avenue, Denver, Colorado 80239 (303) 371-3737  
January 2007**

**Model and Serial Number Format**  
(Sample of Serial Number)

**MODEL NUMBER** EMF450AS2 

**SERIAL NUMBER** 04071280010077 

AC SUPPLY VOLTAGE ~ 115 HERTZ 60  
 TOTAL LOAD AMPS PHASE 1  
 MINIMUM CIRCUIT AMPACITY 14.1 WIRES 2  
 MAX FUSE SIZE OR HACR TYPE CIRCUIT BREAKER 15.0  
 HEATER WATTS

MOTORS	VOLTS	RLA/FLA	W/HP	LRA
1 COMPRESSOR	115	6.9		29.0
1 FAN DRIVE	115	.8	16W	
1 AUGER	115	4.6	1/4HP	

RATED POWER CONSUMPTION (KW)  
 REFRIGERANT R404A CHARGE/CIRCUIT 12 OZ 340 GRAMS  
 NUMBER OF REFRIGERANT CIRCUITS 1 

DESIGN PRESSURES	P.S.I.	-LO	450	-HI
BARS	17.7	-LO	31.6	-HI

 LISTED 361P  
 US  
 ICE MAKER WITHOUT STORAGE MEANS



MILE HIGH EQUIPMENT CO.  
 DENVER, COLORADO 80239  
 MADE IN U.S.A.

RATED ENERGY EFFICIENCY  
 (KWH/100 LB) 4.8 (KJ/KG) 396.8  
 MINIMUM BIN ENERGY EFFICIENCY (%) NA

Verified in Accordance With Energy Standard CAN/CSA 742-98 and  
 ARI 810-91 by Underwriters Laboratories Inc.  
 Approved City of Los Angeles Mechanical Testing Laboratory M-860074  
 Accepted for use City of New York Department of Buildings MEA 37-00-E

---

**MODEL NUMBER** EMF450AS2  
**SERIAL NUMBER** 04071280010077  
 VOLTS/HERTZ/PHASE 115/60/1 MAX FUSE SIZE 15.0  
 REFRIGERANT R404A CHARGE/CIRCUIT 12 OZ 340 GRAMS

 LISTED 361P  
 US  
 ICE MAKER WITHOUT STORAGE MEANS



The serial number format and machine specifics are detailed on the data plate.

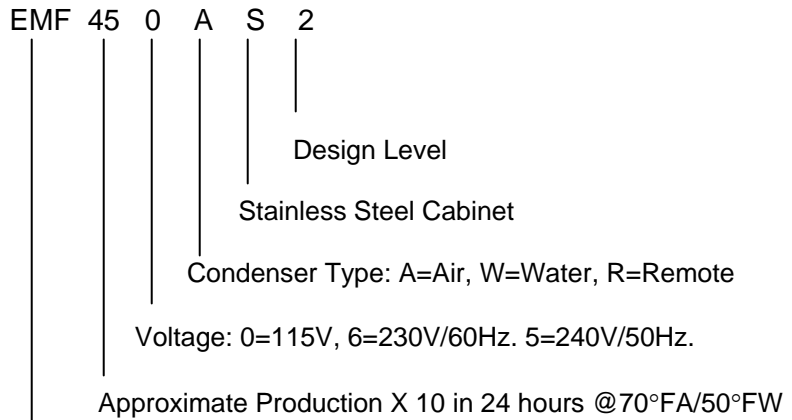

Series: Environmental Modular Flaker (Uses HFC Refrigerant)

This format is 14 characters long and begins with a date code followed by the Ice-O-Matic identifier, and then a sequential number. This is an entirely numerical serial number.

The new serial number will look like the example.

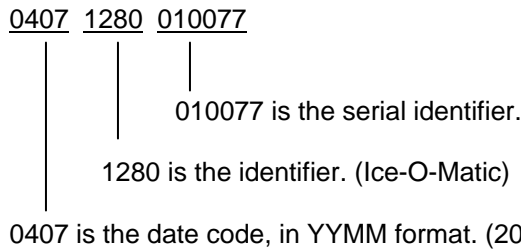

← Large data plate will be placed on the back of the unit.

← Small data plate will be placed by the service valves.

The date code will change monthly and yearly to reflect the date of manufacture.

## Installation Guidelines

For proper operation of the Ice-O-Matic ice machine, the following installation guidelines must be followed. Failure to do so may result in loss of production capacity, premature part failures, and may void all warranties.

Reference the installation parameters prior to installing the machine:

### Ambient Operating Temperatures

Minimum Operating Temperature: 50°F (10°C)

Maximum Operating Temperature 100°F (38°C), 110°F (43°C) on 50 Hz. Models.

**Note: Ice-O-Matic icemakers and dispensers are not approved for outdoor installation.**

### Incoming Water Supply (See Electrical and Plumbing Diagrams for line sizing)

Minimum incoming water temperature: 40°F (4.5°C)

Maximum incoming water temperature: 100°F (38°C)

Minimum incoming water pressure: 20 psi (1.4 bar)

Maximum incoming water pressure: 60 psi (4.1 bar)

**Note: If water pressure exceeds 60 psi (4.1 bar), a water pressure regulator must be installed.**

### Drains

Route bin drain, float overflow drain and water condenser drain individually to a floor drain. The use of condensate pumps for draining water is not recommended by Ice-O-Matic. Ice-O-Matic assumes no responsibility for improperly installed equipment.

### Water Filtration

A water filter system should be installed with the ice machine.

### Clearance Requirements

Self contained air cooled ice machines must have a minimum of 6 inches (15cm) of clearance at the sides of the ice machine for proper air circulation.

### Stacking

Ice-O-Matic flake ice machines are not designed to be stacked.

### Dispenser Application

Ice-O-Matic flake ice machines are not designed for dispenser application.

### Electrical Specifications

Refer to the serial plate at the rear of the ice machine to make sure proper voltage and circuit breaker size have been supplied. Make sure the machine is on a dedicated circuit. European installations require that the electrical supply fixed wiring must be provided with a disconnect means having a separation of at least 3mm in all poles.

The ice machines are provided without an electrical cord set and are designed and agency approved to be permanently connected.

**CAUTION:** Electrical connection must be made or a cord installed by a qualified electrician or there is danger of an electrical fire.

### Adjustments

Level the machine within 1/8 inch in all directions. Adjust the cabinet or bin legs as required.

Check the primary and secondary bin control for proper adjustment.

Check the water level in the reservoir for proper adjustment.

Check the safety control for proper adjustment.

Check the water regulating valve adjustment if water cooled.

**Set-Up**

- Carefully uncrate machine and check for visible damage. If any damage is noted, stop installation and follow instructions on Page iii.
- Remove skid bolts or screws and lift machine off of the skid.
- Install legs (packaged inside bin) on base of machine or storage bin.
- Remove and discard the 2 bolts at the rear of the EF series cabinet that secure the chassis for shipping.
- Place the EMF series model on top of the bin or bin top, install the downchute seal and attach the ice machine with the hardware provided. Insure that the back of the ice machine is flush with the back of the bin or bin top.

Install Junction Box

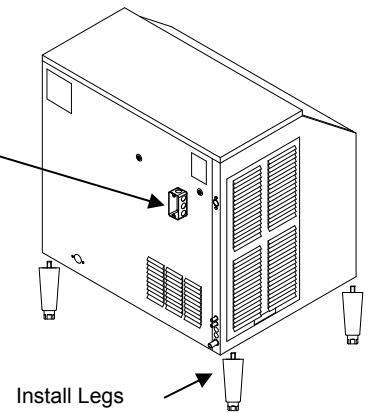

Install Legs

Proper functioning of the bin door requires the bin door, when it is opened, to be in a stable position. If the ice machine is too far forward on the bin, the opened door may not be stable, resulting in an unexpected closing of the bin door.

If the ice machine is to be mounted on a bin or dispenser other than an Ice-O-Matic, refer to the manufacturer's instructions for machine mounting. Ice-O-Matic will not be responsible for damage or injury that results from unexpected closing of the bin door as a result of the ice machine being too far forward on the bin.

**Danger!**

Electrical shock and/or injury from moving parts inside this machine can cause serious injury or death. Disconnect electrical supply to the machine prior to performing any adjustments or repairs.

**Important!**

All installations must comply with local and national electrical codes.

**European Installations**

The electrical supply fixed wiring must be provided with a disconnection means having a separation of at least 3mm in all poles.

**Electrical Connections**

1. Check for proper voltage, wire and fuse size according to the specifications listed on the serial data plate located on the rear of the ice machine cabinet.
2. Supply power to the ice machine on a dedicated electrical circuit. Only the ice machine should be on this circuit. Reference the electrical wiring diagram on the ice machine.
3. On EF models make electrical connections in the junction box, taped to the chassis frame. Mount the junction box to the rear of the machine cabinet with the provided hardware and install the line voltage flexible conduit to the junction box. On all other models secure the conduit or electrical cord to back of the machine at the 7/8 inch hole. Make electrical connections at the terminal block located in the electrical box.

**Important!**

A water filtration system should be installed with all ice machines. Check the filter manufacturer's instructions for proper installation of the filter system.

All water supply lines must be installed per local codes. Use 1/4 inch O.D. minimum on air cooled machines. On water cooled machines 3/8 inch O.D. minimum tubing must be run to the condenser. The water supply for the ice making can "T" off from the condenser line using 1/4 inch O.D. minimum tubing. Make 2 coils of extra tubing so that the machine can be pulled away from the wall if service is needed.

All drain lines must be installed per local codes. The Condenser drain on water cooled units should be 3/8 inch O.D. minimum. Drain line fittings on Ice-O-Matic bins are 3/4 FPT. The bin drain should be a minimum of 3/4 inch O.D. Cold water drains should be insulated to prevent sweating.

**Warning!**

Do not apply heat directly to the back of bin as damage may occur to plastic parts.

Insure the machine is level within 1/8 inch in all directions.

Remove any shipping or packaging material.

If the machine has a remote condenser, reference the Remote Condenser Installation Guidelines.

Once the machine has been installed follow the start-up procedures.



**Remote Condenser Installation**

The EMF1106R2 and EMF2306R2 remote ice makers incorporate the mixing valve in the condenser. This configuration allows up to a 100 foot calculated remote line set run. Reference the diagram below to calculate the maximum 100 foot line set run.

For proper operation of the Ice-O-Matic ice machine, the following installation guidelines must be followed. Failure to do so may result in loss of production capacity, premature part failure, and may void all warranties.

Remote condensers must be installed per local building codes. A two to four inch diameter roof penetration will be needed for refrigerant lines and electrical conduit. The penetration should be within two feet of where the condenser will be located. A roof jack must be installed at the penetration.

**Installation Guidelines**

- Ambient operating temperatures: -20°F (-28.9°C) to 120°F (48.9°C)
- Condenser Airflow: Condensers must have a vertical airflow.

<b>ICE Machine Model Number</b>	<b>Remote Condenser Model Number</b>
EMF1106R2	VRC1061
EMF2306R2	VRC2061

**Limitations for new remote machines that have the headmaster mounted in the condenser.**

- Maximum Rise is 35 feet.
- Maximum Drop is 15 feet.
- Maximum equivalent run is 100 feet.

**Formula for figuring maximum equivalent run is as follows:**

Rise x 1.7 + Drop x 6.6 + horizontal run = equivalent run.

**Examples:** 35 ft. rise x 1.7 + 40 ft. horizontal = 99.5 equivalent feet line run

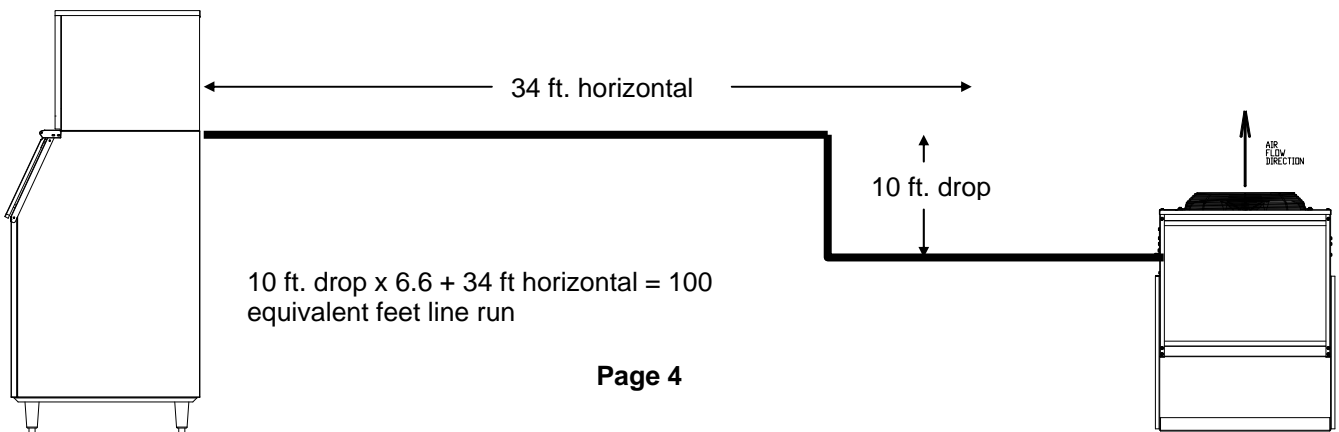
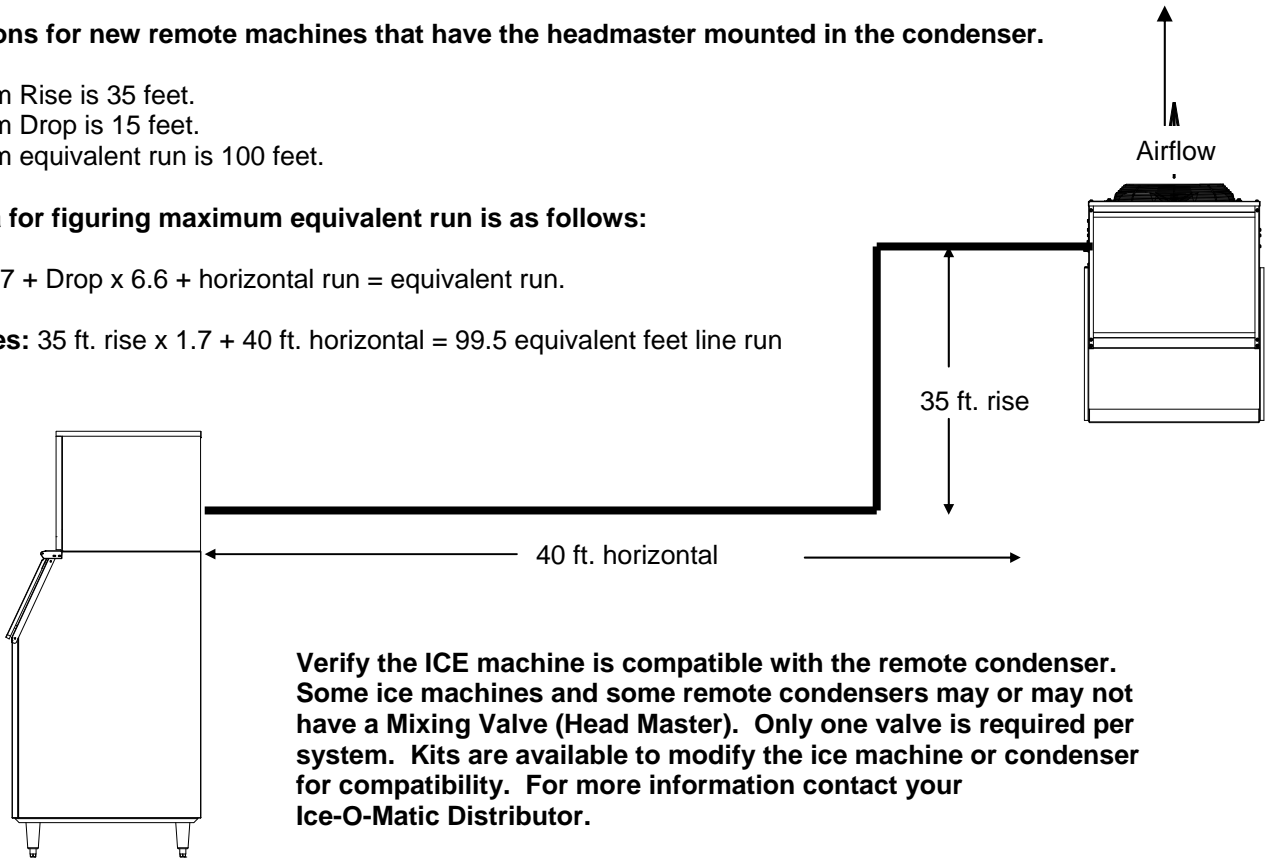

Electrical and Plumbing Requirements: 32, 38 and 48 inch Cabinets

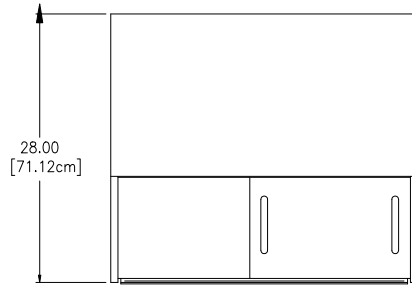

TOP VIEW

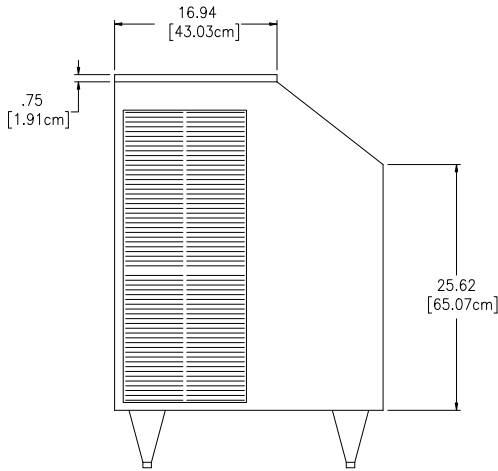

SIDE VIEW

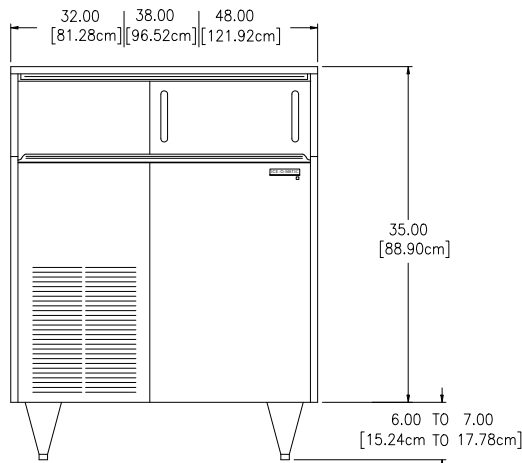

FRONT VIEW

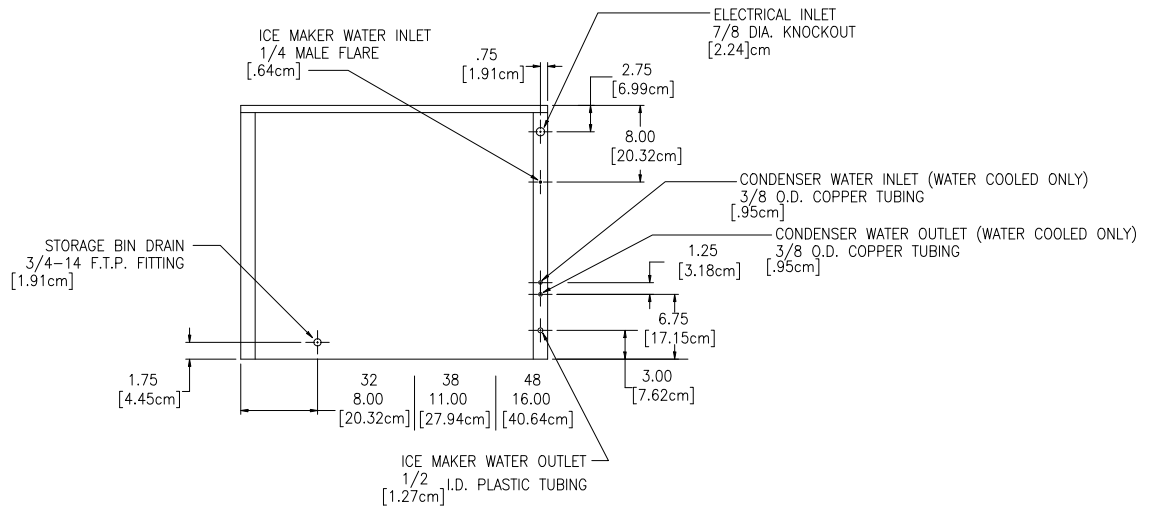

REAR VIEW

Electrical and Plumbing Requirements: EMF 450, 800 1106 Air, Water and Remote

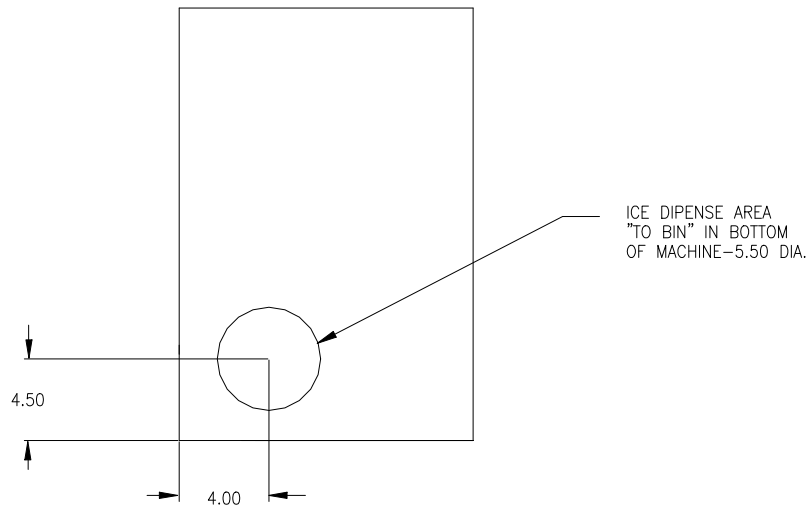

TOP VIEW

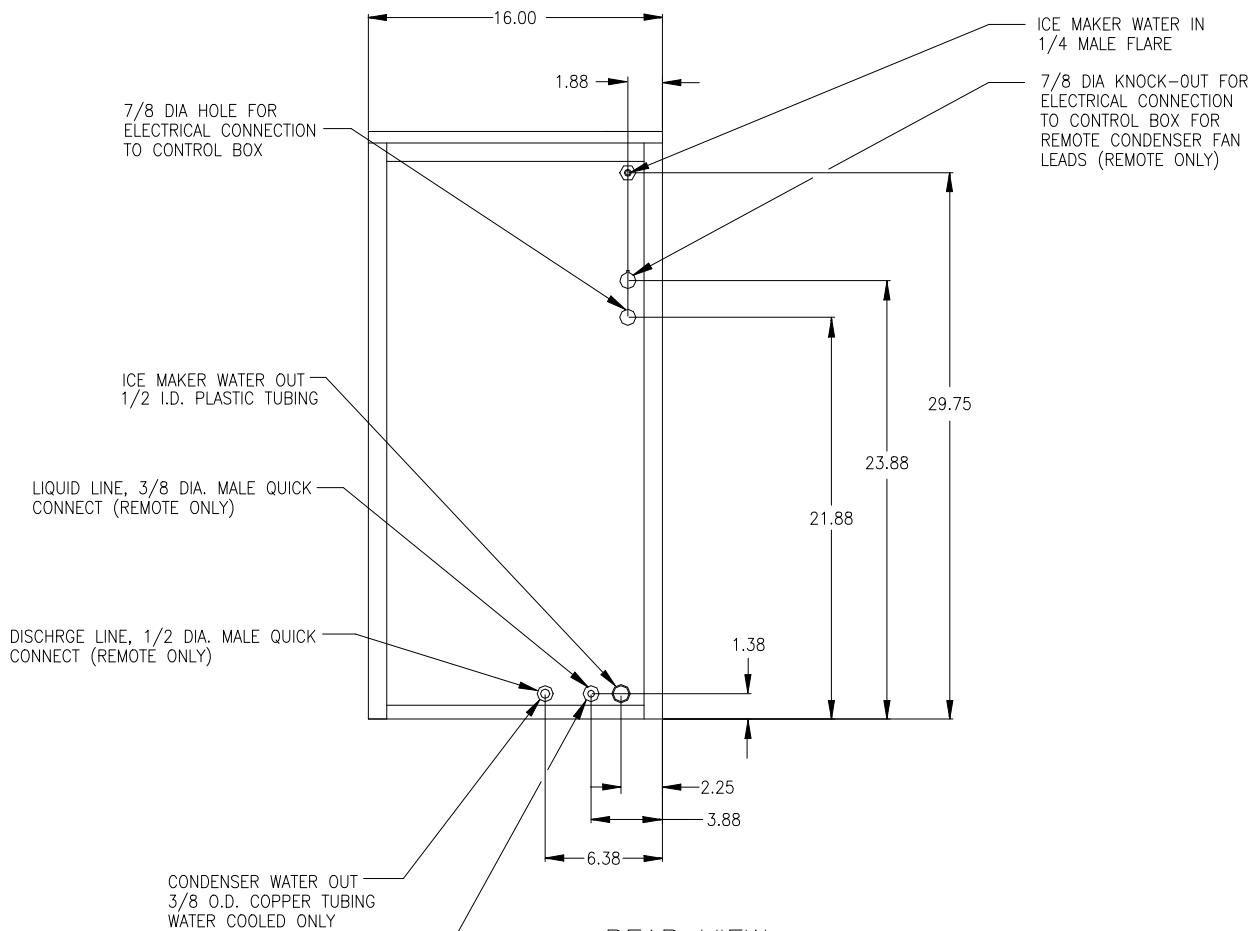

REAR VIEW

CONDENSER WATER IN  
3/8 O.D. COPPER TUBING  
WATER COOLED ONLY

Electrical and Plumbing Requirements: EMF2300 Air, Water and Remote

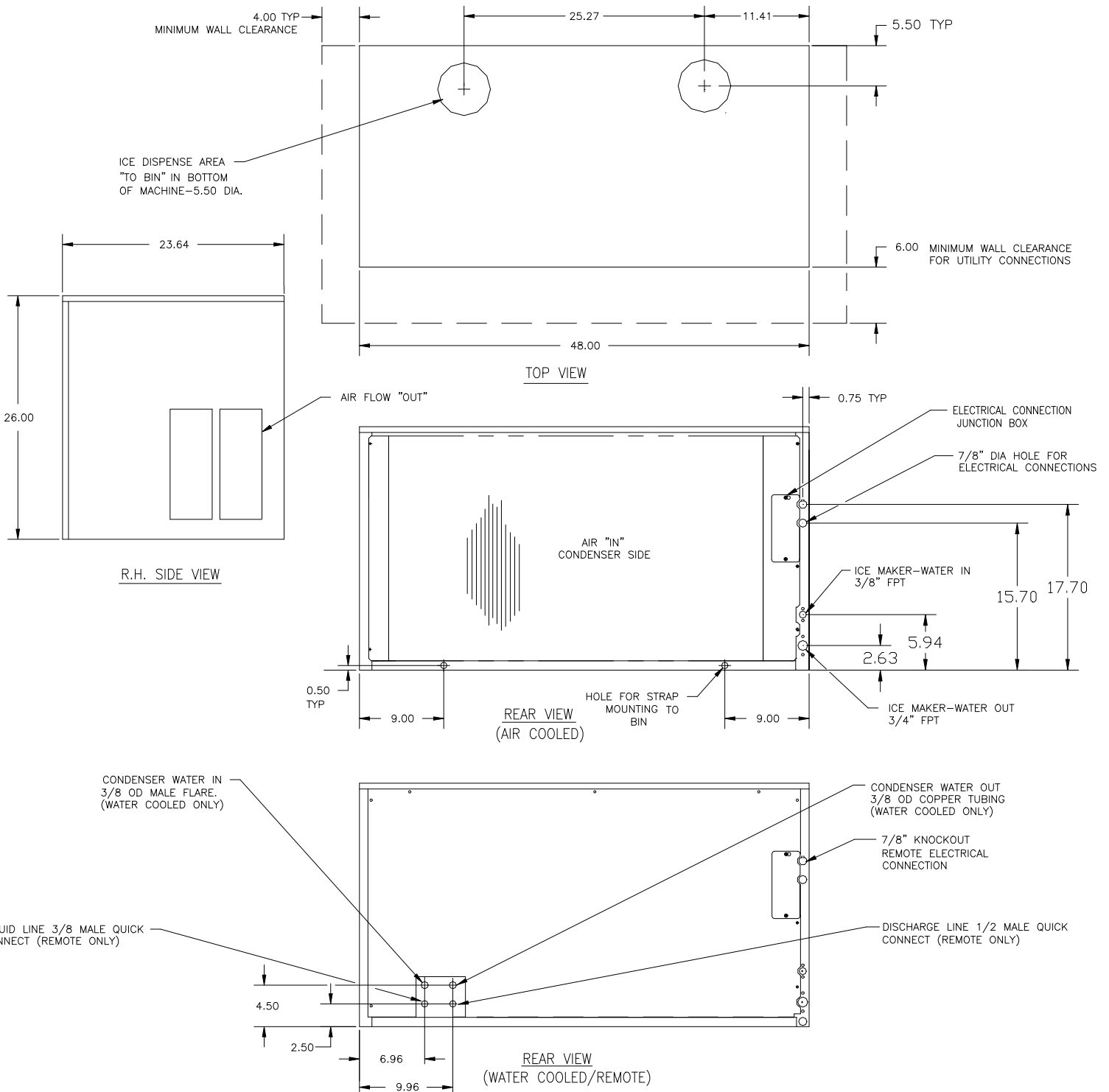

A general description of how the Ice-O-Matic Flaker works is given below:

Whenever the ON/OFF switch is in the ON position (and the bin control and safety controls are closed) the machine will continuously make ice and deliver it into the storage bin.

Water enters a reservoir through the float valve and is gravity fed into the evaporator barrel through an opening in the bottom of the barrel. Water fills the evaporator to the same level as the water in the reservoir. This level is maintained by a float valve which stops the flow of water into the reservoir when the reservoir becomes full.

When the ON/OFF switch is turned to the ON position, the auger motor energizes. On larger machines the compressor is delayed for 2 to 4 minutes. After the compressor delay period, the compressor and condenser fan motor (air cooled machines only) starts causing the temperature of the evaporator to drop.

The water in the evaporator freezes to the inner wall of the evaporator barrel. A belt driven gear reducer continuously turns the auger inside the evaporator. As the auger turns, it pushes the ice off of the barrel wall. The auger also drives the flakes of ice upward and forces them out of the window in the barrel, through the delivery chute and into the storage bin. As ice is pushed out through the evaporator, make-up water enters the bottom of the evaporator.

As the level of ice in the bin rises, the ice will contact the thermostatic bin control thermal well. The bin control then opens, shutting the machine off until ice is removed, allowing the bin control to once again close, starting the machine.

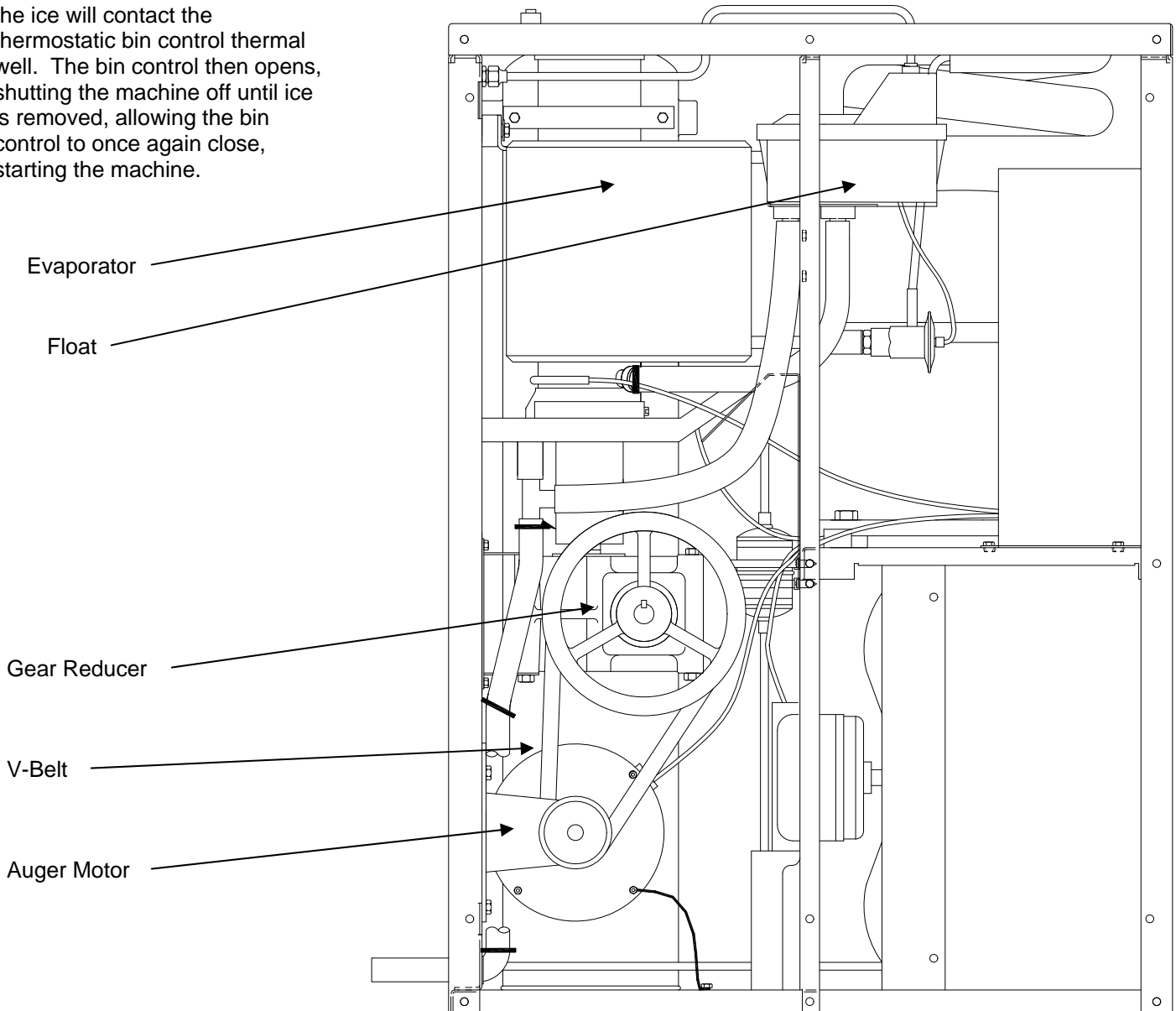

**EMF Series shown**

**Please Follow These Instructions Carefully**

- Check the auger assembly to insure that it turns freely. Turning the large pulley of the gear reducer should require only slight finger pressure.
- Check that the condenser fan turns freely.
- Remove tape and packing from the float valve and reservoir.
- Before turning the water supply on, check the low temperature safety control for proper operation:

Turn the machine ON. There may be a compressor delay of 2 to 4 minutes. Allow the machine to operate for 3 to 7 minutes after the compressor energizes. The safety control should open and shut down the ice machine within this time period. If the control does not open, rotate the adjustment screw counter-clockwise until the control opens. The safety control is located in the electrical control box and the capillary tube is in the thermal well at the bottom of the evaporator.

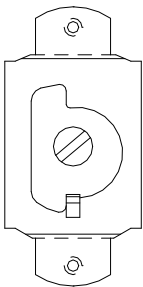
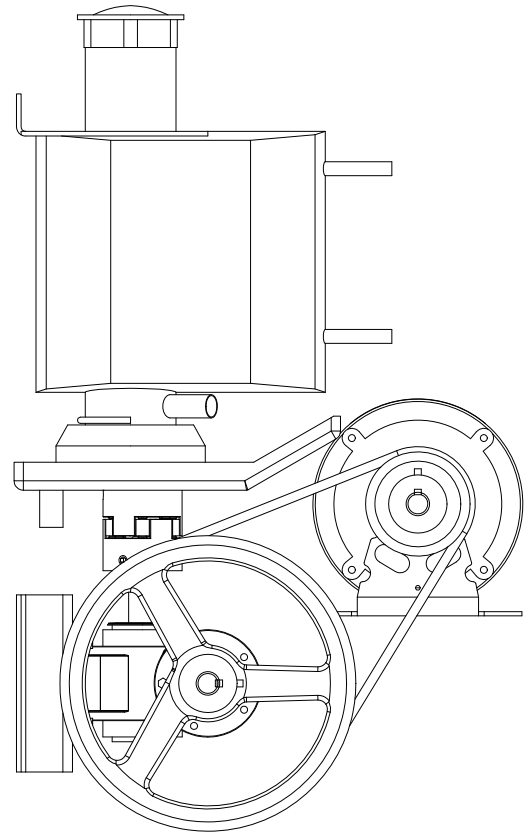

The Safety Control turns the machine off if the evaporator temperature reaches approximately 30° F (-1C). The Safety Control can be adjusted by turning the adjusting screw clockwise to lower the cut-out temperature (colder) or counterclockwise to raise the cut-out temperature (warmer).

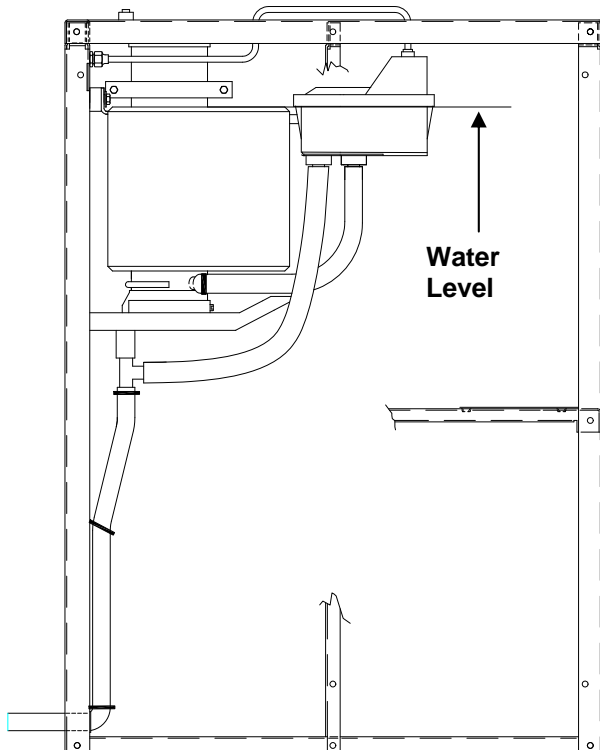

- Check the water level in the water reservoir.

Turn the water to the ice machine on. If this is a water cooled unit, insure that the water cooled condenser has an adequate water supply.

Turn the ON/Off switch ON, with the machine running and making ice, the water level in the reservoir should be even with the top of the insulation around the evaporator barrel.

If the water level is too low or too high, the water level may be adjusted lower or higher by adjusting the float mounting bracket.

Loosen or remove the two (2) screws securing the float bracket to the frame.

Raise or lower the float bracket so that the water level is even with the top of the insulation surrounding the evaporator.

Resecure the float bracket by tightening the screws.

- Check bin control for proper operation

The bin control is used to shut the machine off when the bin fills with ice. The bin control must be checked upon installation or initial start-up and when performing maintenance. **Adjustments are not covered under warranty.**

With the machine running and making ice, hold ice against the brass thermal well that houses the bin control capillary tube. The brass thermal well is located on the inside of the down chute on the EMF models and in the storage bin on the EF models. The machine should shut off in approximately 2 minutes. Remove the ice from the thermal well and the machine should come back on within 2 minutes. The bin control adjusting screw can be accessed through a hole in the control box. Note: On some models there will be a compressor delay of 2 to 4 minutes after turning the machine on.

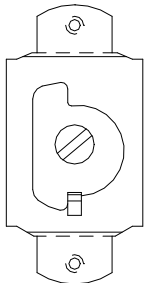

If ice is touching the bin control thermal well for more than 3 minutes and the machine has not shut off, turn the adjusting screw counter-clockwise approximately 1/8 turn and recheck.

- Check secondary bin control for proper operation

EF Series Flakers: With the machine off, reach inside the bin and push up on the white diaphragm located at the top of the bin. The switch contacts should change before the diaphragm is lifted 1/2 inch. Contacts should change again when the diaphragm is released. To adjust switch, remove cabinet top and move switch to proper position.

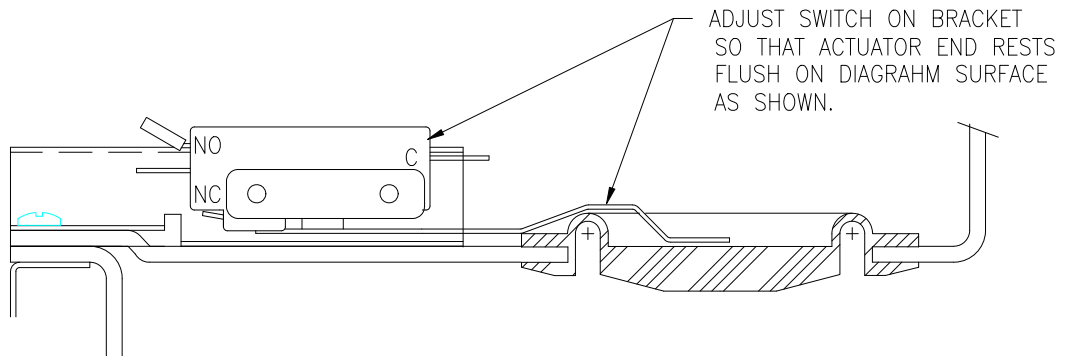

EMF Series Flakers: With the machine off, lift up slightly on the white diaphragm located on top of the down chute. The switch contacts should change before the actuator is lifted more than 1/2 inch. Contacts should change again when the diaphragm is released. To adjust switch, remove cabinet top and move switch to proper position.

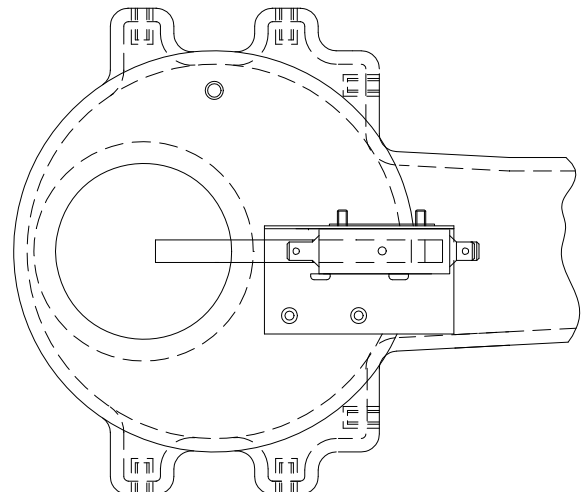

- Check for water leaks and excessive noise.

Electrical shock and/or injury from moving parts inside this machine can cause serious injury. Disconnect electrical supply to machine prior to performing any adjustments or repairs.



Failure to perform the required maintenance at the frequency specified will void warranty coverage in the event of a related failure.

### **General Maintenance Procedure**

To insure economical, trouble free operation of your machine, it is recommended that the following maintenance be performed every 6 months.

1. Clean the ice-making section per the instructions on the next page. Cleaning should be performed a minimum of every 6 months. Local water conditions may require that cleaning be performed more often.
2. Check the water level in the float reservoir.
3. Clean the condenser (air-cooled machines) to insure unobstructed air flow.
4. Check for leaks of any kind: Water, Refrigerant, Oil, Etc.
5. Check the bin control for proper adjustment.
6. Check the secondary bin control for proper adjustment.
7. Check the water valve (water-cooled machines) for proper adjustment by measuring the water temperature at the outlet of the condenser. It should be between 100°F and 110°F. (38°C and 43°C)
8. Check all electrical connections.
9. Oil the fan motor if the motor has an oil fitting. (Self contained air-cooled models only)
10. Check the water filter (if applicable) and replace if dirty or restricted.
11. Check the safety control for proper adjustment.



**ICE Machine Cleaning and Sanitizing Instructions**

It is the USER'S RESPONSIBILITY to see that the unit is properly maintained. It is always preferable and less costly in the long run, to avoid possible down time by keeping it clean and adjusted as needed; and by replacing worn components before they can cause failure. The following is a list of recommended maintenance that will help keep the machine running with a minimum of problems.

Maintenance and Cleaning should be scheduled at a minimum of twice per year.

**CAUTION: Protective eyewear and gloves should be worn when using cleaning products.**

**CLEANING AND SANITIZING INSTRUCTIONS**

1. Turn the machine and water supply to the float off.
2. Remove or melt all ice in the bin.
3. Prepare one gallon (3.75l) of non-chlorine ice machine cleaner i.e. Nu-Calgon Nickel Safe, as directed on container.
4. Turn the machine on, remove the float reservoir cover and add cleaning solution to the reservoir.
5. As the machine makes ice, keep the reservoir filled with the cleaning solution until the entire gallon is used up.
6. Turn the machine off.
7. Prepare 1 gallon (3.75l) of approved (U.S. FDA 21 CFR, 178-1010) food equipment sanitizer to form a solution with 100 – 200 ppm free chlorine yield. Reserve about 1/3 gallon for step #13 below.
8. Turn the machine on and add the sanitizer to the reservoir, keeping the reservoir filled with sanitizer until 2/3 gallon is used up.
9. Turn the machine off.
10. Replace the float reservoir cover and turn the water supply back on.
11. Turn the machine on and allow the machine to make ice for 15 minutes.
12. Turn the machine off and remove and discard all of the ice from the bin made during the cleaning operation.
13. Clean the inside of the bin, bin door, and door frame with warm soapy water and rinse.
14. Using the remainder of the sanitizing solution, wipe all areas of the bin liner, door and door frame, etc. and rinse.
15. Turn machine back on.

**▲WARNING**

**Ice Machine Cleaner contains acids.  
KEEP OUT OF THE REACH OF CHILDREN  
Refer to ice machine cleaner  
manufactures emergency instructions on  
container label.**

**Cleaning stainless steel**

Commercial grades of stainless steel are susceptible to rusting if not properly maintained. It is important that you properly care for the stainless steel surfaces of your ice machine and bin to avoid the possibility of rust or corrosion. Use the following recommended guidelines for keeping your stainless steel looking like new:

- 1. Clean the stainless steel thoroughly once a week.** Clean frequently to avoid build-up of hard, stubborn stains. Also, hard water stains left to sit can weaken the steel's corrosion resistance and lead to rust. Use a nonabrasive cloth or sponge, working with, not across, the grain.
- 2. Don't use abrasive tools to clean the steel surface.** Do not use steel wool, abrasive sponge pads, wire brushes or scrapers to clean the steel. Such tools can break through the "passivation" layer - the thin layer on the surface of stainless steel that protects it from corrosion.
- 3. Don't use cleaners that use chlorine or chlorides.** Don't use chlorine bleach or products like Comet to clean the steel. Chlorides break down the passivation layer and can cause rusting.
- 4. Rinse with clean water.** If chlorinated cleansers are used, you must thoroughly rinse the surface with clean water and wipe dry immediately.
- 5. Use the right cleaning agent.** The table below lists the recommended cleaning agents for common stainless steel cleaning problems:

<b>Cleaning Activity</b>	<b>Cleaning Agent</b>	<b>Method of Application</b>
Routine cleaning	Soap, Ammonia, Windex, or detergent with water. Fantastik, 409 Spic'nSpan Liquid are also approve for Stainless Steel.	Apply with a clean cloth or sponge. Rinse with clean water and wipe dry.
Removing grease or fatty acids	Easy-Off or similar oven cleaners.	Apply generously, allow to stand for 15-20 minutes. Rinse with clean water. Repeat as required.
Removing hard water spots and scale.	Vinegar	Swab or wipe with clean cloth. Rinse with clean water and dry.

## Winterizing Procedures

### Important!

Whenever the ice machine is taken out of operation during the winter months, the procedure below must be performed. Failure to do so may cause serious damage and will void all warranties.

1. Turn off water to machine.
2. Make sure all ice is out of the evaporator(s).
3. Place the ON/OFF switch to the “**OFF**” position.
4. Disconnect the tubing between the evaporator and float.
5. Drain the water system completely.
6. On water cooled machines, hold the water regulating valve open by prying upward on the water valve spring with a screwdriver while using compressed air to blow all the water out of the condenser.
7. Remove all of the ice in the storage bin and discard.

