

# ***Ice-O-Matic***<sup>®</sup>

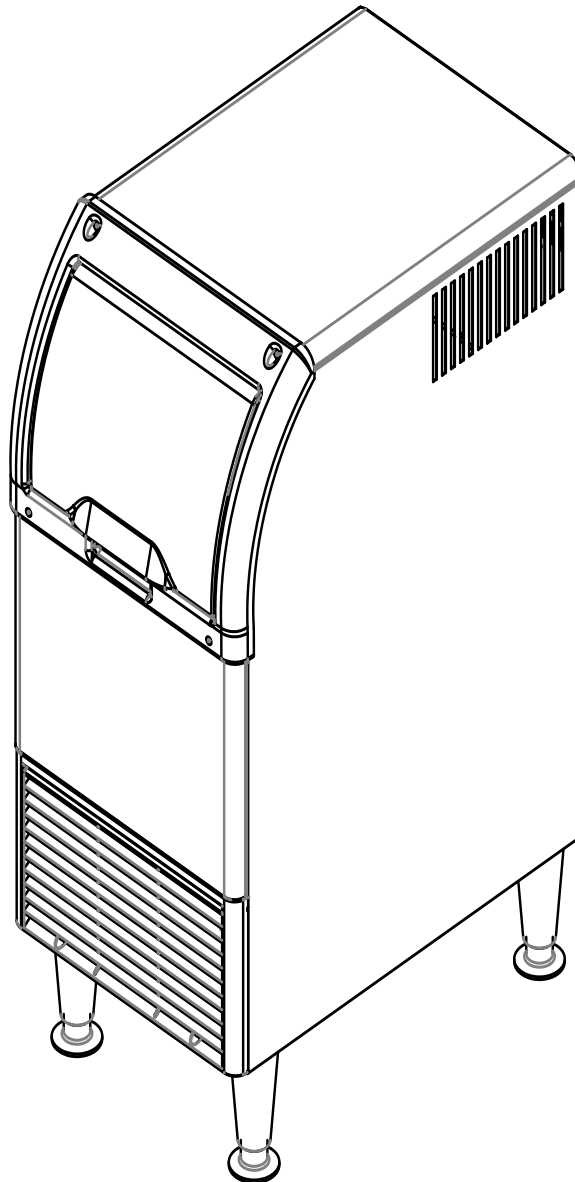

**Ice. Pure and Simple<sup>™</sup>**

## **Installation and User's Manual for Cube Ice Undercounter with Storage Models CIU050, CIU070 and CIU090**



**Introduction**

The design of this product is the result of years of experience in developing commercial ice cube machines. It has been designed for simple operation in a wide range of locations. Please follow the instructions for installation and maintenance to get the most use from this ice machine.

**Table of Contents**

Important Details ..... 2

Pre-Installation ..... 3

Cabinet Layout, CIU050 AND CIU070 ..... 4

Cabinet Layout, CIU090..... 5

Component Location..... 6

Water Supply Connection ..... 7

Power Connection..... 8

Control Panel and Adjustments..... 9

Initial Start Up ..... 11

Use and Operational Notes..... 12

Maintenance ..... 13

Before calling for service..... 15

115/60/1 Wiring Diagram ..... 16

## **Important Details**

The machine is designed for indoor use only. Machine must be in a controlled environment. It must be kept dry and stored in proper working temps listed below. The water and power supply must be maintained or the machine will stop making ice.

The following environmental limitations for air temperature and water temperature and voltage.

- Minimum air temperature: 50°F or 10°C
- Maximum air temperature: 100°F or 38°C.

There are also limits to how hot or cold the water supply can be:

- Minimum water temperature: 40°F or 4.5°C
- Maximum water temperature: 100°F or 38°C.

### **Voltage: 115-120 Volts**

Water supply must be potable by the localities definition.

There are limits to the water pressure supplied to the unit:

- Maximum pressure, static: 60 psi or 4.1 bar or 413.6 kilopascals.
- Minimum pressure, dynamic: 15 psi or 1 bar or 103.4 kilopascals.

A drain will be needed for melted ice and rinse water.

Operation outside these limitations, may damage the unit.

---

- **It is not recommended to connect a water softener because the ice may be more wet and slushy than desired.**
  - **Water Softeners add salinity lowering the freeze point resulting in “softer” ice. This results in lower ice production.**
  - **An Ice-O-Matic water filter is recommended.**
  - **This is not an individual cube machine, it is a slab cuber machine.**
  - **To be covered under warranty: Installation must be performed by a company authorized service representative or a refrigeration service company as qualified by the company.**
- 

### **Warranty:**

The warranty statement for this product is provided separately from this manual. Refer to it for applicable coverage. In general, warranty covers defects in material or workmanship. It does not cover maintenance, corrections to installations, or situations when the machine is operated in circumstances that exceed the limitations printed above.

The manufacturer has designed and produced this machine with the finest in materials. The manufacturer assumes no liability for units that have been altered in any way. Alterations or part substitutions will void the warranty. Specifications and designs are subject to change without notice.

**Pre-Installation**

This appliance is intended to be used in commercial applications including:

- Restaurant kitchens
- Bars
- Hotels

**Dimensions and Electrical:**

Model	Electrical (volts/Hz/Phase)	Width (in / cm)	Depth (in/cm)	Height (in/cm)	Total Load Amps
CIU050FA	115/60/1	15 / 38	23.7 / 60.3	31.9 / 81.1	4
CIU070FA	115/60/1	15 / 38	23.7 / 60.3	31.9 / 81.1	4
CIU090FA	115/60/1	20 / 51	23.7 / 60.3	31.9 / 81.1	4

**Location:**

The unit can be built into a cabinet as the air flow is in and out the front. The front of the machine must not be blocked. Certain maintenance or repair procedures will require removal of the top, back and side panels, so plan ahead for service and maintenance needs.

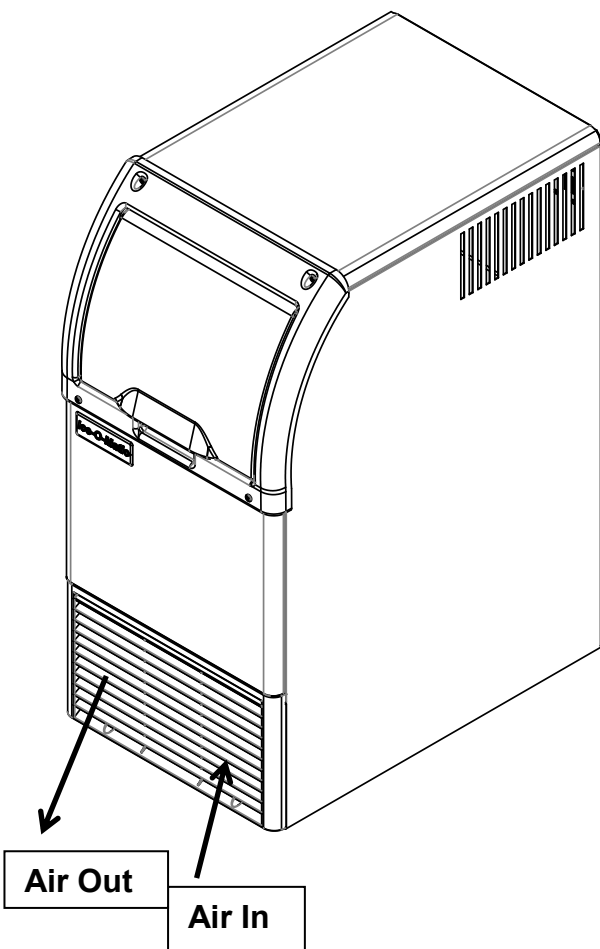

**Spacing:**

No additional spacing is required at the top or sides. However, suggested minimum side clearance for installation is 1/8 inch or 3 mm and suggested minimum top clearance is 1/4 inch or 7 mm.

Allow 4 inches (100 mm) minimum space at the back for the utility connections. Do not block louvers at the front of the cabinet.

**Unpacking and setup**

Remove all shipping and packing materials that may be in the ice storage bin.

The unit can be installed with or without legs. An optional floor mounting kit is also available to fill the gap between the machine and floor if not using legs.

If using legs, carefully tip the machine and install the legs by screwing them into the leg sockets in the bottom of the machine.

For reference, the thread size is 1/2-13

If the system has been on its side or back for longer than 1 hour, the unit must be left off for 24 hours before starting.

Place the machine in its intended location and level it front to back and left to right within an 1/8 of an inch. If using legs, adjust their feet in and out to level the cabinet.

If legs are not used the bottom edges of the cabinet must be sealed to the floor.

If built into a cabinet, the adjacent cabinet walls will provide the means for containment. There are no means for attachment to the cabinet.

**Cabinet Layout, CIU050 AND CIU070**

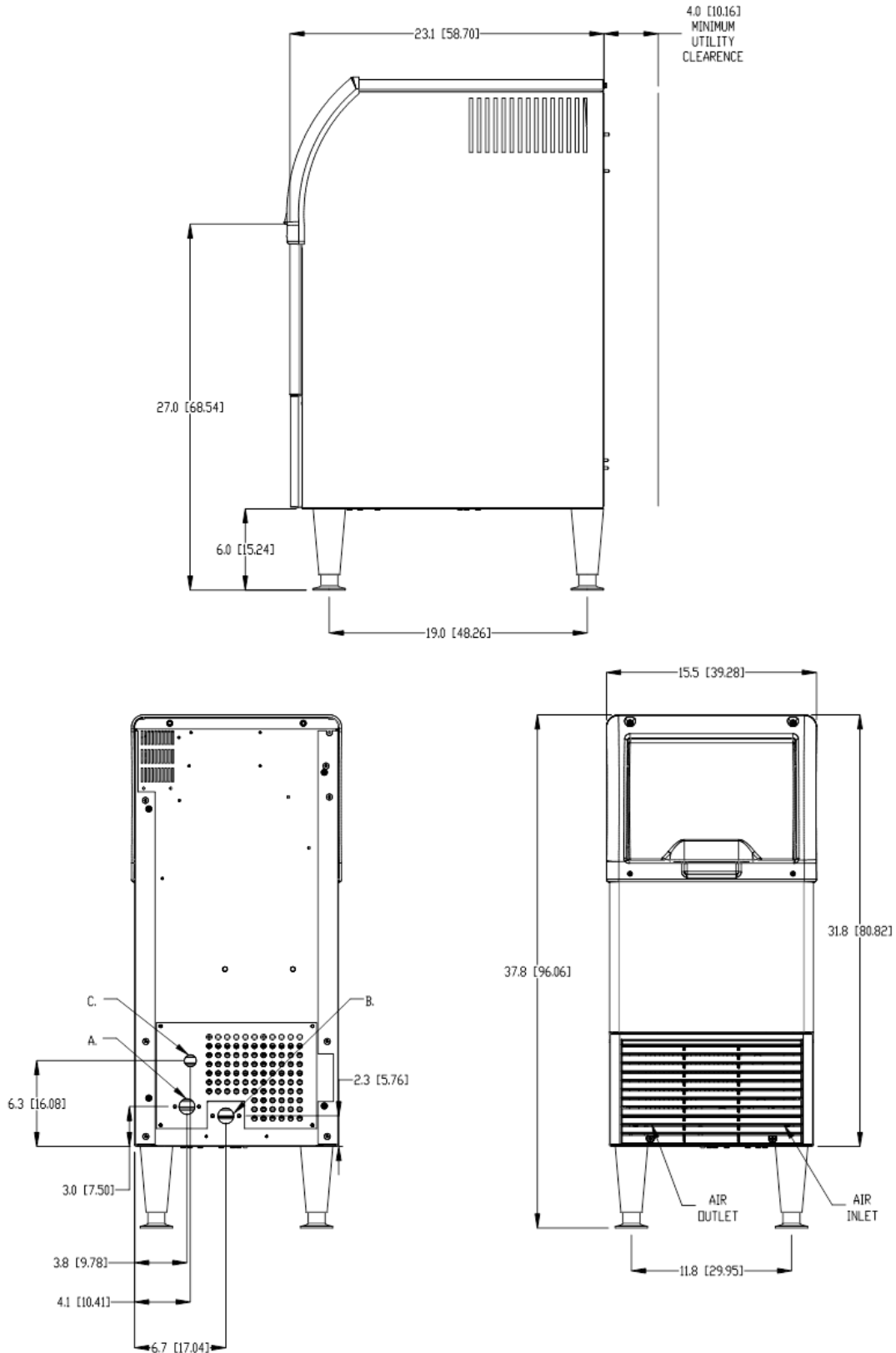

**Cabinet Layout, CIU090**

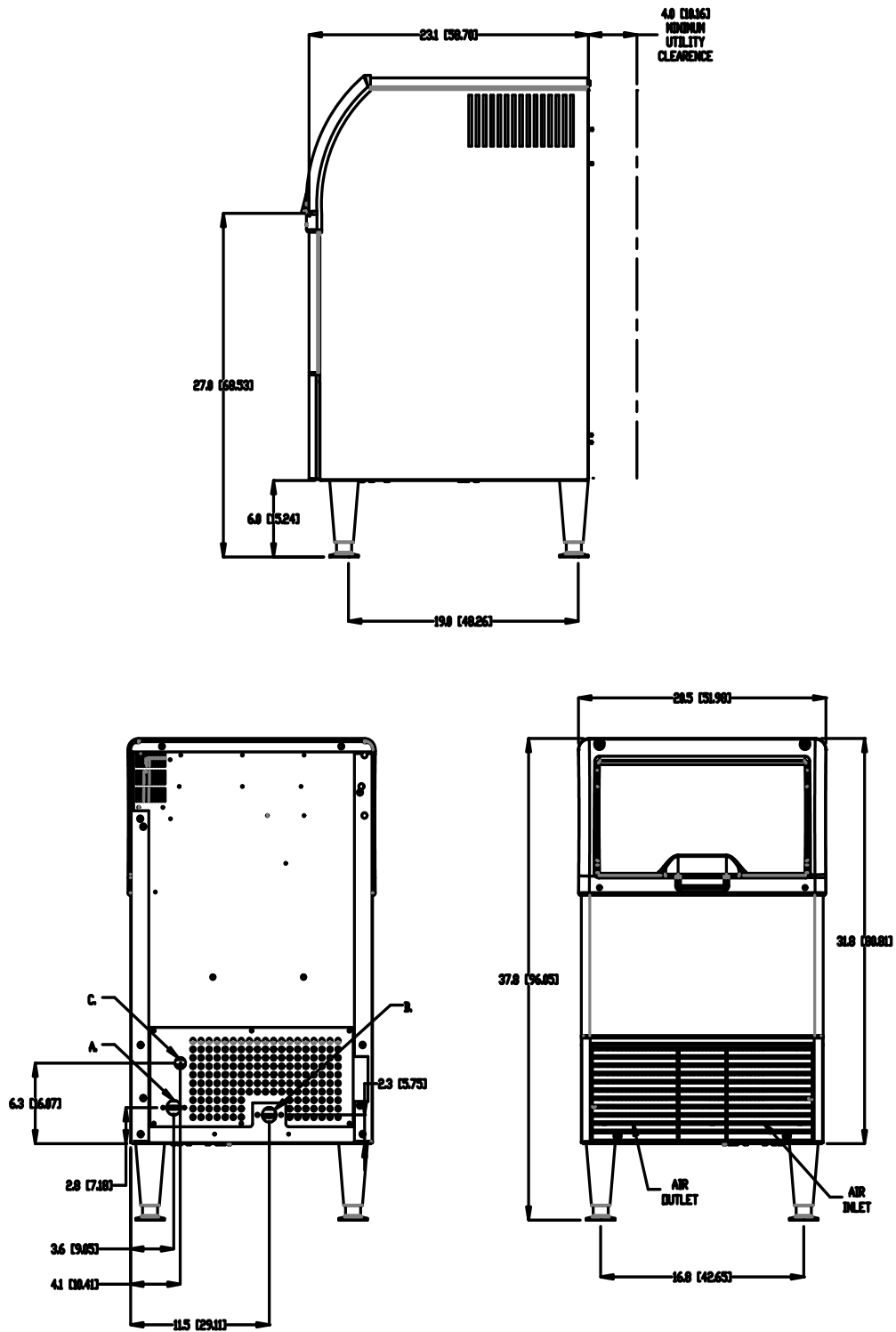

**Component Location**

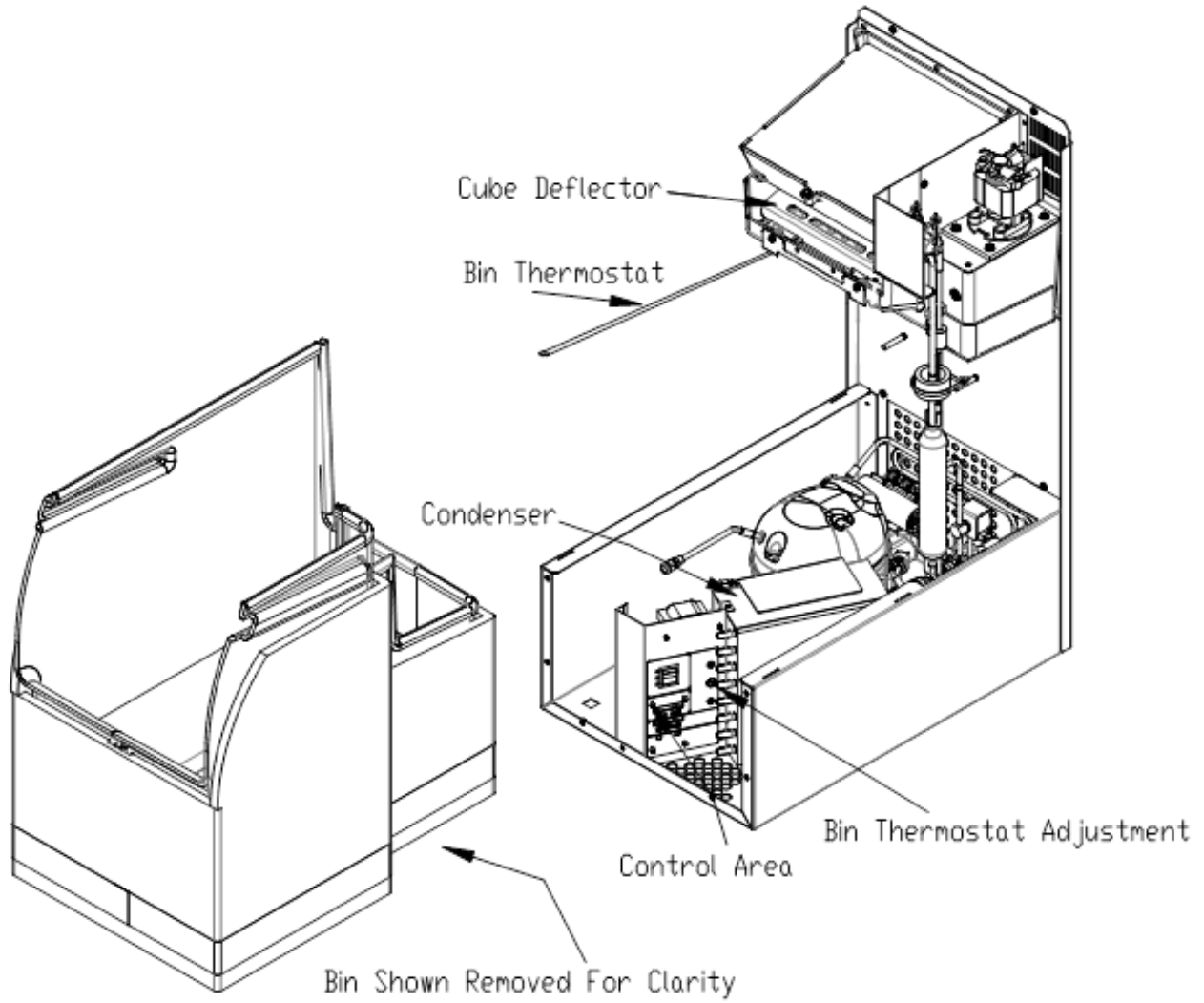

## **Water Supply Connection**

### **Plumbing information:**

There is a single 3/4 gas BNF inlet water connection.

**Note: If required, a connecting hose kit is sold separately. Kit Part Number, 2101488-02.**

- A hand actuated valve (Not Supplied with unit. Field Supplied) must be installed within sight of the machine to isolate unit when service is required.

- The machine has a built-in back flow preventer (an air gap between the end of the water inlet hose and the top of the water), no additional back flow preventer is needed.

Units that are built into a cabinet:

Include a loop or coil of tubing between the water supply and the connection on the ice machine. When the machine is pushed back into the cabinet the tubing will coil and should not be kinked.

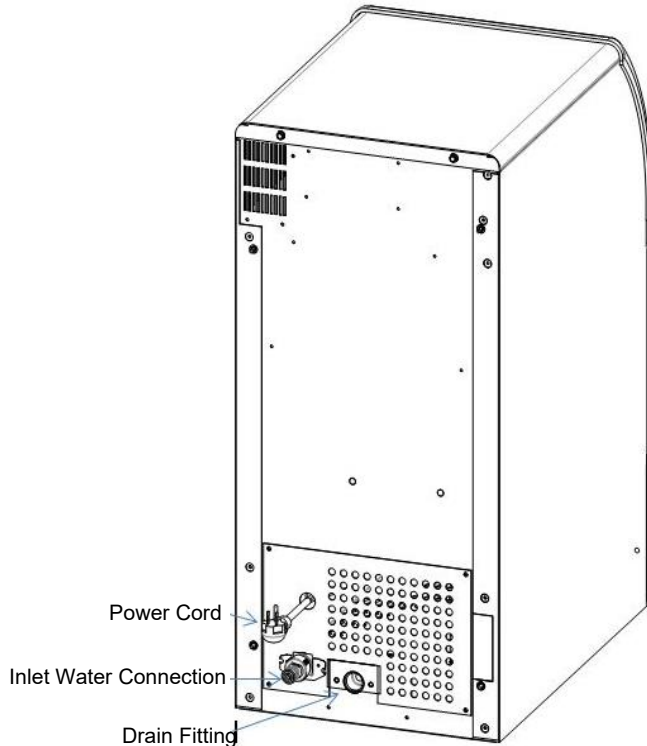

### **Connection Information:**

**WARNING:** connect to potable water supply only.  
**Important: Open the hand water valve to flush water through the tubing before connecting to the ice machine.**

---

**Note: Do not use a piercing-type saddle valve to connect to the building's water supply. Valves of that type restrict water flow and clog easily.**

---

### **Connect the drain**

The drain connection is at the back panel. The fitting size is 3/4 FPT. Connect rigid tubing to this fitting and vent it at the machine, use an 8 inch or 200 mm vertical tube for the vent.

Drain tubing must slope down from the ice machine to the building drain and the slope must be at least 1/4 inch per foot or 20 mm per meter. Insulating the rigid drain tubing will reduce condensation and is recommended for environments that have high humidity.

Due to the potential for leaks, condensate pumps are not recommended.

If flexible tubing is being used, follow the instructions above.

The floor drains must be large enough to accommodate drainage from the drain line.



## **Connect the power**

This is a cord-connected unit, and must be connected to its own dedicated power supply. A GFI outlet is not approved. Check the dataplate on the back of the machine for the voltage and maximum fuse size and per the dataplate use fuses or HACR circuit breakers.

### **Power Cords:**

**Note: In case the power cord is damaged, it must be replaced. Replacement cords are available from the manufacturer's local representative. Replacement should only be done by a qualified technician to prevent possible risk of electrical shock or misuse.**

The power cord plug will be the disconnect means for the machine and must be accessible when the unit is in its permanent location.

**Follow All Local Codes - This Unit Must Be Grounded.** Do not use extension cords and do not disable or by-pass ground prong on electrical plug.

Plug the power cord into the power supply.

### **Installation checklist**

- Has the machine been installed indoors in a suitable environment?
- Have all of the shipping items and packaging been removed?
- Is the ice deflector in the correct position?
- Is the plastic curtain hanging down and free to move?
- Has the water supply been connected and confirmed to not leak?
- Has a properly sized and sloped drain tube been attached?
- Has the correct voltage power supply been connected?

## Control Panel Adjustments

### Initial Startup Settings

Control box is located inside the lower louvered front panel. Remove the louvered panel by removing the two black screws located at the bottom of the panel.

### Adjustment Indicator Lights

Each push and release of the + or - button will change the lights that glow or blink indicating a change in ice size or harvest time. Example: A blinking light is equal to the value 1. A solid light indicates the value 2. If the lights are on steady, a single push of + will add one more blinking light to the right, which represents a value of 3. There are a total of 10 settings. All 5 lights on steady is the maximum setting and one blinking light is the minimum.

### Startup Settings

The followings settings are recommended for initial startup. Ensure the control box displays the following:

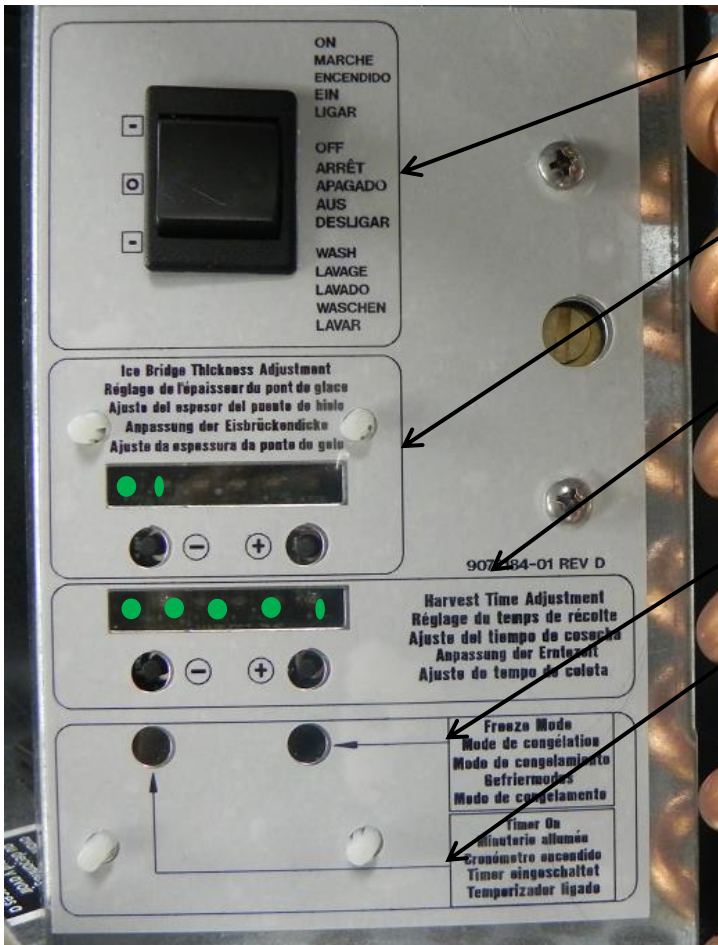

### Switch ON-OFF WASH

Move to ON to make ice, OFF (centered) to shut off and WASH to clean.

### Ice Bridge Thickness

Using Minus (-) or Plus (+) buttons adjust for 1 solid green and 1 blinking green light as shown.

### Harvest Time Adjustment

Using Minus (-) or Plus (+) buttons adjust for 4 solid green and 1 blinking green light. (5<sup>th</sup> light counting from left will blink when set properly)

### Freeze Mode Light

Freeze mode light in ON when unit is in a Freeze cycle.

### Timer ON

Timer ON light is ON when trigger point temperature is reached. Freeze will continue for an additional 7 minutes and then the machine will go into harvest.

Bridge Thickness and Harvest Settings should be adjusted by pressing either the Minus (-) or Plus (+) button one time, then checking ice at end of cycle.

 =Solid Light

 =Blinking Light

Note: Solid and Blinking Light Enlarged For Clarity.

### Ice Thickness Diagram



Ice Too Thin



Ice Just Right

1/8 Bridge



Ice Too Thick

### Ice Bridge Thickness Adjustment

Refer to the Ice Thickness Diagram for proper ice size.

Adjust by pushing the + sign or – sign on the ice bridge adjustment section of the control panel. If environmental conditions change, bridge thickness may need to be adjusted.

### Harvest Cycle Time Adjustment

After ice has formed in the inverted plate, it must be released so it can be deposited in the storage bin section. The harvest cycle is when that occurs, and must be long enough for the ice to release. While the harvest cycle length is self adjusting it can also be manually adjusted if needed.

If the harvest time is too short to release the ice, the time may be increased by pushing the + sign on the harvest time adjustment section of the control panel. Operate the machine for another cycle to confirm that the adjustment was correct. Note that too much harvest time will slightly decrease ice capacity.



### Bin Control Adjustment Settings.

When the machine is in the freeze mode, hold ice against the brass tube making sure that ice is touching at least 6 inches of the brass tube.

The machine should stop in approximately 1 minute. If the machine does not stop in the amount of time, rotate the adjustment screw **counterclockwise (warmer)** until it stops, then rotate the adjustment screw **clockwise (colder)** 1/8 (.125) of a turn.

If a minor adjustment is needed rotate the adjustment screw **clockwise (colder)** or **counterclockwise (warmer)**.

Note: The warmer the ambient, then the control should be adjusted **colder**.

The colder the ambient, then the control should be adjusted **warmer**.

**Initial Start Up**

1. Remove the front grill by removing the two screws located at the bottom holding it to the cabinet and pulling the panel down and off the machine.
2. Turn on the water supply, correct any leaks.

**Note: Water supply MUST be turned on first to allow water to enter the machine properly.**

3. Locate the On/Off/Wash master switch.
4. Move the switch to the ON position.
5. Ice bridge thickness and harvest time indicator lights will switch on. They will not change unless the cube size or harvest times are manually adjusted. The timer light will also be on.
6. The unit will fill the reservoir with water. The compressor and hot gas valve will be energized, but the fan motor and pump will be off. After 3 minutes the water will have filled the reservoir but will continue to fill and excess water will drain from the machine. This is normal and helps the machine from forming excessive mineral scale.
7. After 2 minutes, the water and hot gas valve will close and the pump and fan motor will start. A blue light in the control panel will glow indicating the beginning of the freeze cycle.
8. Warm air will begin to blow out the left front of the machine and water will spray up at the inverted ice making evaporator. It is normal for a small amount of water to drip from the ice making area. When the water temperature reaches a pre-set point the water pump may stop for about 30 seconds then resume. This will prevent slush in the water reservoir.

Freezing then continues for many minutes until the temperature of the refrigeration system drops to a set point, indicated by a yellow light glowing on the control panel. In colder rooms, the fan motor may turn on and off. After the yellow light switches on the freeze cycle continues for seven more minutes. At that time the unit changes to the ice release or harvest cycle. During ice harvest, the hot gas valve and inlet water valve are open, while the pump and fan motors will stop. During harvest, the yellow light should be on.

9. Within a minute or so the ice formed in the evaporator will fall down and slide into the ice storage bin. The ice will release as a group so all of the ice formed will fall at once and the next freeze cycle will begin in a few seconds. The blue light indicates freeze.
10. Check the thickness of the ice connecting the cubes to each other, that connection is known as a bridge and it should be about 1/8 inch or 3 to 4 mm thick. It is preset from the factory and should be satisfactory.

**Adjustments:**

If the ice bridge is too big or too small, the thickness may be adjusted.

**Note: The bridge thickness adjustment is used to obtain the CORRECT size, not to adjust to individual preferences. Do NOT make the ice bridge too thick or too thin, as either will reduce ice making capacity. Do NOT attempt to adjust the machine to release individual cubes. There is only ONE correct size.**

11. Ice making will continue until the ice level reaches the brass tube in the storage bin, when ice contacts that tube the machine will stop making ice within a minute. This can occur in any part of any cycle.
12. Removing ice from the ice storage bin will restart the ice making process. If the machine does not cycle on and off, please refer to the Service Manual for instructions on adjusting the bin control.
13. Check for and correct any water leaks from the unit or drain system.
14. Return the front grill to its normal position and secure it to the cabinet with the original screws.

**Typical Cycle Times (minutes)**

	70/50°F. (21/10°C.)	90/70°F. (32/21°C.)
CIU050	28-30	34-37
CIU070	16-18	23-26
CIU090	14-16	17-19

The time to fill a warm storage bin from empty varies by cabinet temperature and cycle time, but will take about 10-12 hours.

## **Use and Operational Notes**

To use, simply lift the door by its bottom edge and slide it up and into the top of the machine. Use the scoop to remove ice and close the door.

The machine will make the most ice if it has plenty of room to breathe. This is an air cooled product and it must be able to take in room air and discharge air heated by the ice making process. Blockage of vents or exposure to excessive heat will reduce the ice making and storage capacity. The storage bin is insulated but not refrigerated, so ice will melt during use. That is normal and assures that fresh ice is available in the bin.

The fan will make some noise during operation, however rattles and other vibrations are not normal and should be attended to. When the air temperature surrounding the machine is cold, the fan might cycle on and off during the freeze mode.

Minor adjustments may be made to compensate for local conditions by rotating the adjustment screw visible above the control area. If in a cold room, CW rotation changes the control to COLDER to fill the bin higher.

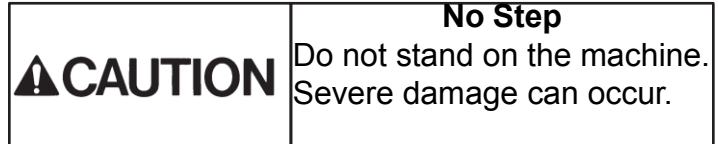

This appliance is not intended for use by persons (including children) with reduced physical, sensory or mental capabilities, or lack of experience and knowledge, unless they have been given supervision or instruction concerning use of the appliance by a person responsible for their safety.

Children should be supervised to ensure that they do not play with the appliance.

**Maintenance**

Regularly vacuum the right side of the air cooled condenser with a brush to remove all loose dust and dirt. Be careful not to damage the fins.

Cubed ice machines of this type make ice that is more pure than the water supplied to it. Since the ice has fewer impurities, the water that remains in the reservoir has more. The water system dilutes that concentration but eventually it does build up and need to be removed. Ice-O-Matic recommends cleaning machine every six (6) months, but local water conditions may require more frequent cleaning.

To remove scale from the water system.

Materials needed:

Ice-O-Matic Approved\*, nickel safe scale remover for ice machines, also known as ice machine cleaner.

- `Ice-O-Matic Approved\* Sanitizer
- Hand tools.
- Clean bucket
- Clean cloths
- Rubber or plastic gloves

1. Remove front grill.
2. Move master switch to Off, wait for 1 minute and then move it to On.
3. When the freeze cycle begins (blue light on), switch the machine to Off.
4. Remove and discard the ice from the bin.
5. Drain reservoir by pulling drain plug and return drain plug to its original position.

\*Refer to [www.iceomatic.com](http://www.iceomatic.com) for approved formulations

6. Mix a solution of 5 oz or 150 cc of ice machine Scale Remover and 2.5 quarts or 2.4 liters of clean, warm (95°F/35°C to 115°F./46°C) water.
7. Pour the solution into the reservoir by carefully adding it at the reservoir's front lip.
8. Move the master switch to the Wash position.
9. Wait 10 minutes.
10. Move the master switch to the Off position.
11. Drain the reservoir by removing drain plug and draining the solution into the bin. Return the drain plug to its normal position.
12. Remove spray platform by removing curtain and ice deflector. Confirm all jets are open. Rinse out any debris, reclose and return it as well as the deflector and curtain.
13. Pour 2.5 quarts or 2.4 liters of warm (95°F/35°C to 115°F./46°C) water into the reservoir by adding it at the reservoirs' front lip.
14. Switch the master switch to Wash for 1 minute, then switch it to Off.
15. Repeat step 11. Go to the next process to sanitize the machine.

Sanitize Water System – after completing prior scale removal and stopping at the end of its steps.

1. Mix a 1 gallon or 4 liter of warm (95°F/35°C to 115°F./46°C) water with EPA approved food equipment sanitizer following recommended mixture by sanitizer manufacturer.
2. Pour about half of the sanitizer mix into the reservoir.
3. Remove the curtain deflector and spray platforms. Wash them with the sanitizer, then return them to the ice machine.
4. Move the master switch to the Wash position.
5. Circulate the sanitizer for 2 minutes.
6. Move the master switch to Off.

	<p>Ice machine scale remover contains acids. Acids can cause burns.</p> <p>If concentrated cleaner comes in contact with skin, flush with water. If swallowed, do NOT induce vomiting. Give large amounts of water or milk. Call Physician immediately. Keep out of the reach of children.</p>
---	--

7. Drain the reservoir into the storage bin by removing the drain plug. Return the drain plug to its normal position.
8. Wash all interior surfaces of the ice machine storage bin, reservoir surface and inside of the door with the remaining sanitizer solution.
9. Pour any excess sanitizer down the ice machine bin drain.
10. Pour 2.5 quarts or 2.4 liters of warm (95°F/35°C to 115°F/46°C) water into the reservoir by adding it at the reservoirs' front lip.
11. Move the master switch to the Wash position for 1 minute, then switch it to Off.
12. Drain the reservoir by removing the drain plug and draining the solution into the bin. Return the drain plug to its normal position.
13. Move switch to the On position. The machine will resume normal ice making.
14. Return the front grill to its original position and secure it with the original screws.

**Before calling for service**

No ice – check water supply

No ice – check power supply. Remove front grill, if there are no lights on the control panel there is no power to the controller.

No ice – check temperature of cabinet. If too cold the machine will not operate.

Slow production – check condenser for dirt, clean condenser.

Slow production – check temperature of cabinet, if the room is hot or air flow restricted, production will be slow.

Ice is poorly formed. Check spray. If some spray jets are restricted, ice will be poorly formed. Clean water system to correct.



Wiring Diagram-115 Volt

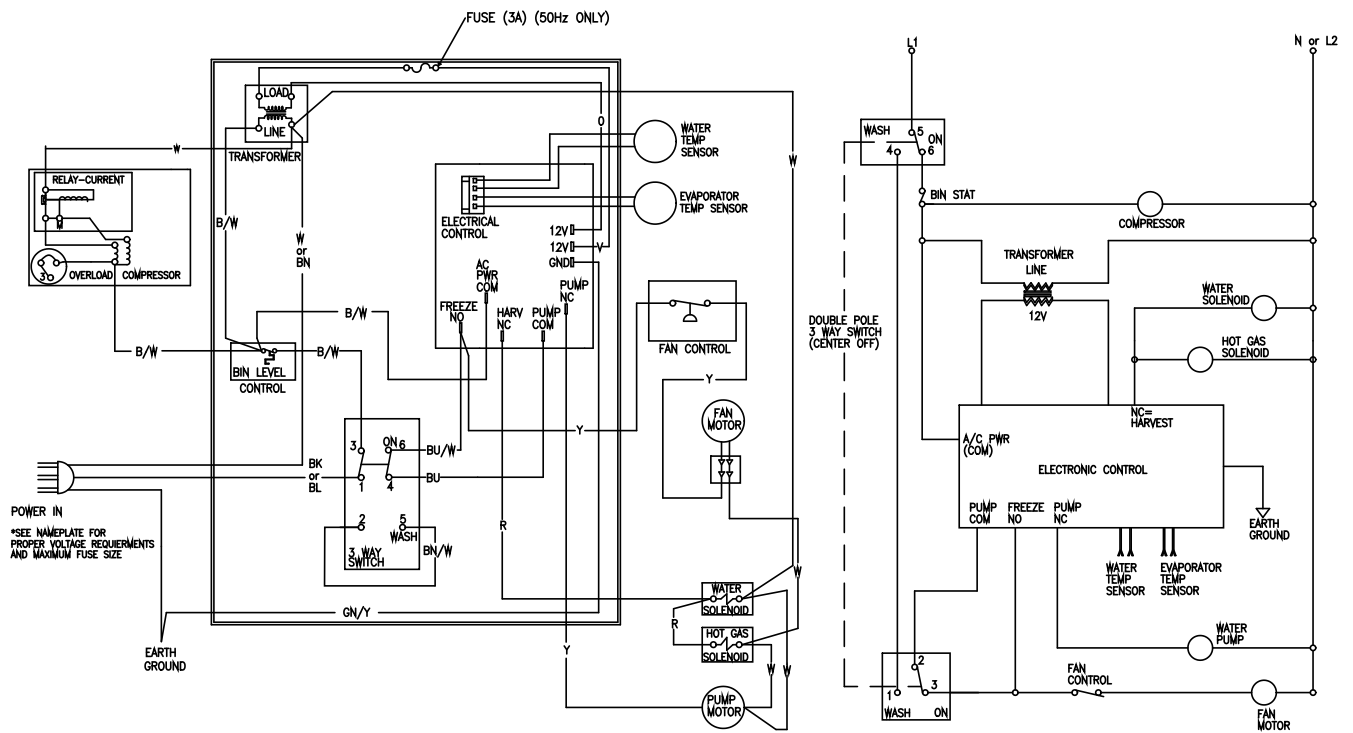

POWER IN  
\*SEE NAMEPLATE FOR  
PROPER VOLTAGE REQUIREMENTS  
AND MAXIMUM FUSE SIZE

CAUTION:  
MORE THAN ONE DISCONNECT MEANS MAY BE  
REQUIRED TO DISCONNECT ALL POWER TO UNIT

THIS UNIT MUST  
BE GROUNDED

SWITCHES ON THIS UNIT  
SHOWN IN FREEZE CYCLE

9072183-01 REV A