

C30 Air and Water

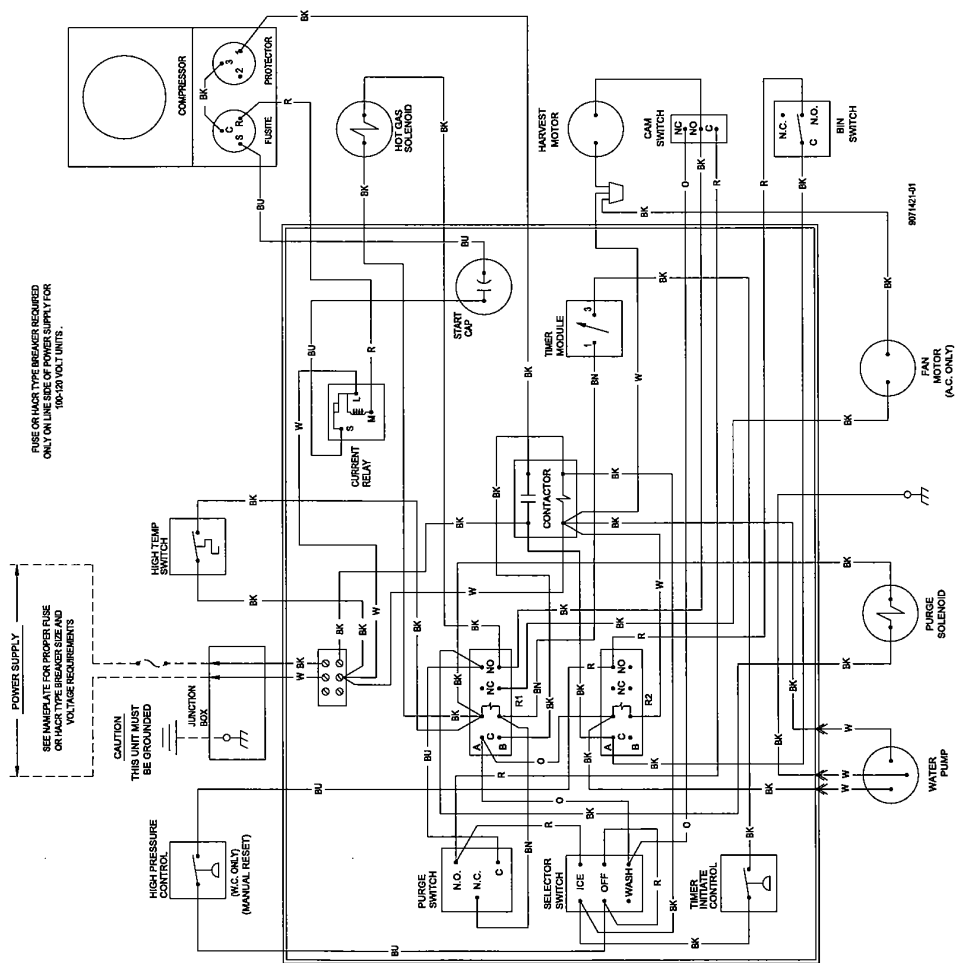

WIRING SCHEMATIC  
AIR & WATER  
(SHOWN IN TIMED PORTION FREEZE CYCLE)

