



SERVICE PARTS MANUAL
22 INCH WIDE ICE SERIES CUBERS
MODEL-ICE0320A1,A2,W1,W2 ICE0520A1,A2,W1,W2
Includes 50Hz. Units



14-1004

Date 1/18/17

ICE0320/0520 Service Parts

This parts list contains the service parts available for the ICE0320/0520 icemakers.

Check the model number on the data plate and refer to the correct listing for the specific component.

Check carefully that the correct part is identified and ordered.

Table of Contents	Page 1
Cabinet Exterior	Page 2
ICE0320 Air Cooled	Page 3
ICE0520 Air Cooled	Page 4
Water Cooled	Page 5
ICE0320 Evaporator	Page 6
ICE0520 Evaporator	Page 7
ICE0320 Air Condenser Components	Page 8
ICE0520 Air Condenser Components	Page 9
Water Cooled Condenser Components	Page 10
Water Pump/Float	Page 11
Control Box	Page 12
Harvest Assist Assembly	Page 13
Specific Compressor Components	Page 14

Parts indicated NLA=No Longer Available, No Replacement Unless Indicated.

**Ice-O-Matic
11100 East 45th Ave.
Denver Co. 80239**

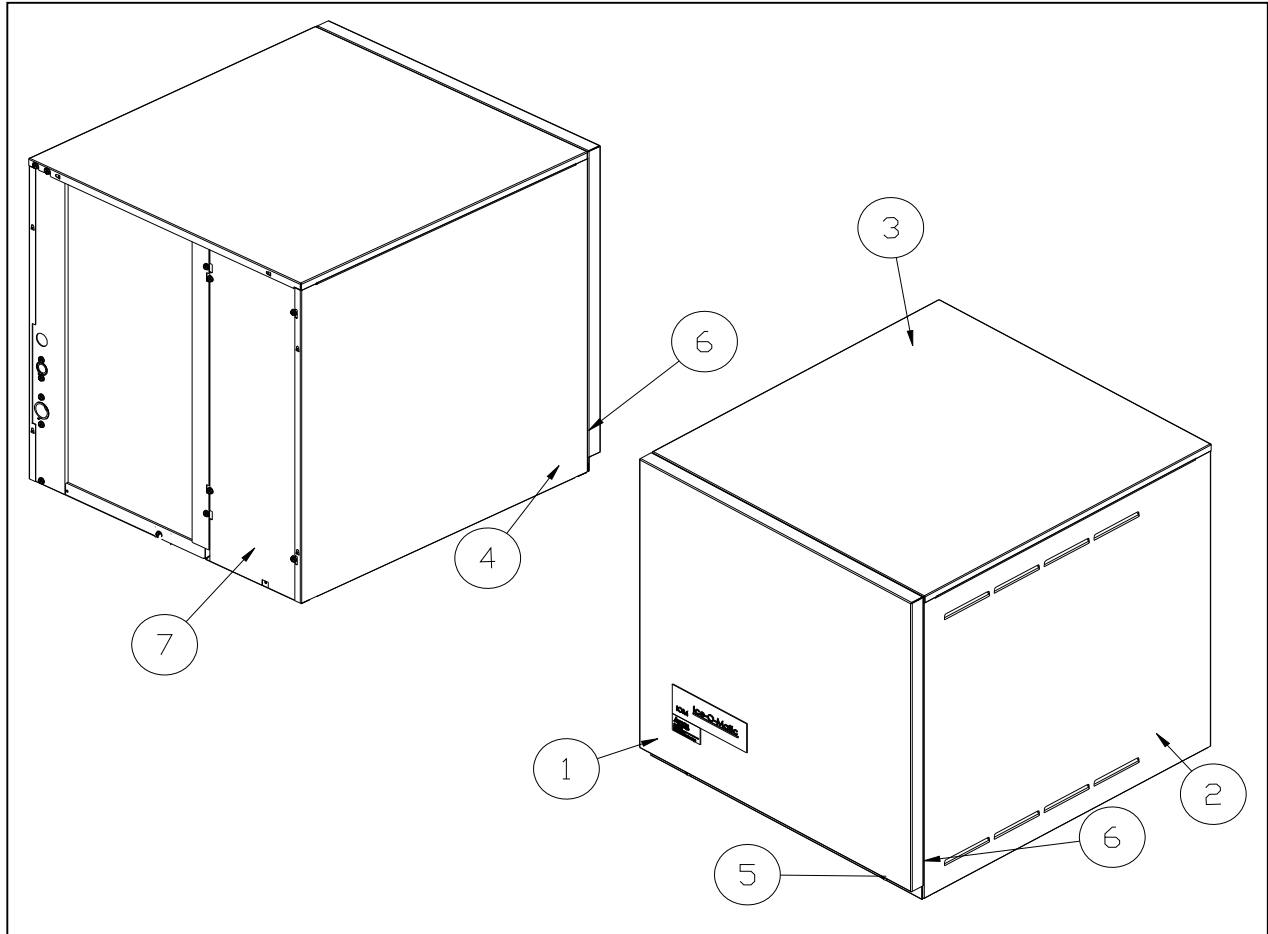

Item No.	Description	Part Number	
1	Front Panel	2031490-01S	
2	Right Hand Side Panel	3021831-01	Air Cooled Only
2	Right Hand Side Panel	3021862-01	Water Cooled Only
3	Top Panel	3021847-01	
4	Left Hand Side Panel	2101330-01S	
5	Front Panel Screw	9031098-03P	
6	Side Panel Screw	9031046-01P	
7	Rear Cover Panel	3021838-01	Air Cooled Only
	Plastic Nut	9031141-01P	

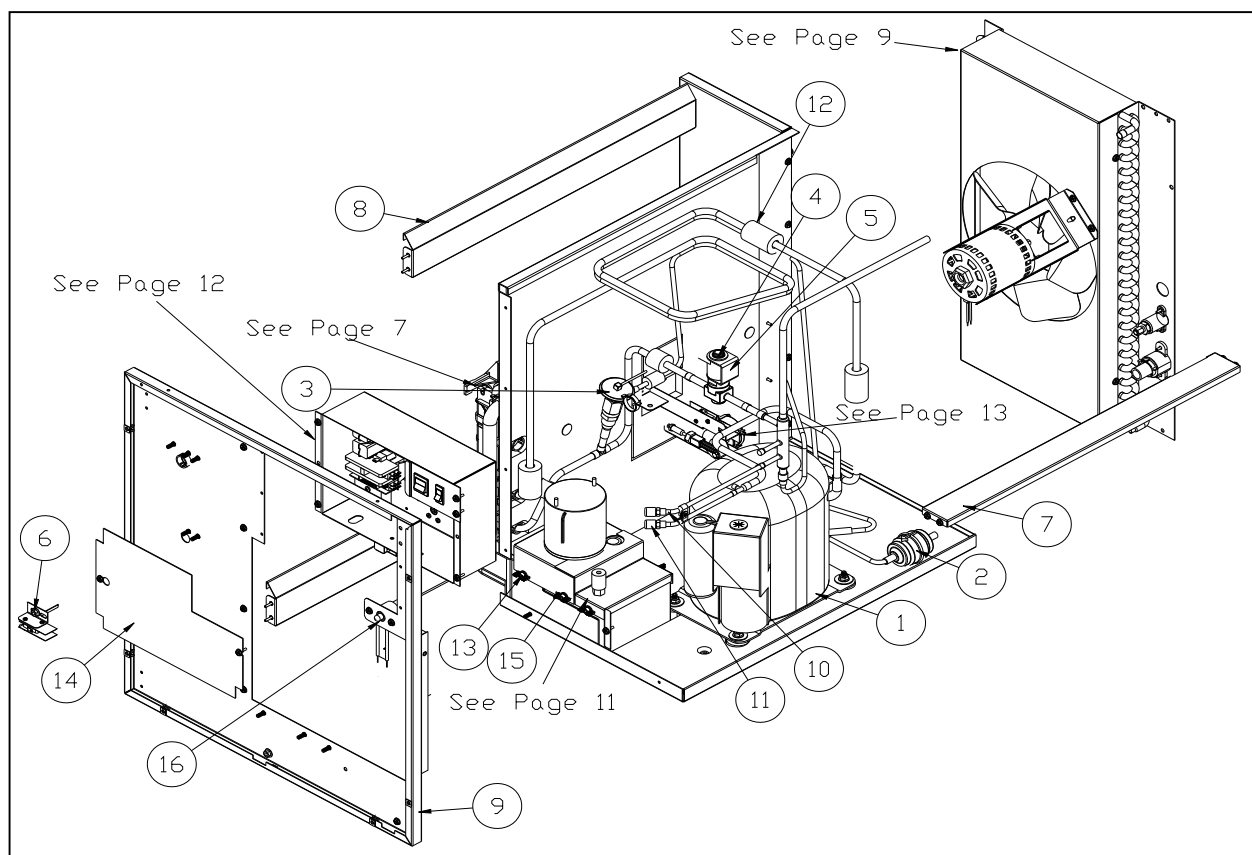

Item No.	Description	Part Number	
1	Compressor Kit	9181121-11	ICE0320
1	Compressor Kit	9181122-11	ICE0325
2	Filter-Drier (9051004-02 is NLA)	9151163-01	
3	Expansion Valve NLA-NR	9151006-21	ICE0320A
3	Expansion Valve	9151154-101**	ICE0320A Beginning Ser. Mid D2
3	Expansion Valve	9151154-101**	ICE0325
4	Hot Gas Valve Body	9151123-01	
5	Hot Gas Valve Coil 115V	9151123-03	ICE0320
5	Hot Gas Valve Coil 230V	9151123-04	ICE0325
6	Bin Switch NLA-NR	3051230-01S	ICE0320, 0325, 0520 and 0525
6	Bin Switch and Bracket	2061471-03S	ICE0320 and 0325 Beg. Ser. D422-00305-Z
	Bin Switch Only	9101124-02	ICE0320 and 0325 Beg. Ser. D422-00305-Z
7	Side Brace	3012965-01	
8	Ice Deflector	3012924-01	
9	Front Panel NLA	2021577-01	
10	Service Valve Core	9091086-02	
11	Service Valve Cap	9091086-03	
12	High Temp Safety	9041087-03	
13	Nylon Wing Nut	9031161-01	
14	Control Box Cover	3012974-01	
15	Water Pan	9051478-01	
16	High Pressure Control	9041051-04	
	Wtr Pan Screw (3 Req'd)	9031046-24P	

**Note 9151134-04 is NLA, Replaced by 9151154-101

NLA-NR=No Longer Available-No Replacement

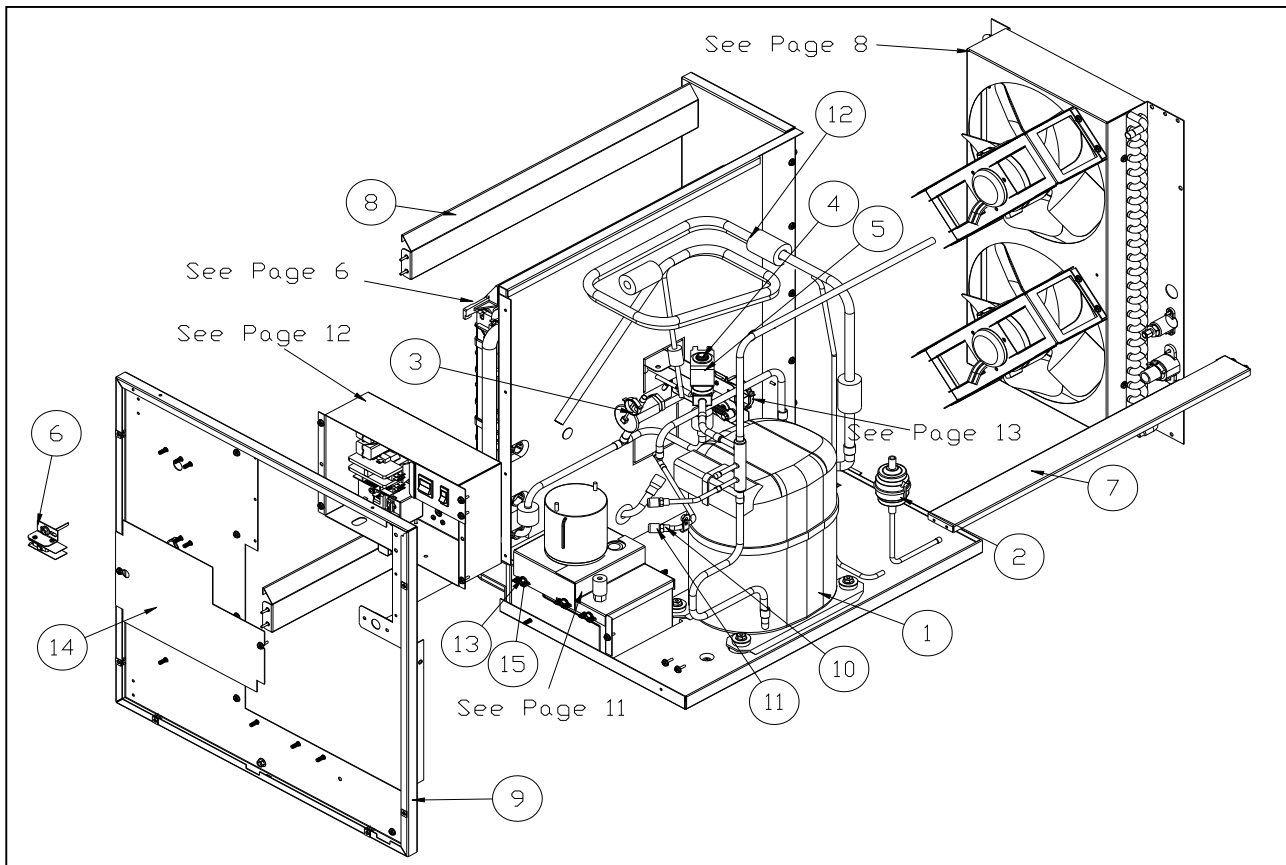

Item No.	Description	Part Number	
1	Compressor Kit NLA-NR	9181086-11	ICE0520
1	Compressor Kit NLA-NR	9181116-11	ICE0525
2	Filter-Drier (9151004-02 is NLA)	9151163-01	
3	Expansion Valve	9151006-08	ICE0520
3	Expansion Valve	9151149-101*	ICE0520 Beginning Ser. A2
3	Expansion Valve	9151149-101*	ICE0525
4	Hot Gas Valve Body	9151123-01	
5	Hot Gas Valve Coil 115V	9151123-03	ICE0520
5	Hot Gas Valve Coil 230V	9151123-04	ICE0525
6	Bin Switch	3051230-01	
6	Bin Switch and Bracket	2061471-03S	ICE0520 and 0525 Beg. Ser. D423-00320-Z
	Bin Switch Only	9101124-02	ICE0320 and 0325 Beg. Ser. D422-00305-Z
7	Side Brace	3012965-01	
8	Ice Deflector	3012924-01	
9	Front Panel NLA	2021577-01	
10	Service Valve Core	9091086-02	
11	Service Valve Cap	9091086-03	
12	High Temp Safety	9041087-03	
13	Nylon Wing Nut	9031161-01	
14	Control Box Cover	3012974-01	
15	Water Pan	9051478-01	
	Wtr Pan Screw (3 Req'd)	9031046-24P	

*Note 9151134-01 is NLA, Replaced by 9151149-101
NLA-NR=No Longer Available-No Replacement

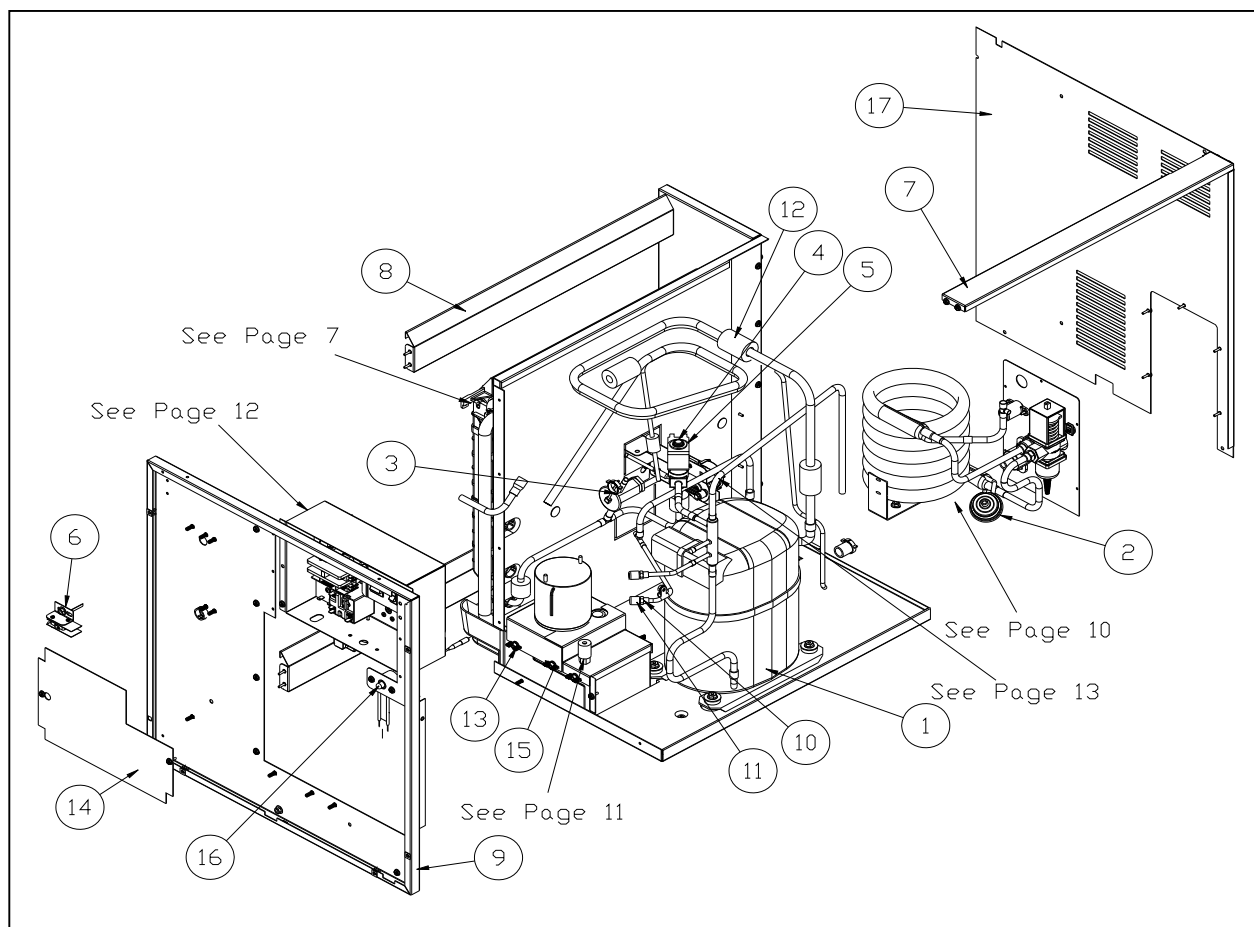

Item No.	Description	Part Number	
1	Compressor Kit	9181121-11	ICE0320
1	Compressor Kit NLA	9181086-11	ICE0520
2	Filter-Drier (9151004-02 is NLA)	9151163-01	
3	Expansion Valve NLA	9151006-21	ICE0320
3	Expansion Valve	9151149-101*	ICE0520
4	Hot Gas Valve Body	9151123-01	
5	Hot Gas Valve Coil 115V	9151123-03	
6	Bin Switch	3051230-01	
6	Bin Switch	2061471-03S	ICE0320 and 0325 Beg. Ser. D422-00305-Z
6	Bin Switch and Bracket	2061471-03S	ICE0520 and 0525 Beg. Ser. D423-00320-Z
	Bin Switch Only	9101124-02	
7	Side Brace	3012965-01	
8	Ice Deflector	3012924-01	
9	Front Panel NLA	2021577-01	
10	Service Valve Core	9091086-02	
11	Service Valve Cap	9091086-03	
12	High Temp Safety	9041087-03	
13	Nylon Wing Nut	9031161-01	
14	Control Box Cover	3012974-01	
15	Water Pan	9051478-01	
16	High Pressure Control	9041051-04	
17	Rear Panel	3021863-01	

*Note 9151134-01 is NLA, Replaced by 9151149-101

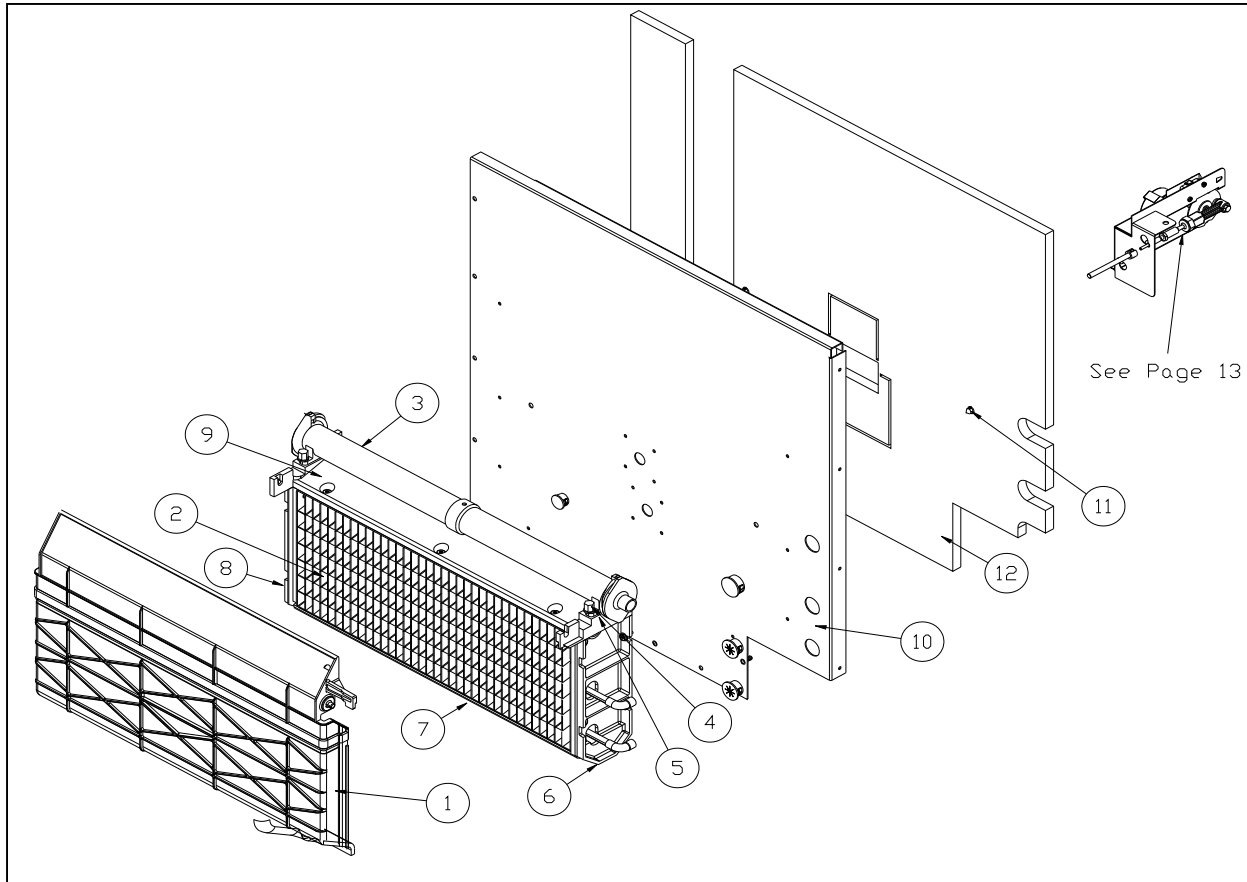

Item No.	Description	Part Number
1	Splash Curtain	3051233-02
2	Evaporator-Half	2051222-02S
2	Evaporator-Full	2051222-01S
3	Water Dist. Tube	2041338-02
4	Thumb Screw	9031122-01
5	Rubber washer	9031004-19
6	Evap Side Panel RH	9051136-08
7	Water Return	9051135-04
8	Evap Side Panel LH	9051136-07
9	Spillway	9051135-05
10	Center Panel	2021601-01
11	Insulation Clip	9031154-01
12	Insulation	9131413-01

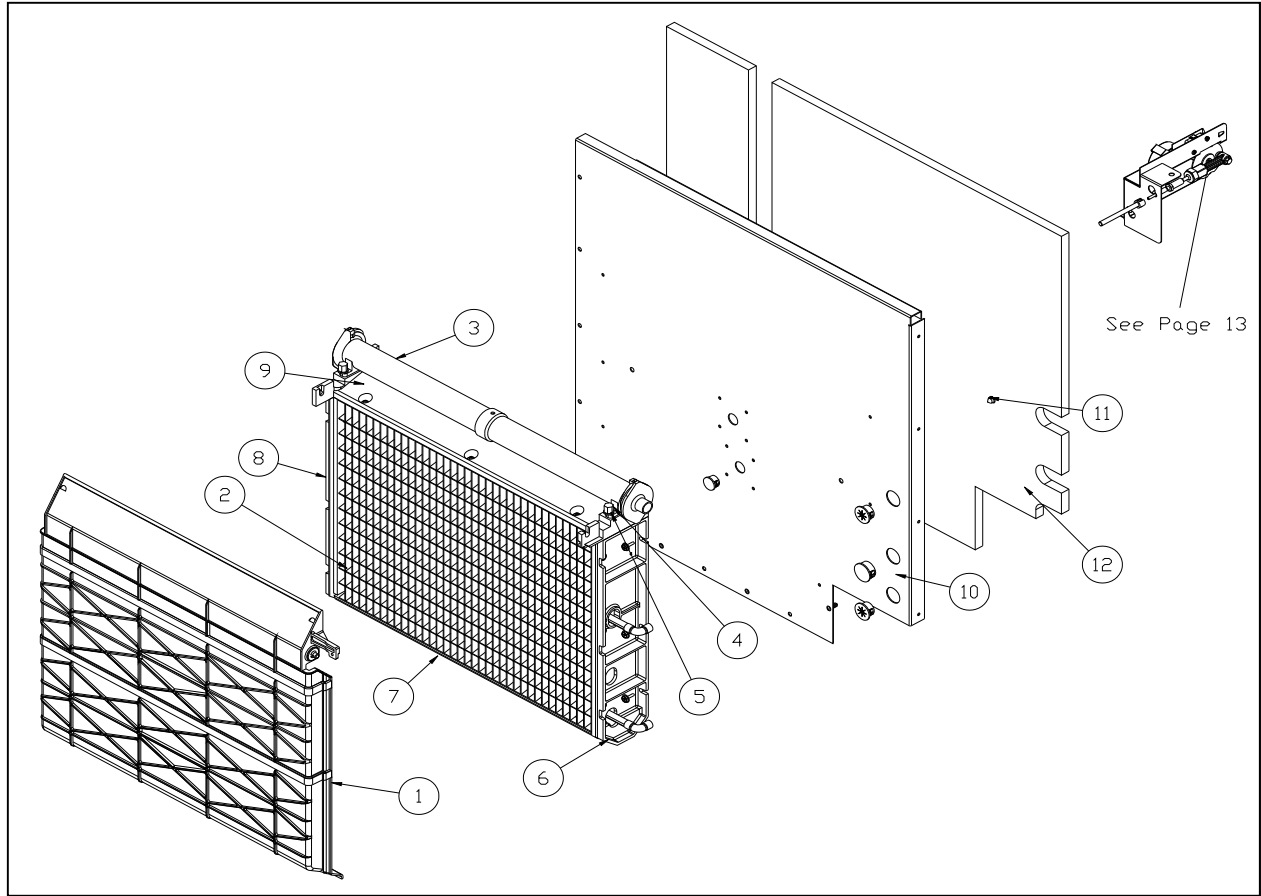

Item No.	Description	Part Number
1	Splash Curtain	2101355-04S
2	Evaporator-Half NLA-NR	2051147-82
2	Evaporator-Full NLA-NR	2051147-81
3	Water Dist. Tube	2041338-02
4	Thumb Screw	9031122-01
5	Rubber washer	9031004-19
6	Evap Side Panel RH	9151136-06
7	Water Return	9051135-04
8	Evap Side Panel LH	9051136-05
9	Spillway	9051135-05
10	Center Panel	2021601-01
11	Insulation Clip	9031154-01
12	Insulation	9131413-01

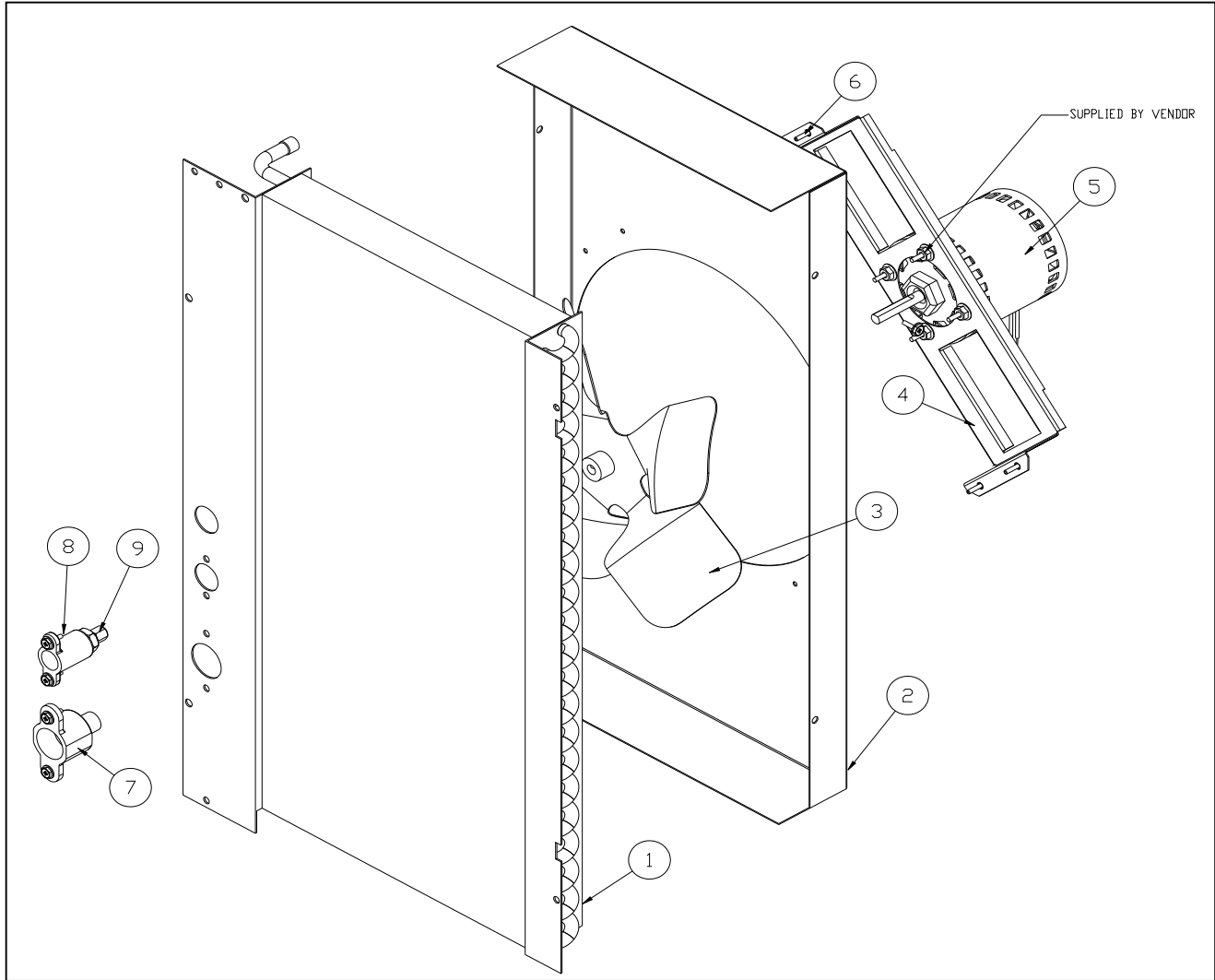

Item No.	Description	Part Number	
1	Air Condenser	9141118-01	
2	Fan Shroud	3013111-01	
3	Fan Blade	9131225-01	ICE0320
3	Fan Blade	9131384-04	ICE0325
4	Fan Motor Bracket	3013059-01	ICE0320
4	Fan Motor Bracket	2021612-01	ICE0325
5	Fan Motor 115V	1051209-04*	ICE0320
5	Fan Motor 230V	9161124-02	ICE0325
6	#10-16X1/2 Screw	9031046-01	
7	Drain Fitting	9091140-01	
8	Drop Adapter	9091074-01	
9	Water Inlet Fitting	9091083-01	

9161089-02 is NLA
9161078-02 is NLA

*Note 1051209-04 include Fan Motor, Blade and Bracket

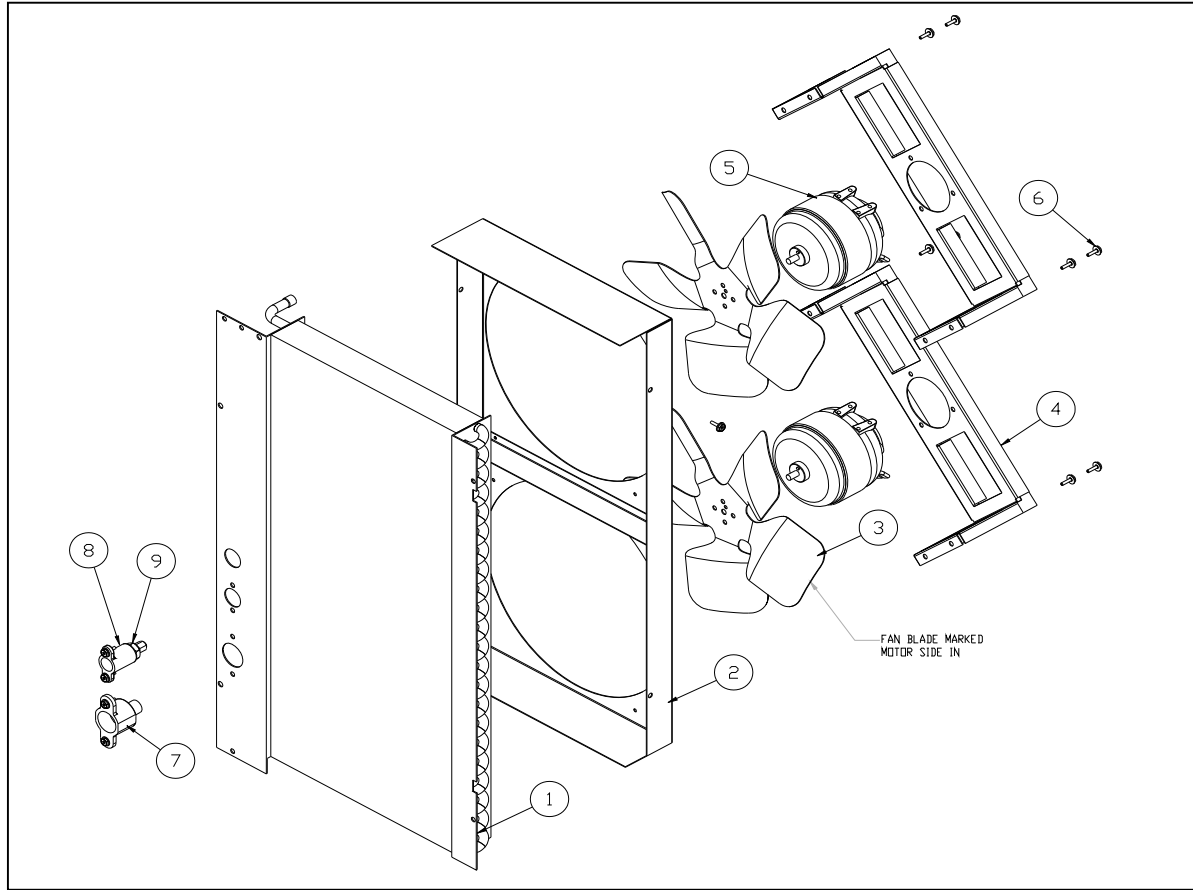

Item No.	Description	ICE 0520	ICE 0525
1	Air Condenser (Z)	9141117-01	9141117-01
1	Air Condenser Beg. Ser. A2	9141118-01	9141118-01
2	Fan Shroud	2021613-01	2021613-01
3	Fan Blade	9131225-01	9131225-01
3	Fan Blade Beg. Ser A2	9131384-04	
4	Fan Motor Bracket	3013059-01	3013059-01
4	Fan Motor Bracket Beg. Ser. A2	2021612-01	
5	Fan Motor 115V*	9161112-01	
5	Fan Motor 115V Beg. Ser. A2	9161112-01	
5	Fan Motor 230V		9161124-02
6	#10-16X1/2 Screw	9031046-01	9031046-01
7	Drain Fitting	9091140-01	9091140-01
8	Drop Adapter	9091074-01	9091074-01
9	Water Inlet Fitting	9091083-01	9091083-01

9161108-01* is NLA

9161078-02 is NLA

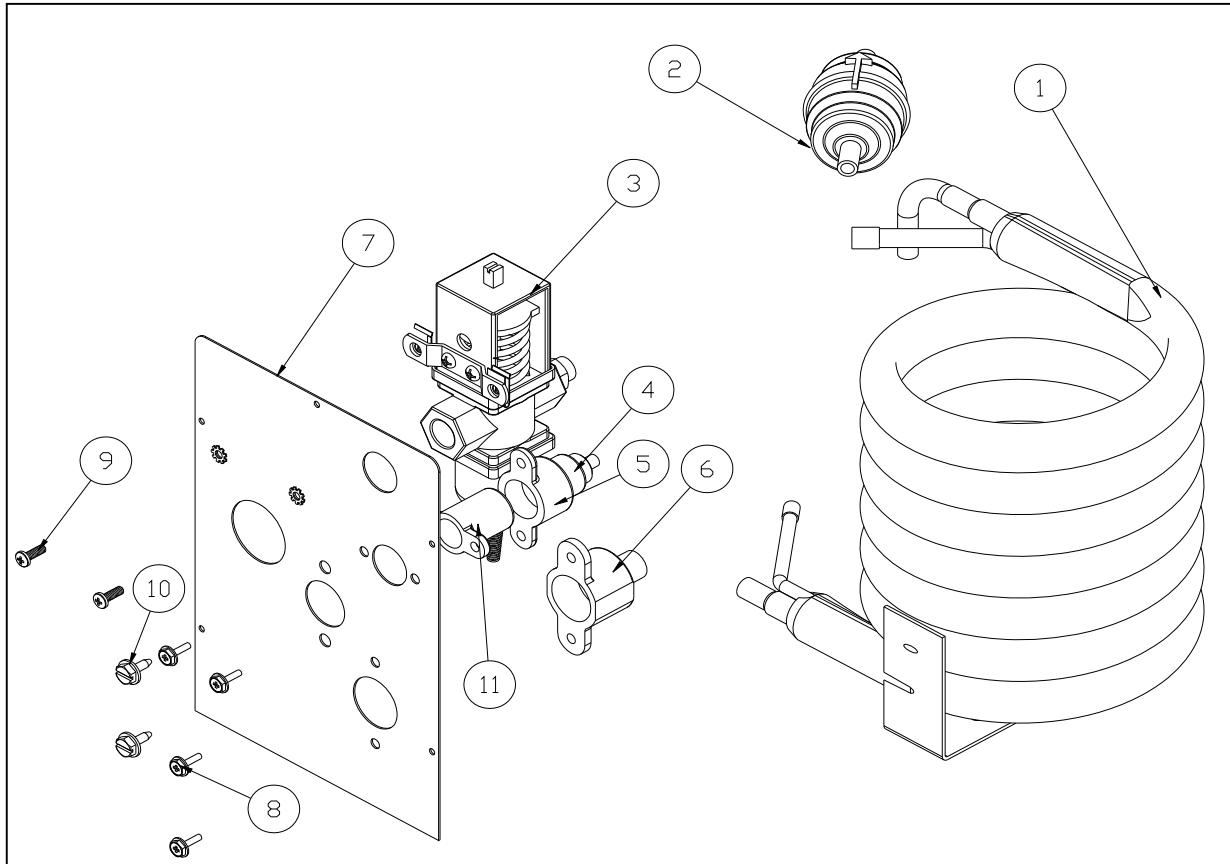

Item No.	Description	Part Number
1	Water Condenser (9141119-01 is NLA)	9141121-01
2	Filter-Drier (9151004-02 is NLA)	9151163-01
3	Water Regulator	9041059-01
4	Reducer Fitting	9091014-09
5	Drop Adapter	9091063-02
6	Drain Fitting	9091140-01
7	Bracket	3013079-01
8	#10-16 X 1/2 Screw	9031046-01
9	Pan Head Screw	9031008-07
10	1/4-20 X 1/2 Screw	9031019-04
11	Drop Adapter	9091074-01

Minor modifications may be required.

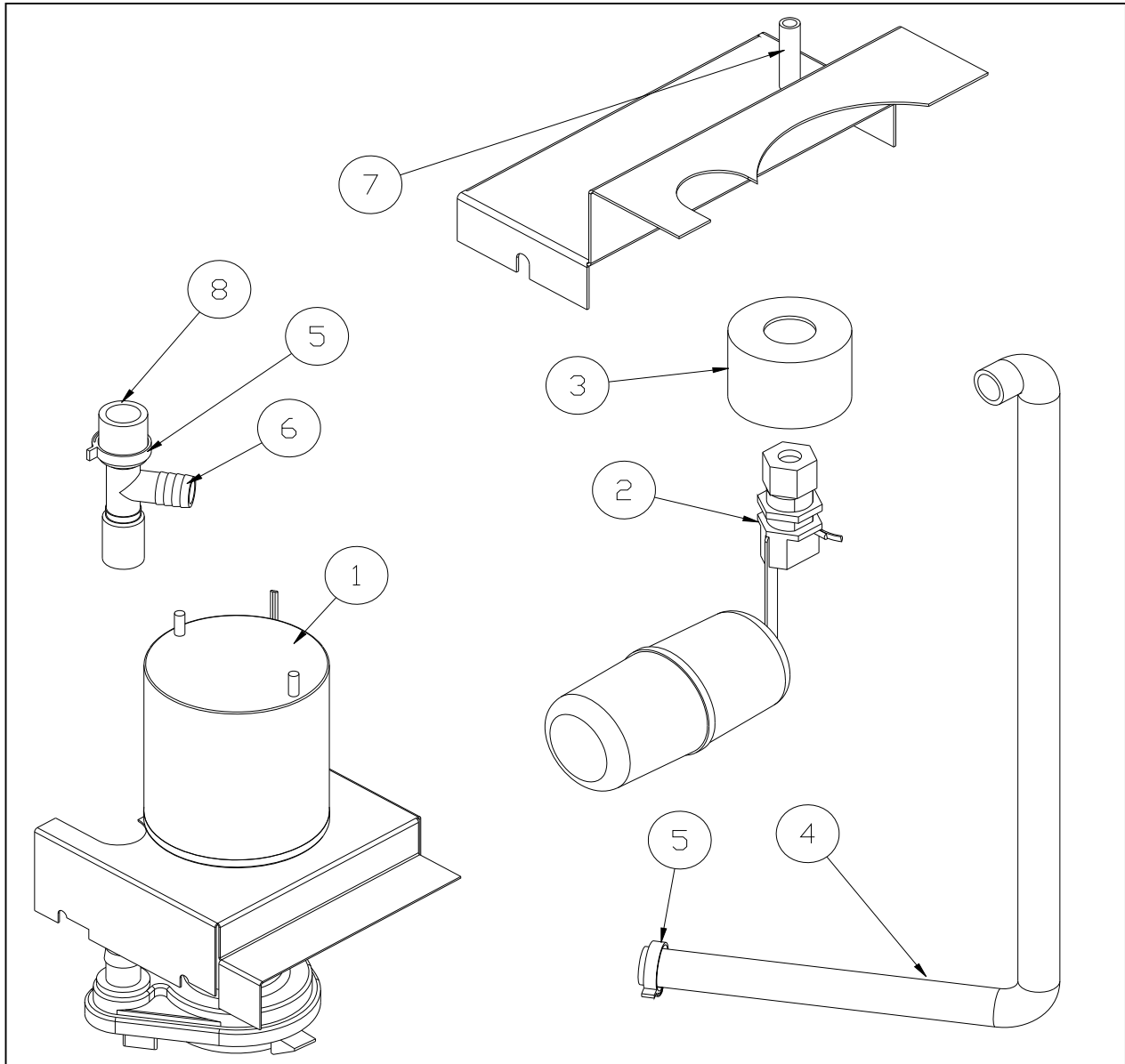

Item No.	Description	Part Number	
1	Water Pump 115V	9161076-01	ICE0320
1	Water Pump 230V	9151076-02	ICE0325
1	Water Pump 115V	9161076-01	ICE0520
1	Water Pump 230V	9161079-03	ICE0525
	Thumbscrew for Pump (2 Req)	9161076-101	
2	Float Assembly (Includes Fittings)	9131111-101	9131111-01 is NLA
3	Splash Shield	9131026-02	
4	Water Tube, Evap	9051506-02	ICE0320/ 0325
4	Water Tube, Evap	9051506-01	ICE0520/ 0525
5	Plastic Clamp	9021010-04	
6	Barbed Tee	9091024-01	
7	1/4" Tube 24.00" Lg	3032898-24	
8	5/8" ID X 10" Tube	3051223-10	

Please note: Thumbscrews are shipped with the Water Pump when ordered as a service replacement part.

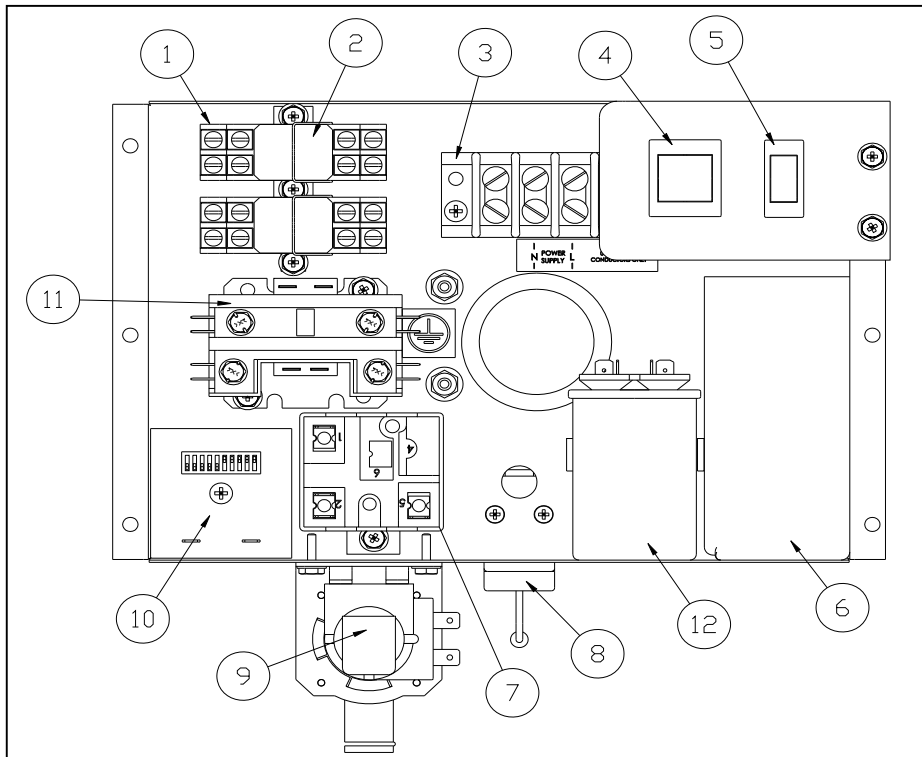

Item No.	Description	Part Number	
1	Relay Socket	9101083-01	
2	Relay 115 Volt	9101084-01	ICE0320/0520
2	Relay 230 Volt	9101084-02	ICE0325/0525
3	Terminal Board	9101037-01	
4	On-Off Wash Switch	9101195-01	9101349-01 is NLA
5	Purge Switch	9101139-03	1051208-01 is NLA
6	Start Capacitor	9181003-39	ICE0320
6	Start Capacitor (Z)	9181003-17	ICE0520
6	Start Capacitor	9181003-40	ICE0325
6	Start Capacitor (Z)	9181003-04	ICE0525
7	Current relay	9181004-27	ICE0320
7	Potential Relay	9181010-14	ICE0520
7	Potential Relay (Z)	9181010-26	ICE0325
7	Potential Relay	9181010-04	ICE0525
8	Low Pressure Con	9041094-01 is NLA	
		9041104-101A	
9	Purge Valve 115V	9041086-04 is NLA	ICE0320/520
9	Purge Valve 230V	9041086-05 is NLA	ICE0325/525
10	Timer	9101148-01	
11	Contactor 115V	9101002-07	ICE0320/520
11	Contactor 230V	9101002-06	ICE0325/525
12	Run Capacitor	9181009-08	ICE0325
12	Run Capacitor (Z)	9181009-09	ICE0525
	High Temp Safety	9041087-03	
	High Pressure Control	9041051-04	
	Water Pump Cord	9101218-11	

Reference the Model Numbers below for the specific Harvest Assist Assembly

Description	Model Number			
	ICE0320	ICE0325	ICE0520	ICE0525
Complete Assembly	1051210-01A	1051210-02A	1051210-01A	1051210-02A
No Longer Available	2061962-01S	2061962-02S	2061962-01S	2061962-02S



1051210-XX Reference above for Specific Model Number and Part Number

- The **1051210-XX** assembly will fit all ICE Models from October 1999 and EC Models.
- Units installed with a double cam switch, either Field installed or Factory installed will require the complete assembly and a potential wiring change as per the New Wiring Diagram included with the assembly.
- Individual component parts are not available for the **1051210-XX** assembly.
- Individual component parts are No Longer Available for previous version of the Harvest Assist Assembly
- Parts for the **2061962-XX** Harvest Assist Assembly are not compatible with **1051210-XX** Harvest Assist Assembly.
- Proper assembly and alignment of the parts is critical to proper operation, this includes cam and probe alignment.
- If a **1051210-XX** assembly fails, it must be returned to Ice-O-Matic.

1051210-XX are only supplied as complete assemblies, individual components are not available.

Please reference the above Model Numbers to insure the correct assembly is supplied

THE DUAL CAM SWITCH HARVEST ASSIST ASSEMBLIES ARE NO LONGER AVAILABLE

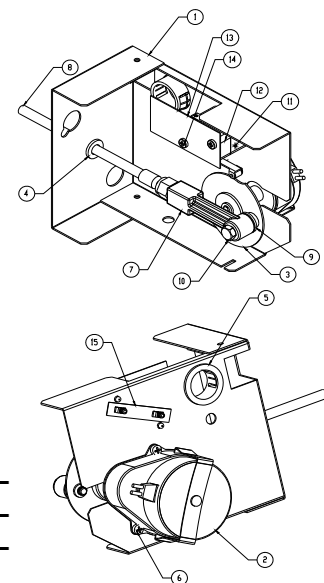
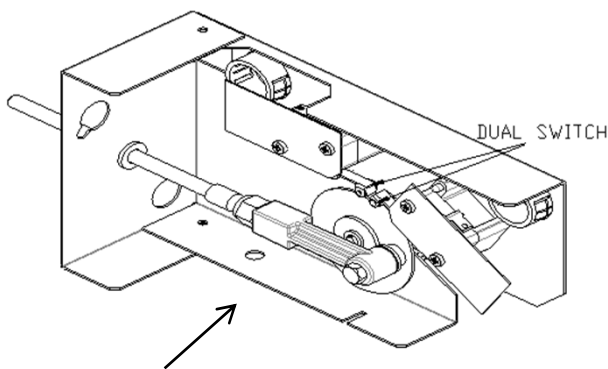

1051199-01	No Longer Available	
1051200-01	No Longer Available	
1051201-01	No Longer Available	
1051202-01	No Longer Available	2061962-01S No Longer Available
1051207-01	No Longer Available	2061962-02S No Longer Available

ICE0520 Air and Water Cooled

Compressor Kit	9181121-11
Start Capacitor	9181003-39
Relay	9181004-27
Overload	9181005-37
Drier 9151004-02 is NLA	9151163-01

ICE0325 Air Cooled

Compressor Kit	9181122-11
Start Capacitor	9181003-40
Run Capacitor	9181009-08
Relay (Z)	9181010-26
Overload	9181005-39
Drier 9151004-02 is NLA	9151163-01

ICE0520 Air and Water Cooled

Compressor Kit	9161086-11
Start Capacitor (Z)	9181003-17
Relay	9181010-14
Overload	9181005-12
Drier 9151004-02 is NLA	9151163-01

No Longer Available-No Replacement**ICE0525 Air Cooled**

Compressor Kit	9181116-11
Start Capacitor	9181003-04
Run Capacitor	9181009-09
Relay	9181010-04
Overload NLA	9181005-36
Drier 9151004-02 is NLA	9151163-01

No Longer Available-No Replacement

Compressor Kits include Driers and all Start Components