

11.0 C-SERIES CUBERS: C61-C81-C121-C146-C186 "C" SERIES AIR, WATER AND REMOTE  
(SINGLE DIGIT LED)

Item Code	Part Description	Part Number	GRP	C	C	C	C	C
				61	81	121	146	186
<b>AIR COOLED</b>								
5	Air Condenser	NLA	AC				X	
5	Air Condenser	NLA	AC		X	X		
5	Air Condenser - (After 5/91)	NLA	AC	X				
5	Air Condenser - (Before 5/91)	NLA	AC	X				
10	Fan Blade 10" 30 degree	9131053-01	AC		X	X	X	
10	Fan Blade 10" 36 degree	9131053-03	AC	X				
11	Fan Control	9041003-01	AC		X			
11	Fan Control	9041003-02	AC	X		X		
15	Fan Motor 16 watt	9161045-04	AC		X	X		
15	Fan Motor 35 watt	9161078-03	AC				X	
15	Fan Motor 35 watt C61	9161078-01	AC	X				
20	Fan Motor Bracket	9131054-01	AC	X	X	X	X	
25	Fan Shroud	9131131-01	AC	X	X	X	X	
30	Fan Shroud - Push Rivet	NLA	AC	X	X	X	X	
<b>COMPRESSOR AND COMPONENTS (*Kit Includes Drier and Start Components)</b>								
100	*Compressor Kit - COPE CRE2-0225-PFV	NLA	C			X		
100	*Compressor Kit- COPE RSN4-0075-CAV	NLA	C	X				
100	*Compressor Kit - COPE	NLA	C				X	
100	*Compressor Kit - COPE 3 PH CRJ3-0300-TF5	NLA	C				X	
100	Compressor-TECU 3PH (C124)	NLA	C			X		
100	*Compressor Kit - COPE CRKE-0325-PFV	NLA	C					X
100	*Compressor Kit - COPE 3 PH CRKE-0325-TF5	NLA	C					X
100	Compressor-TECU 3PH (C84)	NLA	C		X			
100	Compressor-TECU	NLA	C			X		
100	Compressor-TECU	NLA	C		X			
101	Overload - COPE 071-0329-16	NLA	C	X				
105	Run Capacitor	9181009-12	C		X	X		
105	Run Capacitor	9181009-08	C	X				
105	Run Capacitor (COPE)	9181009-12	C			X		
105	Run Capacitor	9181009-13	C					X
105	Run Capacitor	9181009-14	C				X	
110	Start Capacitor	9181003-08	C	X				
110	Start Capacitor	NLA	C		X	X		
110	Start Capacitor (COPE)	9181003-19	C			X		
110	Start Capacitor	9181003-21	C				X	X
115	Start Relay	9181010-04	C	X			X	
115	Start Relay	9181010-06	C		X	X		
115	Start Relay (COPE)	9181010-10	C			X		
115	Start Relay	9181010-11	C					X
<b>ELECTRICAL</b>								
205	Bin Control Thermostat (Stacked) 3 Pole	9041055-01	E	X	X	X	X	X
210	Contactator - 1 Pole 115V	9101002-03	E	X	X	X		
210	Contactator - 1 Pole 230V	9101002-04	E				X	X
210	Contactator - 3 Pole 115V	NLA	E		X	X		
210	Contactator - 3 Pole 230 V	9101079-02	E				X	X
215	Terminal Block - 3 Position	9101037-01	E				X	
215	Terminal Block - 6 Position	NLA	E			X		
215	Terminal Block - 5 Position	9101037-03	E		X			
215	Terminal Block - 4 Position	9101037-02	E		X	X	X	X
216	Terminal Board - 2 Position (Board Common)	NLA	E	X	X	X	X	X
235	Switch Assy-Bin Control (Curtain) RIGHT SIDE	NLA	E	X	X	X		
236	Switch Assy-Bin Control (Curtain) LEFT SIDE	2061471-01	E		X	X		

11.0 C-SERIES CUBERS: C61-C81-C121-C146-C186 "C" SERIES AIR, WATER AND REMOTE  
(SINGLE DIGIT LED)

Item Code	Part Description	Part Number	GRP	C	C	C	C	C
				61	81	121	146	186
<b>ELECTRICAL (Continued)</b>								
240	Switch-Bin Control Limit (Curtain)	9101145-02	E				X	X
240	Switch-Bin Control Limit (Curtain)	NLA	E	X	X	X		
245	Switch - On/Off/Wash	9101138-01	E			X		
250	Switch - Purge	9101139-02	E				X	X
270	Evaporator Thermostat Kit	1051088-01	E	X	X	X	X	X
270	Condenser Thermistor (@32F=31K-34K OHMS)	9101150-06	E	X	X	X	X	X
272	Controller Board 230V(Ref Serv. Bulltin #0798)	NLA	E				X	X
272	Controller Board 115V(Ref Serv. Bulltin #0798)	NLA	E	X	X	X		
280	Controller Board - Stand Off	NLA	E	X	X	X	X	X
285	Controller Board - Wiring Harness	NLA	E	X	X	X		
285	Controller Board - Wiring Harness	NLA	E				X	X
290	Controller Board-Indicator Light (Front Panel)	NLA	E	X	X	X	X	X
291	Controller Board - Indicator Lampholder	NLA	E	X	X	X	X	X
<b>EVAPORATOR</b>								
300	Evaporator Plastic Bottom - Water Return	9051135-04	EV	X	X	X	X	X
305	Evaporator Plastic Side Panel LH	9051170-04	EV					X
305	Evaporator Plastic Side Panel LH	9051136-05	EV	X	X	X	X	
310	Evaporator Plastic Side Panel RH	9051136-06	EV	X	X	X	X	
310	Evaporator Plastic Side Panel RH	9051170-03	EV					X
315	Evaporator Plastic Top - Spillway	9051135-05	EV	X	X	X	X	X
320	Evaporator Plate Assy - Full Cube LH	2051148-81	EV	X	X	X	X	
320	Evaporator Plate Assy - Full Cube LH	2051125-81	EV					X
320	Evaporator Plate Assy - Full Cube RH	2051147-81	EV		X	X	X	
320	Evaporator Plate Assy - Full Cube RH	2051126-81	EV					X
320	Evaporator Plate Assy - Half Cube LH	2051148-82	EV	X	X	X	X	
320	Evaporator Plate Assy - Half Cube LH	2051125-82	EV					X
320	Evaporator Plate Assy - Half Cube RH	2051147-82	EV		X	X	X	
320	Evaporator Plate Assy - Half Cube RH	2051126-82	EV					X
320	Evaporator Plate Assy - Jumbo LH	NLA	EV	X	X	X	X	
320	Evaporator Plate Assy - Jumbo RH	NLA	EV		X	X	X	
<b>HARVEST ASSIST ASSEMBLY</b>								
900	Bushing - Large	9051001-13	HA	X			X	X
900	Bushing - Small	NLA	HA	X	X	X		
905	Clutch (Cam) 10 Degree	9131190-02	HA	X	X	X	X	X
910	Connecting Rod	9051057-01	HA	X	X	X	X	X
915	Drip Shield (FOR 2061620-01-02)	NLA	HA	X	X	X	X	X
920	Harvest Motor Assy w/.219 S/S 115V	2061962-08	HA	X	X	X		
920	Harvest Motor Assy w/.219 S/S 230V	2061962-09	HA				X	X
925	Hex Nut 10 x 32 (Swivel/Shaft)	9031005-03	HA	X	X	X	X	X
925	Hex Nut (SWIVEL/PLASTIC TIP SHAFT)	NLA	HA	X	X	X	X	X
930	Hex Nut #4 (Switch)	NLA	HA	X	X	X	X	X
930	Speed Nut (Switch)	9031120-01	HA	X	X	X	X	X
935	Probe Motor 230V	9161031-01	HA				X	X
935	Probe Motor 115V	9161030-01	HA	X	X	X		
940	Probe Shaft 4.5 x .125 (PLASTIC TIP)	9021053-02	HA	X	X	X		
940	Probe Shaft 4.5 x .219 Stainless Steel	9131189-01	HA	X	X	X	X	X
945	Screw Shoulder - Rod/Clutch	9031119-01	HA	X	X	X	X	X
950	Screw #4 - 40 x 3/4 (Switch)	9031008-16	HA	X	X	X	X	X
955	Screw #6 - 32 x 1/2 (Motor)	9031019-08	HA	X	X	X	X	X
960	Switch Insulator (Micro)	3051145-01	HA	X	X	X	X	X
965	Switch - Cam (Micro)	9101160-02	HA	X	X	X	X	X
970	Swivel for 9021053-02 (PLASTIC TIP SHAFT)	9021017-01	HA	X	X	X	X	X

11.0 C-SERIES CUBERS: C61-C81-C121-C146-C186 "C" SERIES AIR, WATER AND REMOTE  
(SINGLE DIGIT LED)

Item Code	Part Description	Part Number	GRP	C	C	C	C	C
				61	81	121	146	186
<b>HARVEST ASSIST ASSEMBLY (Continued)</b>								
970	Swivel for 9131189-01	9021017-02	HA	X	X	X	X	X
975	Washer - Flat #10, Stainless	9031003-03	HA	X	X	X	X	X
<b>MISCELLANEOUS</b>								
	Water Trough Guard	NLA	M	X				
	Water Trough Clip	3012545-01	M	X				
405	Hose Clamp #14	9021010-03	M	X	X	X	X	X
410	Hose Clamp #18	9021010-04	M	X	X	X	X	X
420	Ice Deflector Kit With Out Thermo-well	1051026-01	M	X				
420	Ice Deflector Kit With Out Thermo-well	1051026-02	M		X	X	X	X
425	Ice Deflector Kit With Thermo-well	1051026-04	M		X	X	X	X
425	Ice Deflector Kit With Thermo-well	1051026-03	M	X				
430	Ice Deflector-Inner	3011756-01	M		X	X	X	X
430	Ice Deflector-Inner	NLA	M	X				
435	Screw Retainer (Rubber Washer Under Screw)	9031004-19	M	X	X	X	X	X
440	Screw - Water Trough	9031122-02	M	X	X	X	X	X
445	Screw - Water Tube Assy	9031122-01	M	X	X	X	X	X
<b>PANELS</b>								
	Paint Grey Touch-up (Spray Can)	NLA	P	X	X	X	X	X
	Paint Beige Touch-up (Spray Can)	NLA	P	X	X	X	X	X
502	Control Box Cover, Grey	NLA	P					X
506	Front Panel, Stainless Steel	NLA	P		X	X	X	X
506	Front Panel, Stainless Steel	2031335-02	P	X				
510	J-Clip	NLA	P	X	X	X	X	X
516	Rear Panel	NLA	P	X				
516	Rear Panel	NLA	P				X	
516	Rear Panel	3021570-01	P					X
516	Rear Panel	NLA	P		X	X		
520	Screw #8 - 18 x 1-1/2	NLA	P	X	X	X	X	X
522	Screw #8 - 18 x 3/8, Stainless	NLA	P	X	X	X	X	X
522	Screw #8 - 18 x 3/8,	NLA	P	X	X	X	X	X
528	Side Panel, Stainless	NLA	P					X
528	Side Panel LH Stainless Steel	3021562-02	P		X	X	X	
530	Side Panel RH Stainless Steel	3021559-02	P		X	X	X	
536	Top Panel, Stainless Steel	3021432-01	P		X	X	X	
536	Top Panel, Stainless Steel	3021433-01	P	X				
536	Top Panel, Stainless Steel	NLA	P					X
589	Front Lower Panel Assy, Stainless	2031337-01	P					X
<b>REFRIGERATION</b>								
600	Expansion Valve Tube Assembly*	2041548-01	REF					X
601	Check Valve	NLA	REF		X	X	X	
605	Distributor (Refrigerant)	9151061-01	REF					X
610	Expansion Valve - Flared	9151006-01	REF	X		X		
610	Expansion Valve - Sweat	9151006-06	REF				X	
610	Expansion Valve	9151020-01	REF		X			
610	Expansion Valve	NLA	REF					X
615	Drier Receiver	9151033-01	REF	X	X	X		
615	Filter Drier	9151004-02	REF	X				
615	Filter Drier	9151004-04	REF		X	X		
615	Filter Drier	9151004-03	REF				X	X
625	Hot Gas Valve Assy - PARKER 230V	9151090-01	REF				X	X
625	Hot Gas Valve Body - ALCO	9151123-01	REF	X				
630	Hot Gas Valve Coil - ALCO 115V	9151123-03	REF	X	X	X		

11.0 C-SERIES CUBERS: C61-C81-C121-C146-C186 "C" SERIES AIR, WATER AND REMOTE  
(SINGLE DIGIT LED)

Item Code	Part Description	Part Number	GRP	C	C	C	C	C
				61	81	121	146	186
<b>REFRIGERATION (Continued)</b>								
630	Hot Gas Valve Coil - PARKER 230V	9151091-92	REF				X	X
640	Service Valve Assy	2101160-01	REF	X	X	X	X	X
645	Service Valve Core	9091086-02	REF	X	X	X	X	X
650	Service Valve Cap	9091086-03	REF	X	X	X	X	X
*Includes Brazed Expansion Valve, Distributor And Tubing Assembly								
<b>REMOTE</b>								
700	Accumulator Assembly	2091147-01	REM				X	
700	Accumulator Assembly	NLA	REM					X
705	Contactora - 2 Pole Remote	NLA	REM	X	X	X		
705	Contactora - 2 Pole Remote	9101015-04	REM				X	X
710	Filter Drier - Remote	9151004-04	REM	X	X	X		
710	Filter Drier - Remote	9151004-03	REM				X	X
715	Liquid Line Valve Body - ALCO	9151123-02	REM	X	X	X		
720	Liquid Line Valve Coil - ALCO 230V	9151123-04	REM				X	X
720	Liquid Line Valve Coil - ALCO 115V	9151123-03	REM	X	X	X		
725	Mixing Valve (Headmaster) (125 PSI)	9151027-04	REM		X			
725	Mixing Valve (Headmaster) (192 PSI)	9151027-02	REM	X		X	X	X
730	Pump Down Control	9041072-01	REM				X	X
730	Pump Down Control	NLA	REM	X	X	X		
735	Receiver - EARLY-FLARED	9151026-01	REM	X				
735	Receiver - LATE-SWEAT	9151074-01	REM	X				
735	Receiver - Sweat	9151060-01	REM		X	X	X	
735	Receiver (Before 10/91)	NLA	REM					X
735	Receiver (After 10/91)	9151079-01	REM					X
737	High Pressure Control (250 PSI)	NLA	REM		X			
737	High Pressure Control (400 PSI)	9041051-02	REM	X		X	X	X
<b>REMOTE CONDENSER</b>								
740	Coupling Half Bulkhead 1/2	9091001-12	RC	X	X	X	X	X
745	Coupling Half Bulkhead 3/8	9091001-11	RC	X	X	X	X	X
750	Coupling Half Lineset 1/2	9091001-08	RC	X	X	X	X	X
755	Coupling Half Lineset 1/2 W/Port	9091001-10	RC	X	X	X	X	X
760	Coupling Half Lineset 3/8	9091001-02	RC	X	X	X	X	X
765	Coupling Half Lineset 3/8 W/Port	9091001-04	RC	X	X	X	X	X
766	Coupling Half Mounting Flange 3/8	9091001-03	RC	X	X	X	X	X
767	Coupling Half Mounting Flange 1/2	9091001-09	RC	X	X	X	X	X
770	Fan Motor (LARKIN ONLY)	1011179-99	RC				X	X
781	Kit-Fan Motor Upgrade (MTR, BRKT, BLADE)	NLA	RC			X		
781	Kit-Fan Motor Upgrade (MTR, BRKT, BLADE)	NLA	RC				X	
781	Kit-Fan Motor Upgrade (MTR, BRKT, BLADE)	NLA	RC	X	X	X		
781	Kit-Fan Motor Upgrade (MTR, BRKT, BLADE)	NLA	RC				X	
781	Kit-Fan Motor Upgrade (MTR, BRKT, BLADE)	NLA	RC					X
782	Fan Support (In Kit)	NLA	RC	X	X	X	X	X
783	Fan Blade (In Kit-RC-120-2-20" Dia)	9131214-01	RC			X	X	
783	Fan Blade (In Kit-18" Dia)	NLA	RC	X	X	X	X	X
784	Fan Motor (In Kit-230V)	NLA	RC				X	X
784	Fan Motor (In Kit-115V)	9161087-01	RC	X	X	X		
<b>WATER COOLED</b>								
790	Water Condenser	9141020-01	WC			X		
790	Water Condenser	9141024-01	WC	X	X			
790	Water Condenser	NLA	WC					X
790	Water Condenser	NLA	WC				X	
792	High Pressure Control (250 PSI)	NLA	WC		X			

11.0 C-SERIES CUBERS: C61-C81-C121-C146-C186 "C" SERIES AIR, WATER AND REMOTE  
(SINGLE DIGIT LED)

Item Code	Part Description	Part Number	GRP	C 61	C 81	C 121	C 146	C 186
<b>WATER COOLED (Continued)</b>								
792	High Pressure Control (400 PSI)	9041051-02	WC	X		X	X	X
795	Water Regulator Valve	9041056-01	WC					X
795	Water Regulator Valve	9041010-01	WC	X	X	X	X	
<b>WATER DISTRIBUTION</b>								
800	Water Distribution Tube LH	2041338-02	WD		X	X	X	X
805	Water Distribution Tube RH	2041338-01	WD	X	X	X	X	X
810	Water Inlet Polyethylene Tube	6021032-01	WD					X
815	Water Pump Tube	NLA	WD				X	
815	Water Pump Tube	NLA	WD					X
815	Water Pump Tube	NLA	WD		X	X		
815	Water Pump Tube	9051142-02	WD	X				
820	Water Splash Curtain	9051154-08	WD	X	X	X	X	
820	Water Splash Curtain	9051154-12	WD					X
820	Water Splash Curtain LH, (Snap-on Ear)	NLA	WD					X
820	Water Splash Curtain RH, (Snap-on Ear)	NLA	WD					X
825	Water Trough	9051201-01	WD					X
825	Water Trough	9051537-01	WD	X				
825	Water Trough	9051153-07	WD		X	X	X	
<b>WATER FLOAT</b>								
	Water Float Gasket (9131180-01)	9051204-01	WF	X				
845	Water Float Assy	9131111-01	WF		X	X	X	X
845	Water Float Assy (SIDE FLOAT)	9131180-01	WF	X				
850	Water Float Deflector (9131111-01)	9131026-02	WF		X	X	X	X
<b>WATER PUMP</b>								
855	Purge Valve Cover, Stainless	NLA	WP				X	X
865	Water Pump Bracket, Stainless	NLA	WP		X	X		
865	Water Pump Bracket, Stainless	NLA	WP				X	X
875	Water Pump	9161076-01	WP	X				
875	Water Pump	9161079-01	WP		X	X		
875	Water Pump	9161079-02	WP				X	X
<b>WATER PURGE VALVE</b>								
880	Water Purge Valve Assy 115V	9041053-01	WPV	X				
880	Water Purge Valve Assy	9041014-07	WPV				X	X
880	Water Purge Valve Assy 115V	NLA	WPV		X	X		
890	Water Purge Valve Coil	9041014-91	WPV				X	X
890	Water Purge Valve Coil - 115V	9041014-90	WPV	X	X	X		

REFRIGERANT CHARGE		
MODEL	REF TYPE	OZ.
C61A	R502	28
C61W	R502	18
C61R	R502	144
C81A	R12	44
C81W	R12	30
C81R	R12	208
C121A	R502	50
C121W	R502	32
C121R	R502	208
C146A	R502	108
C146W	R502	30
C146R	R502	240
C186W	R502	48
C186R	R502	400

PRESSURES	
DP	HP
225	400
	400
125	250
	250
225	400
225	400
225	400
225	400
225	400

C61C

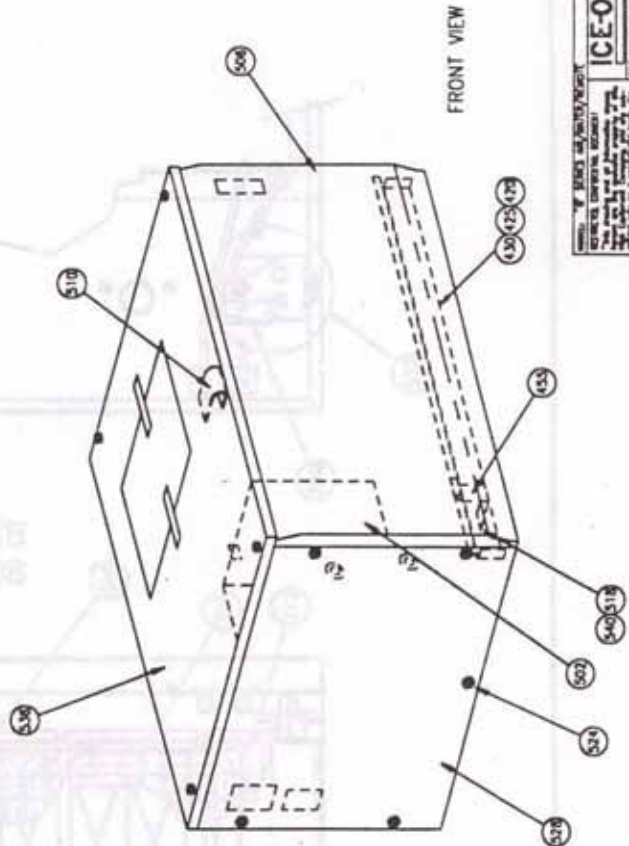
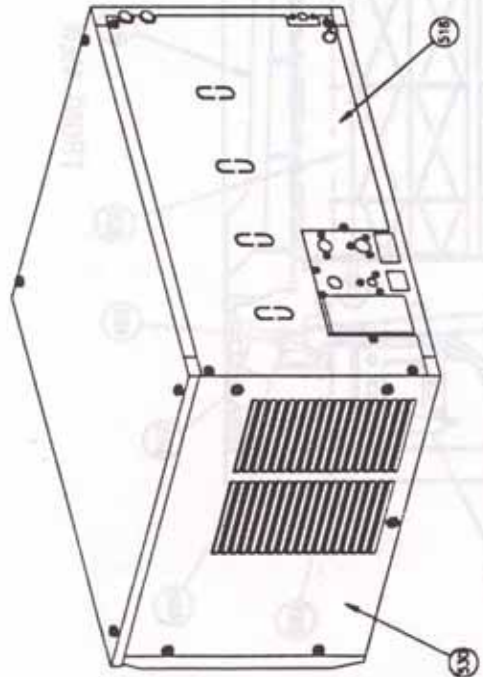

ICE-O-MATIC  
PANEL ASSEMBLY



C61C

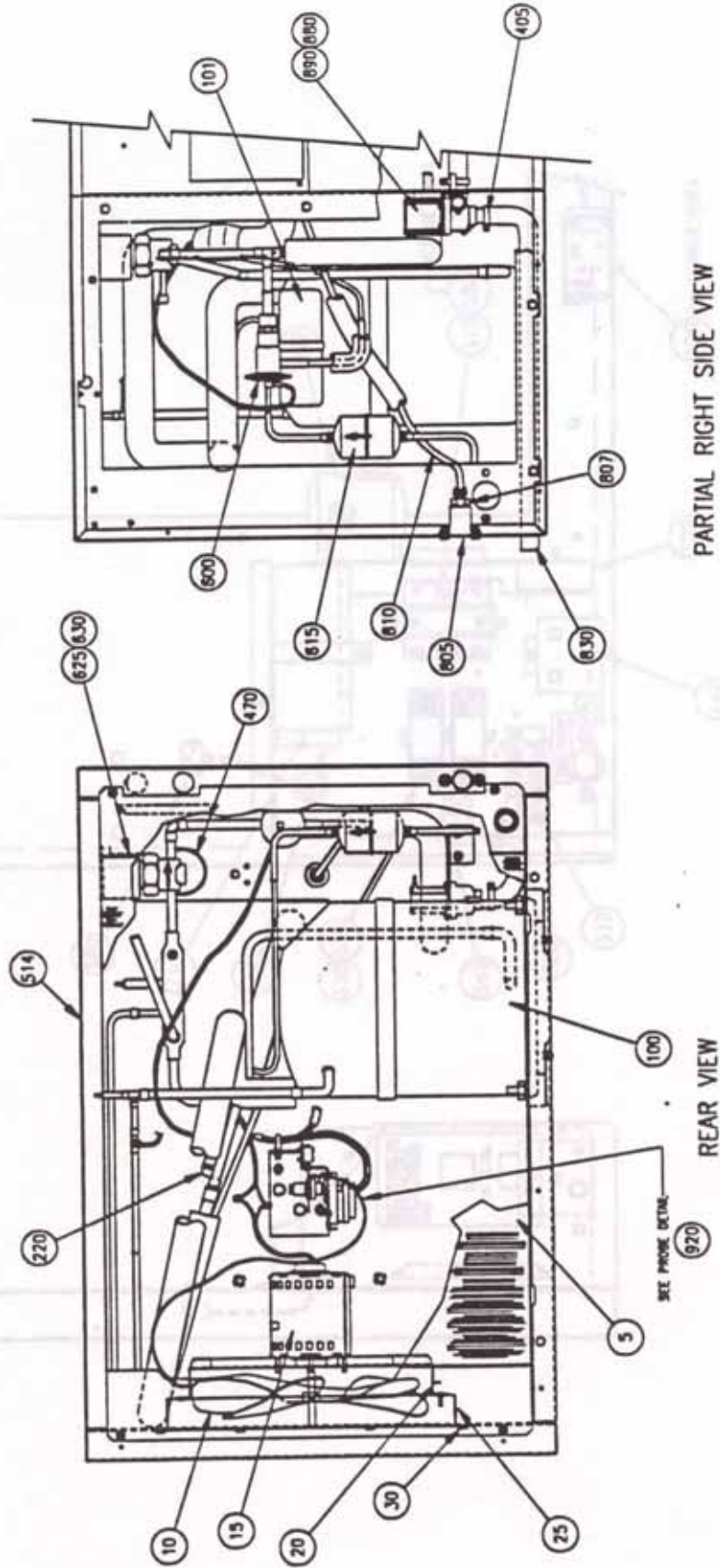



C61C

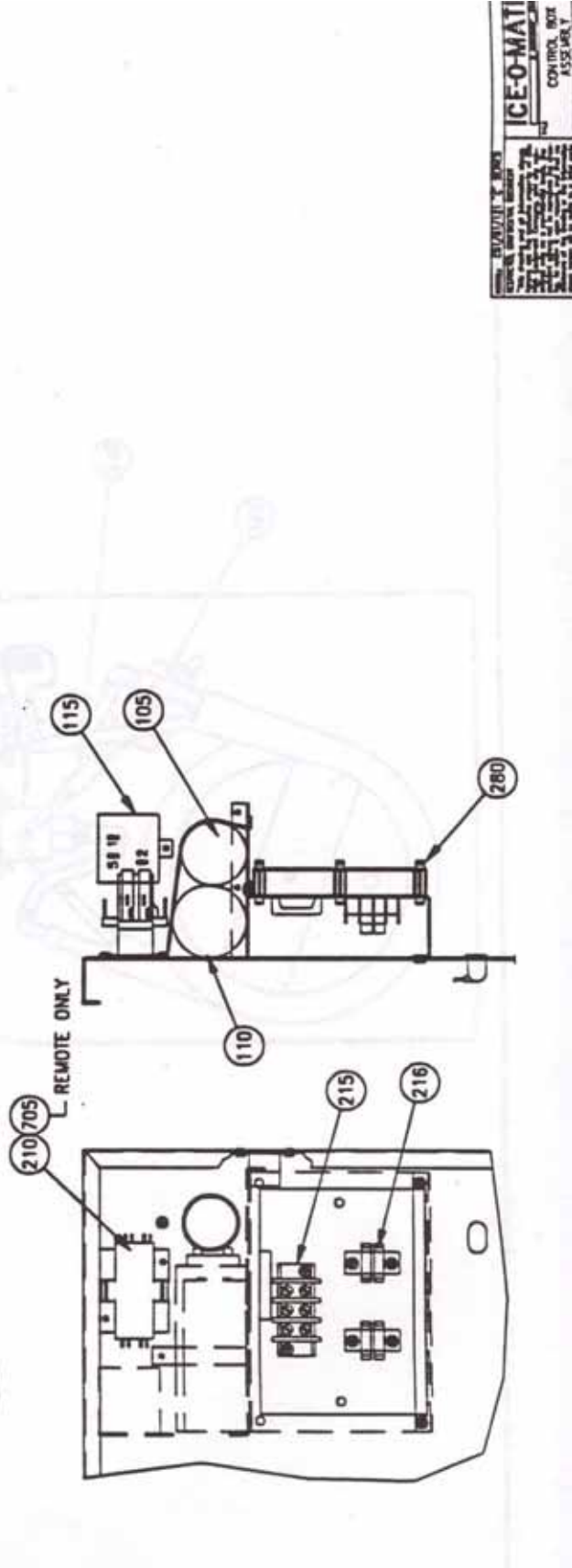
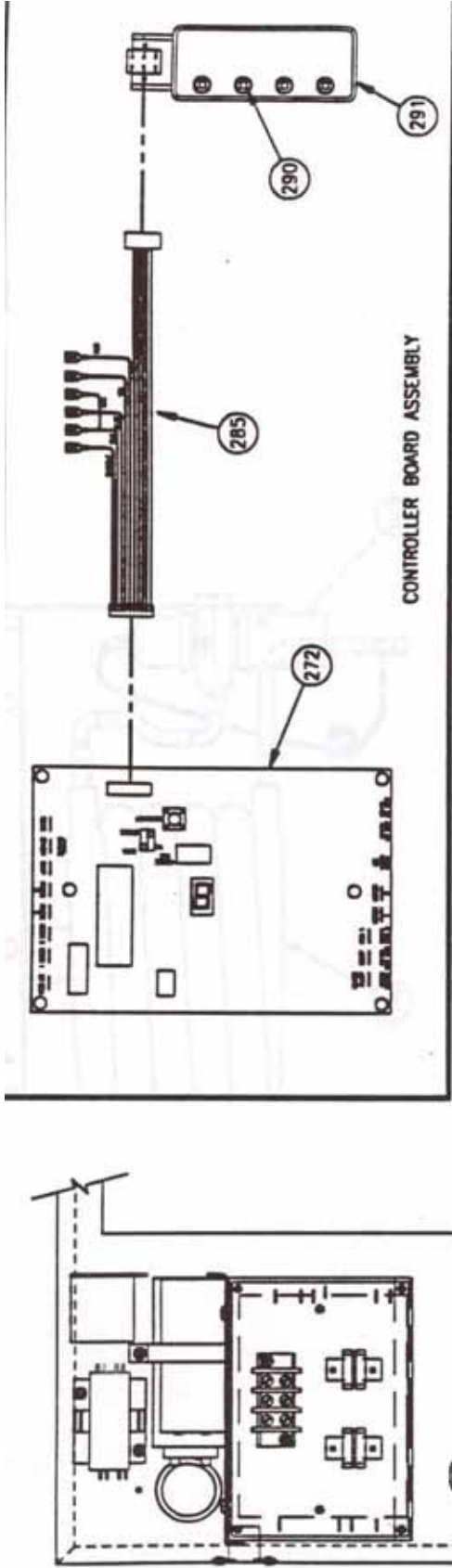

C61C

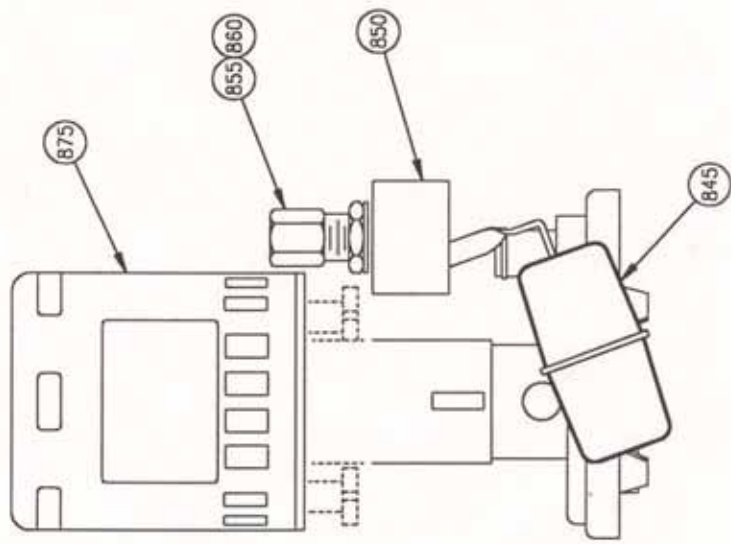

ICE-O-MATIC  
WATER PUMP/FLOAT

C61C

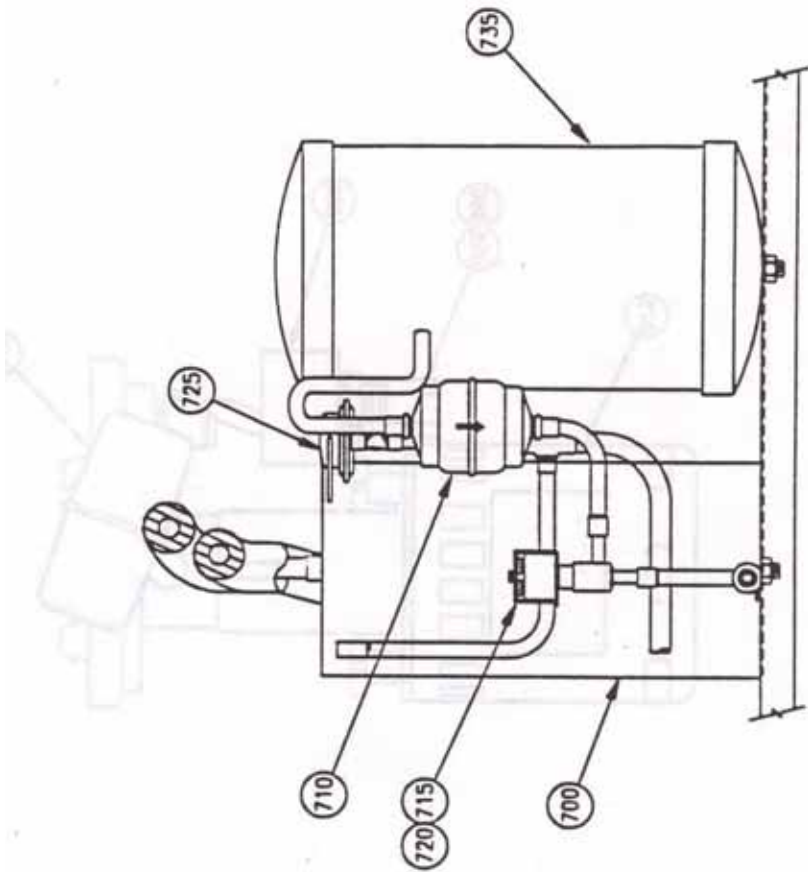

ICE-O-MATIC  
REMOTE RECEIVER  
ASSEMBLY

C61C

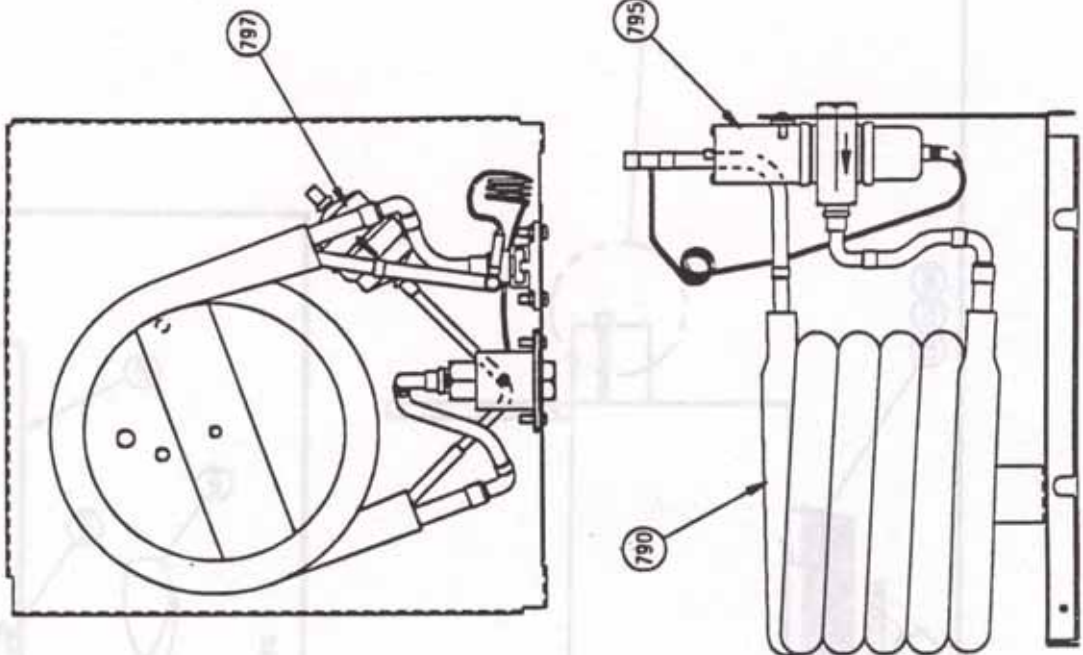

ICE-O-MATIC,  
WACO, TEXAS  
ASS'Y M857

C61C

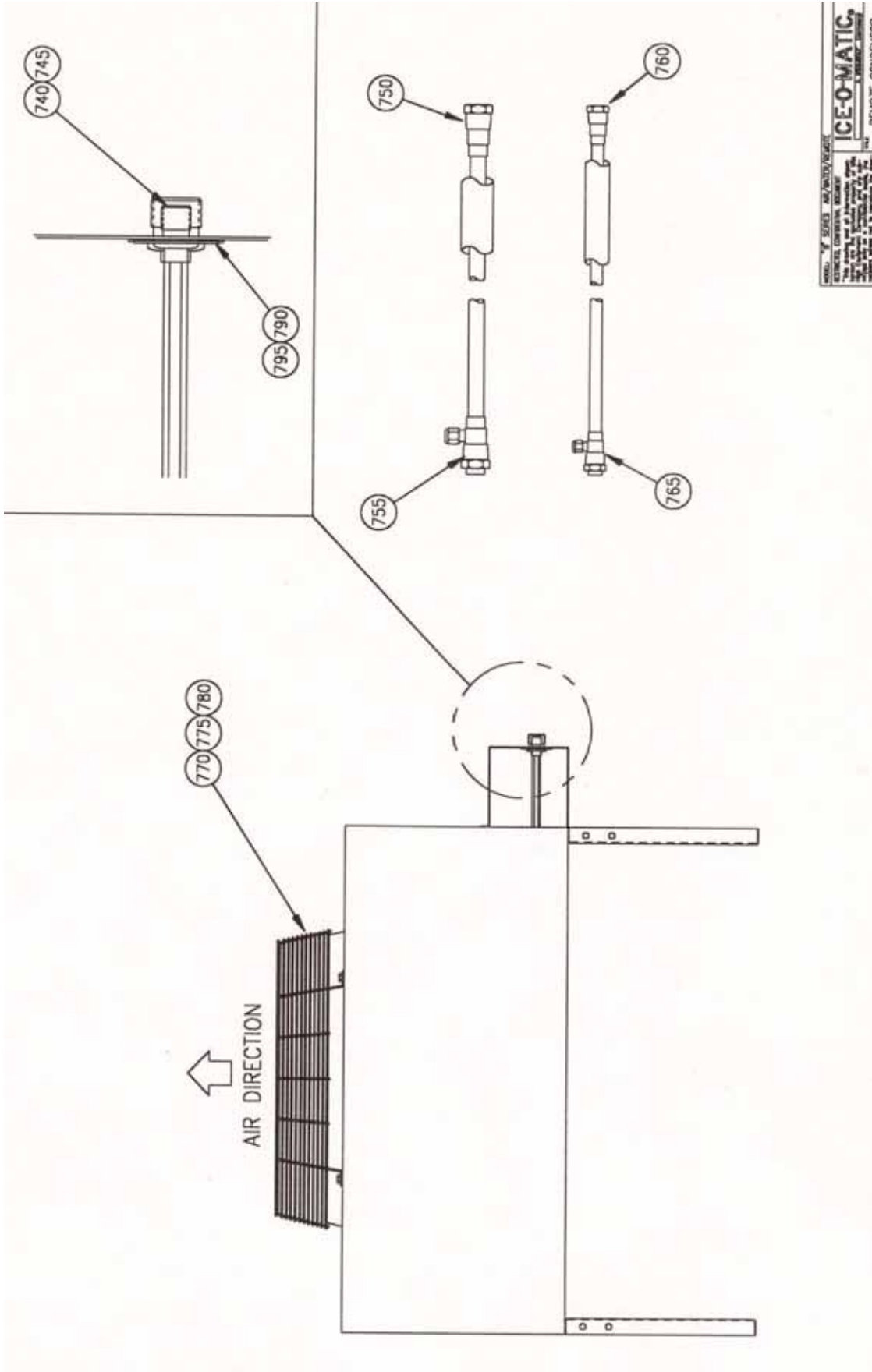

MODEL: Y SERIES AIR/WATER/HEAT  
REFRIG. CAPACITY: 1000 BTU  
1/2" COPPER TUBING  
1/2" COPPER TUBING  
1/2" COPPER TUBING  
ICE-MATIC  
REMOTE CONDENSER

C61C

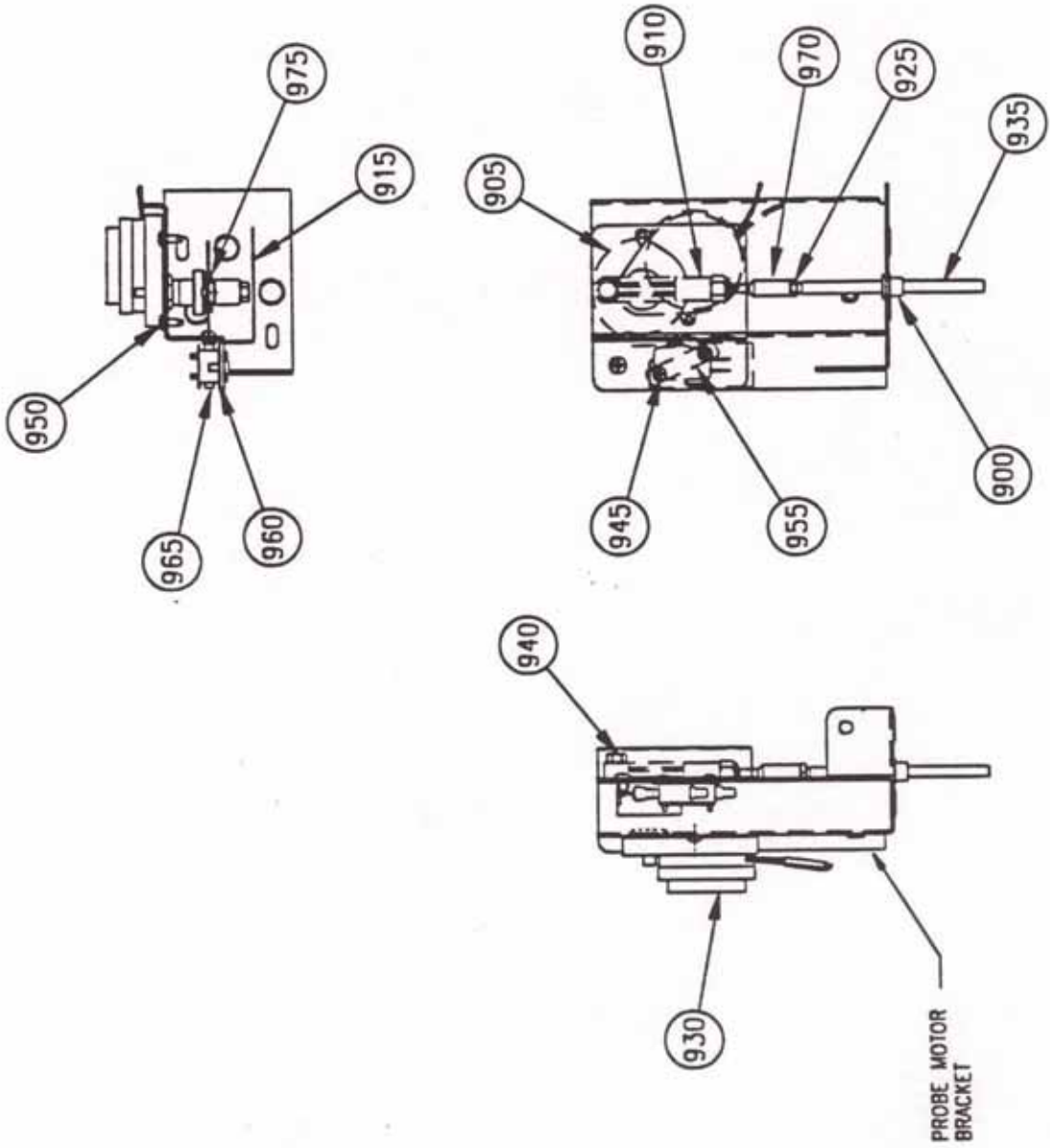

HARVEST PROBE ASSEMBLY

C81-121C

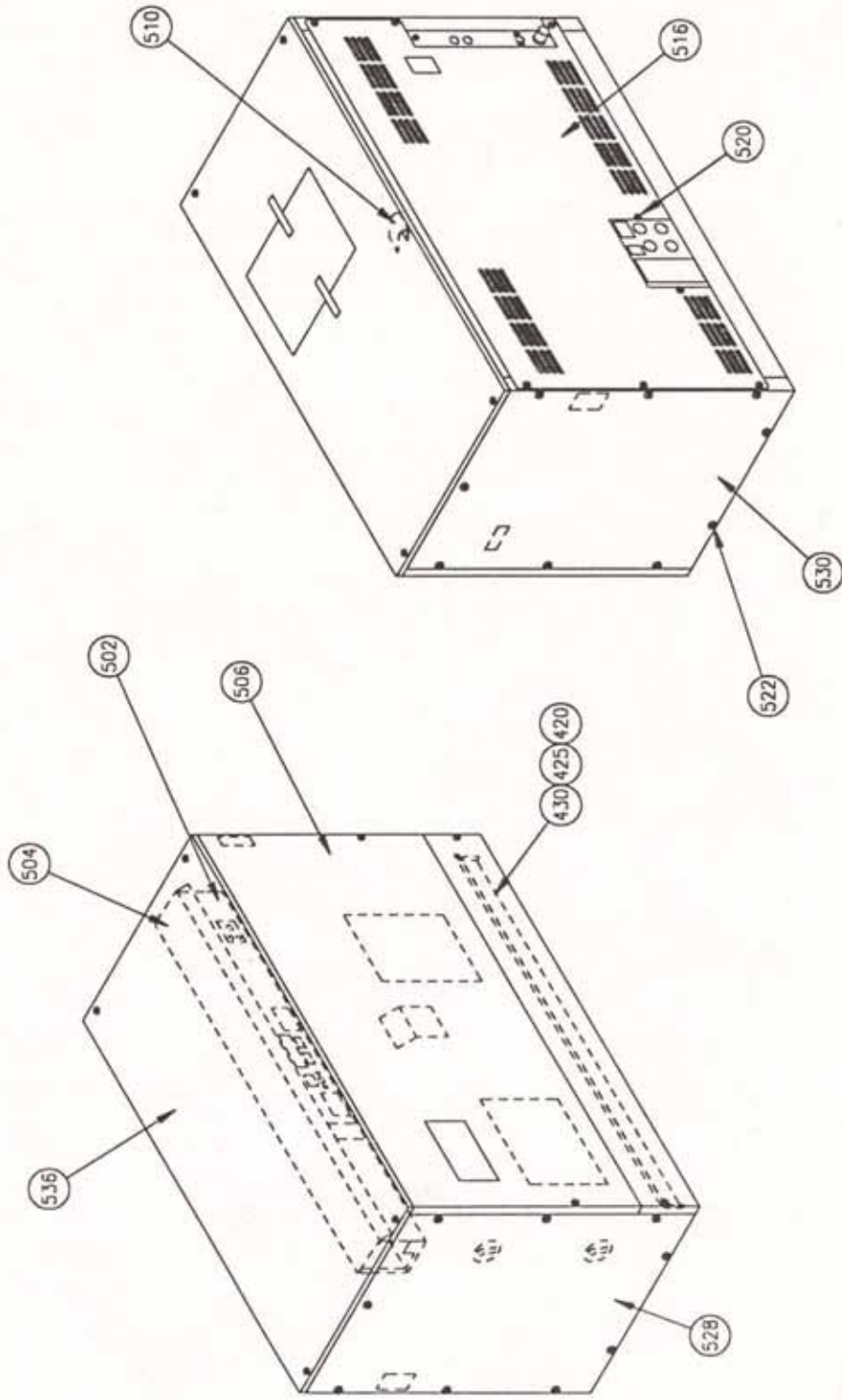

ICE-MATIC  
PANEL ASSEMBLY







C81-121C

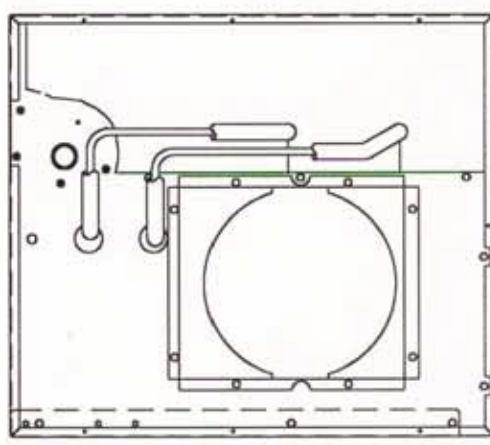
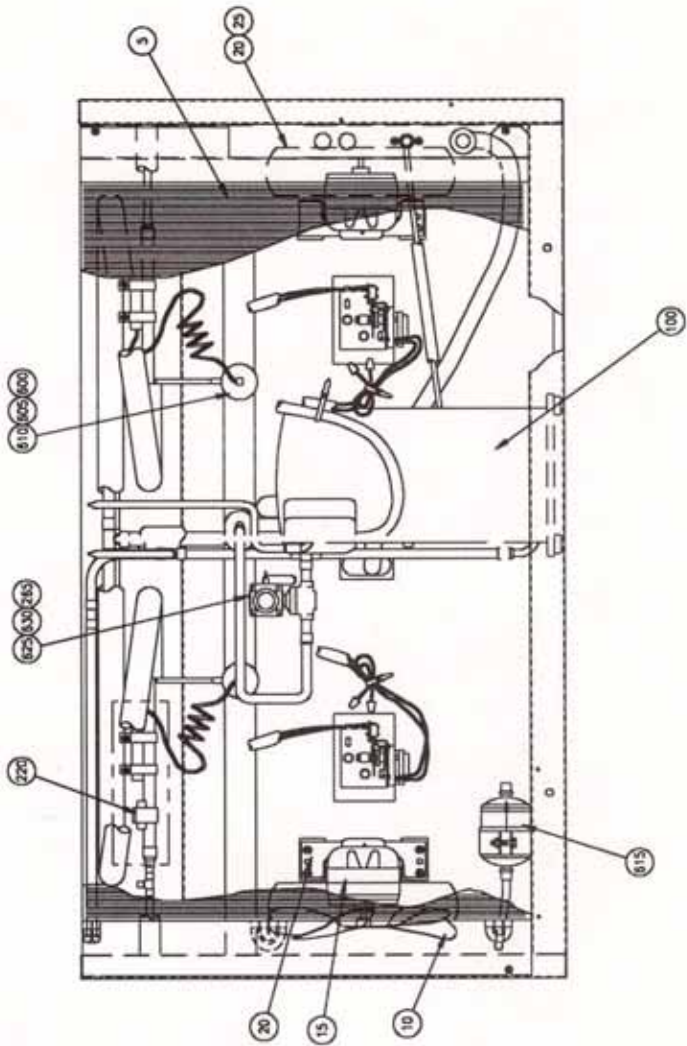

ICE-O-MATIC  
CHASSIS ASSEMBLY

C81-121C

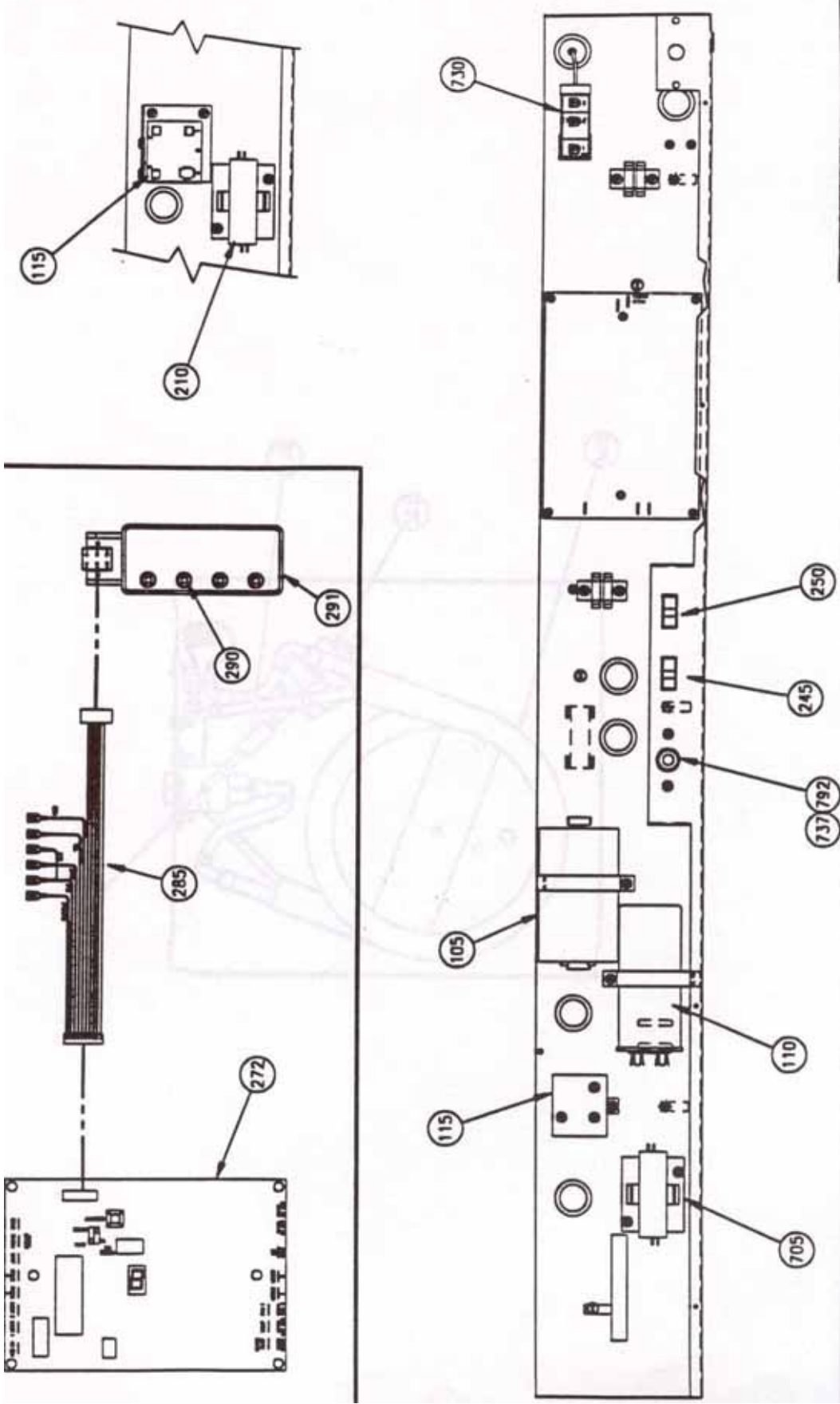

ICE-MATIC  
CONTROL BOX  
ASSEMBLY

C81C

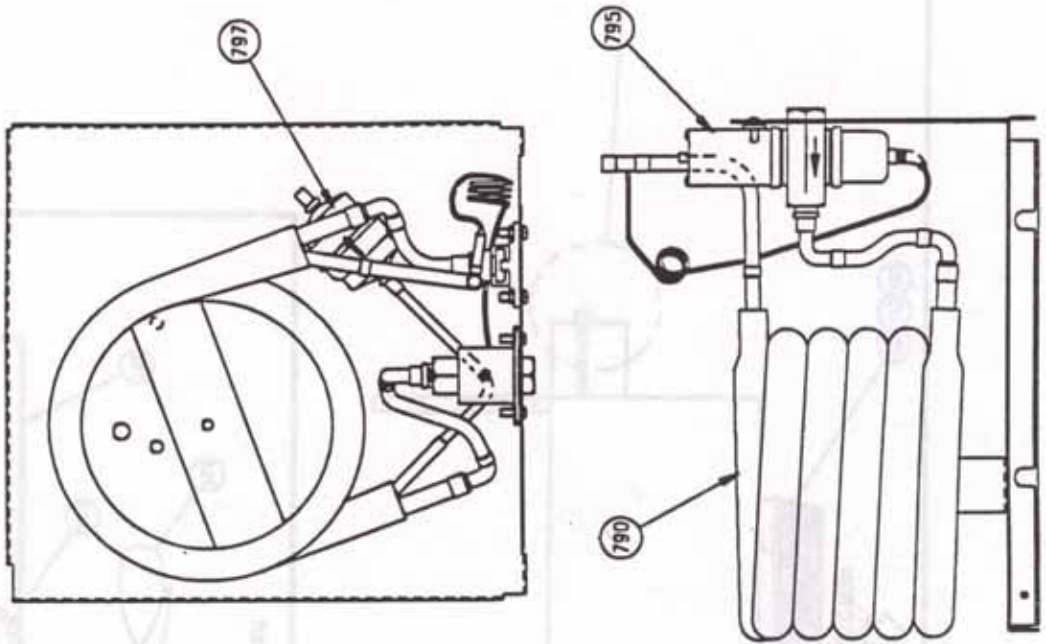

ICE-O-MATIC  
SECOND  
ASSEMBLY

C121C

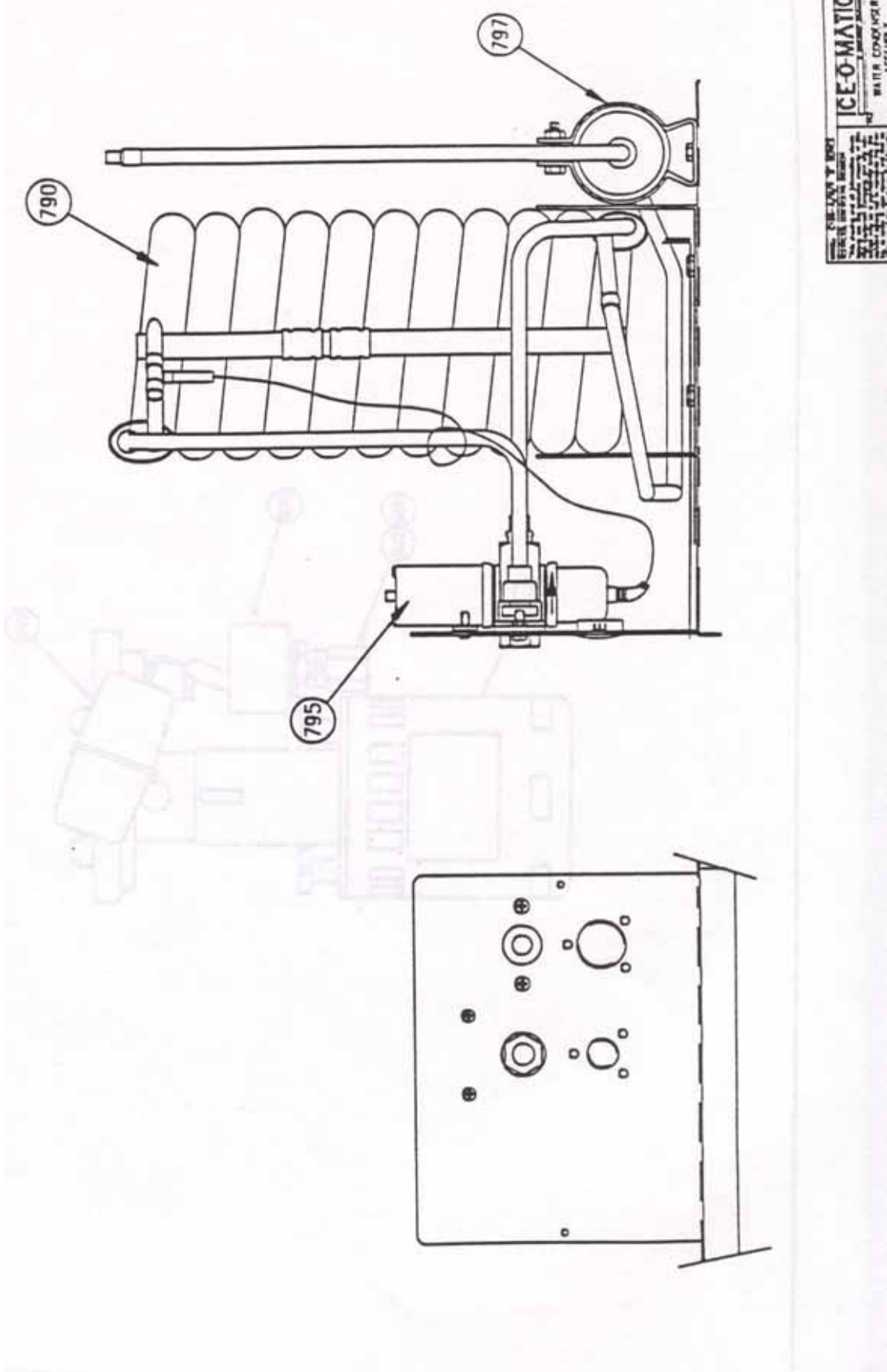

ICE-O-MATIC  
WATER CONDENSER

C81-121C

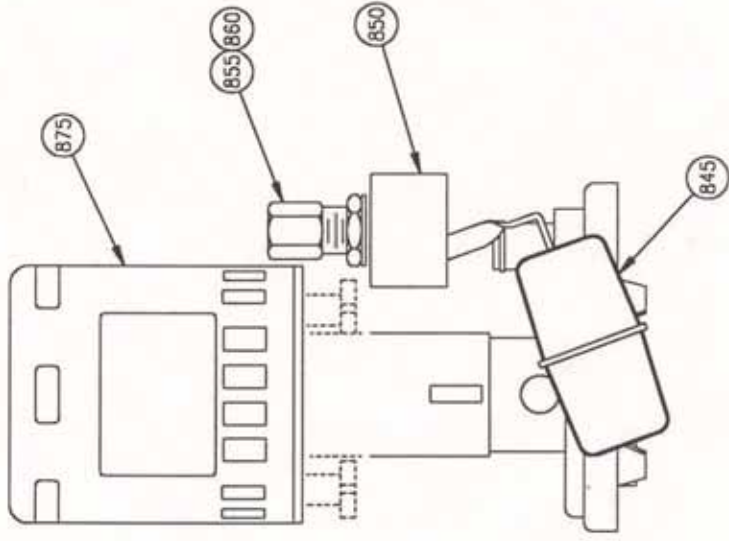

ICE-O-MATIC  
WATER PUMP/FLOAT

C81-121C

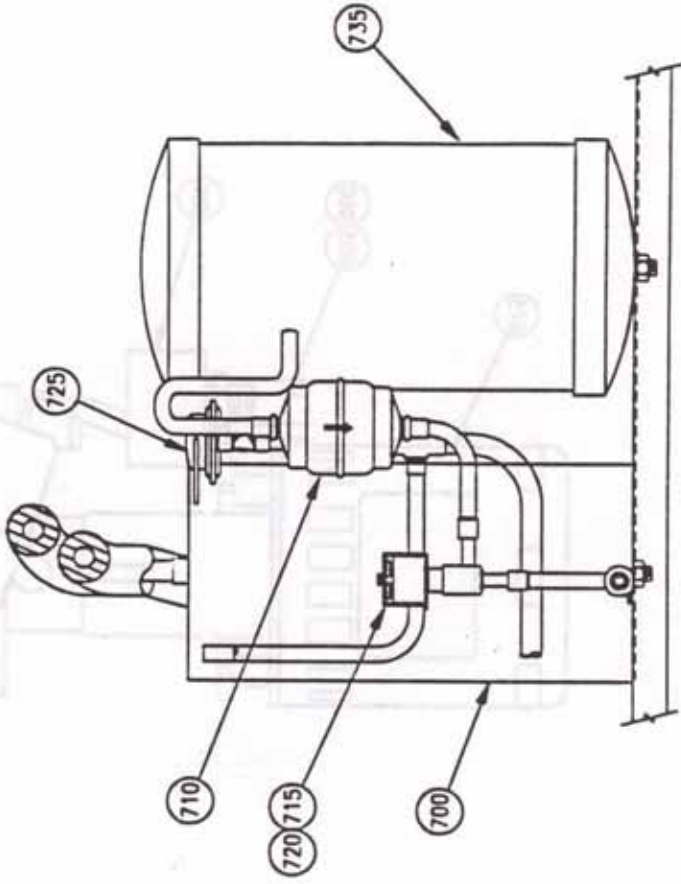

ICE-O-MATIC  
REMOTE RECEIVER  
ASSEMBLY

C81-121C

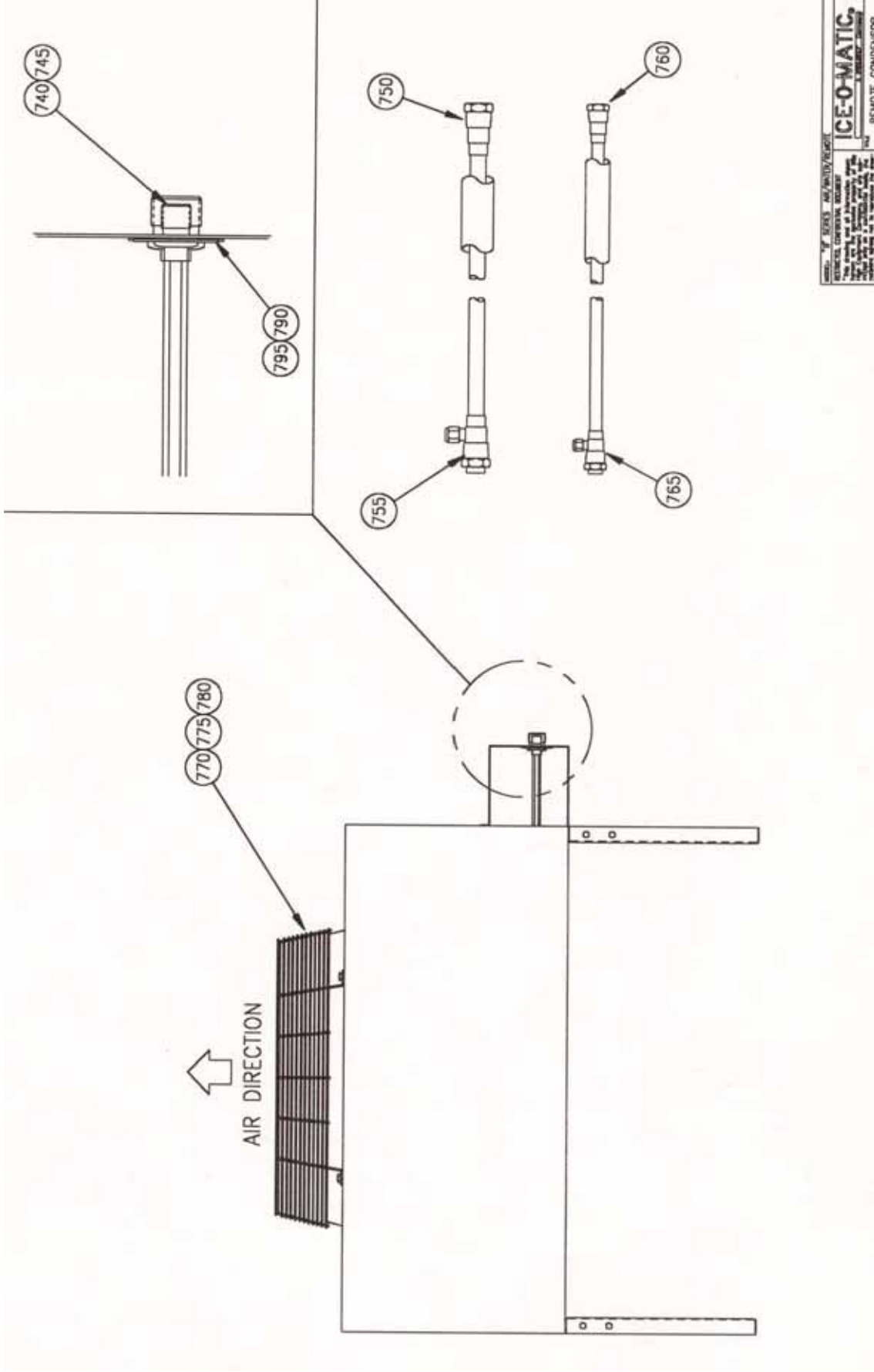



C81-121C

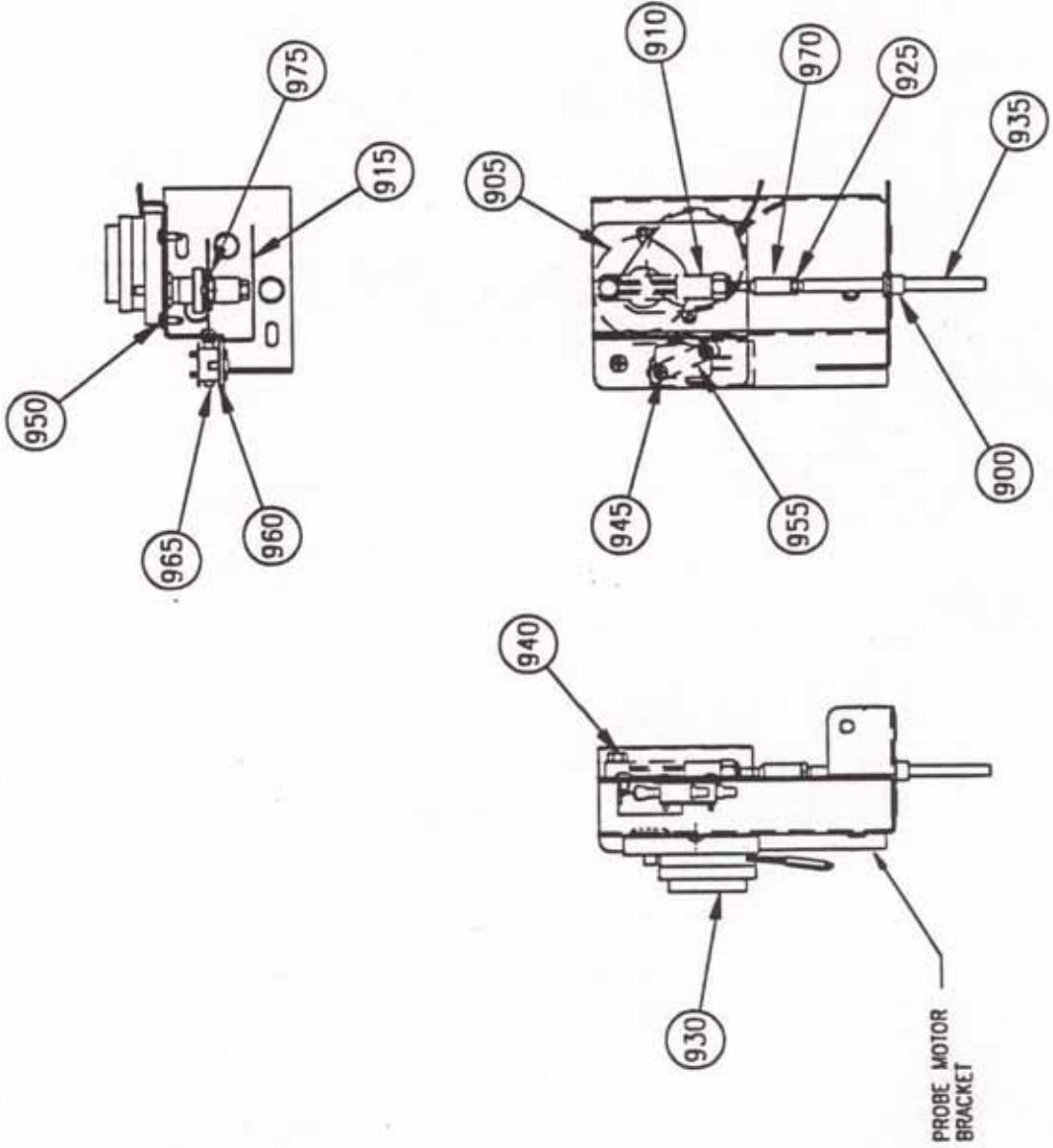

HARVEST PROBE ASSEMBLY



C146-186C

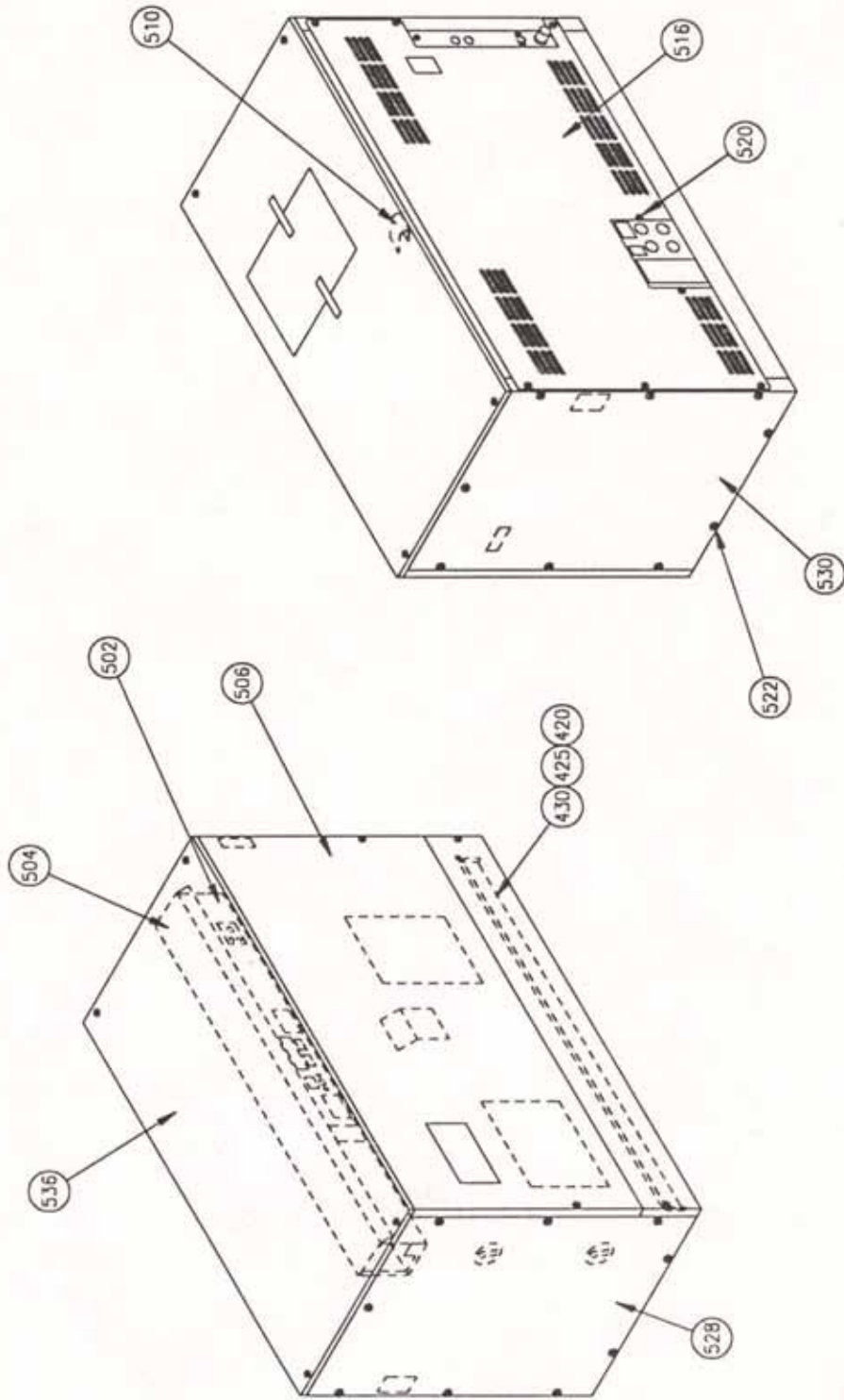

MODEL: ICE-O-MATIC SERIES  
RESPECTIVE COMPANY'S REGISTRATION  
TRADE MARKS ARE USED BY THE COMPANY  
FOR IDENTIFICATION PURPOSES ONLY  
ICE-O-MATIC IS A TRADE MARK OF THE COMPANY  
REGISTERED IN THE U.S. PATENT OFFICE  
ICE-O-MATIC PANEL ASSEMBLY  
PART NO. 146-186C

C146-186C

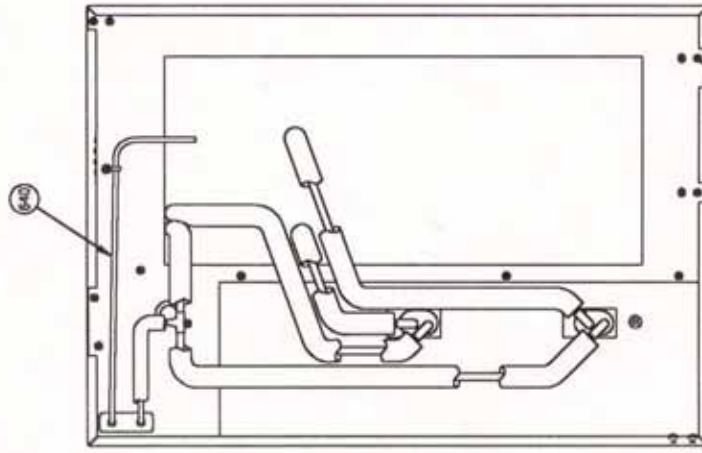
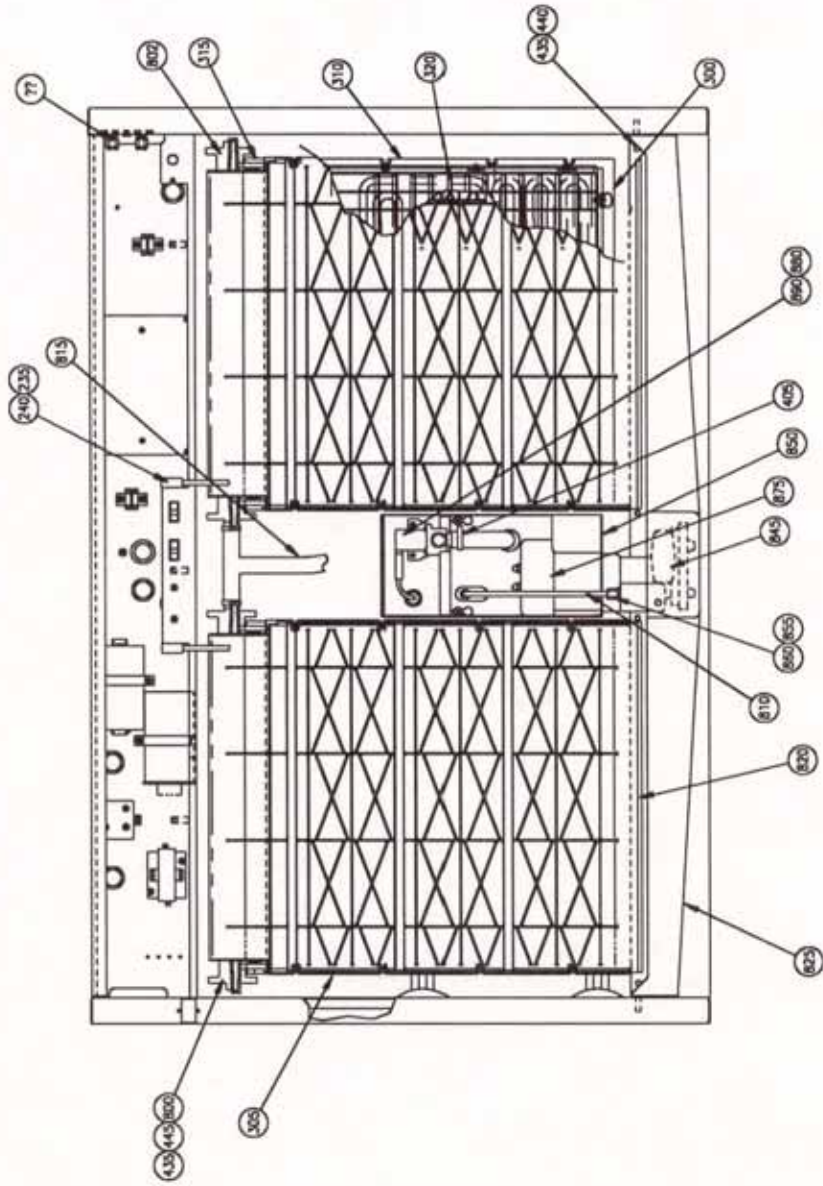

MODEL C146-186C PART OF SERIES  
REFRIGERATION ASSEMBLY  
ICE-O-MATIC  
THE CHASSIS ASSURANCE

C146-186C

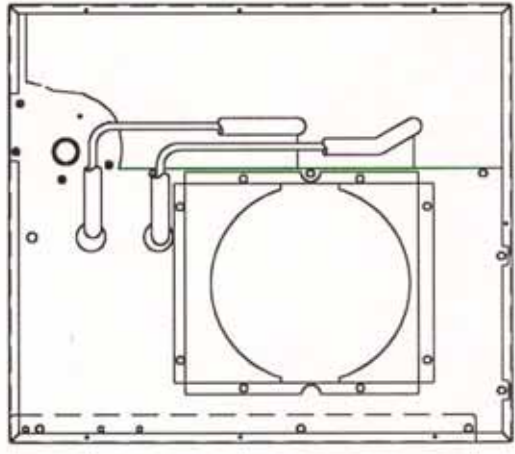
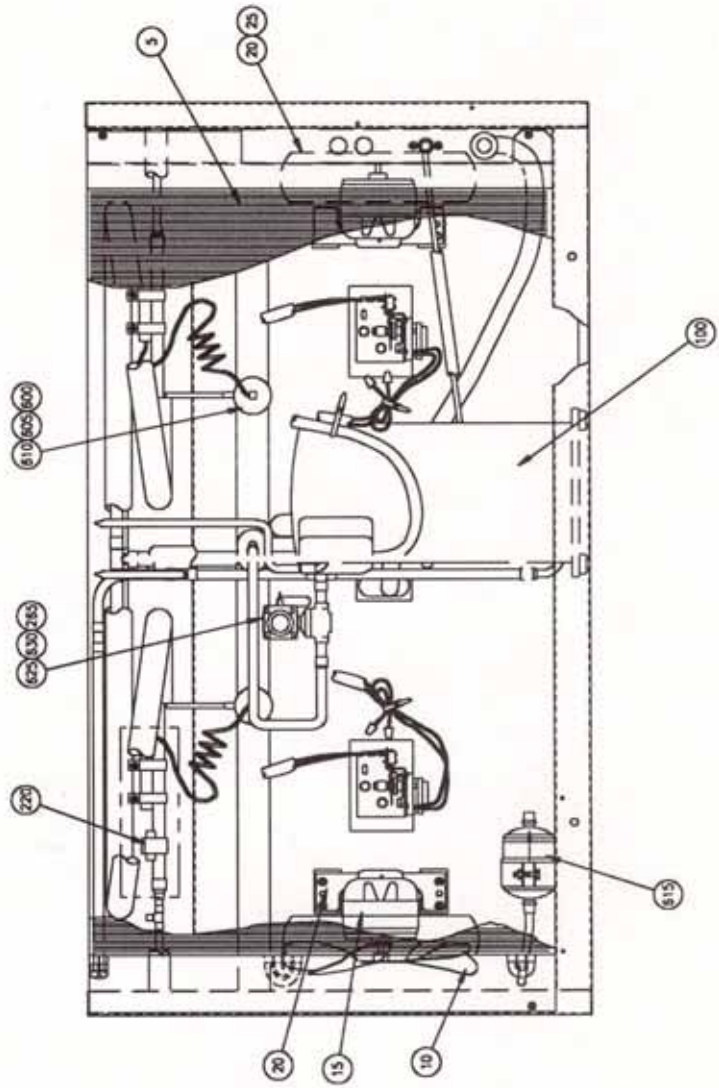

MODEL: ICE-O-MATIC CHASSIS ASSEMBLY  
PART NO.: C146-186C  
ICE-O-MATIC  
CHASSIS ASSEMBLY

C146-186C

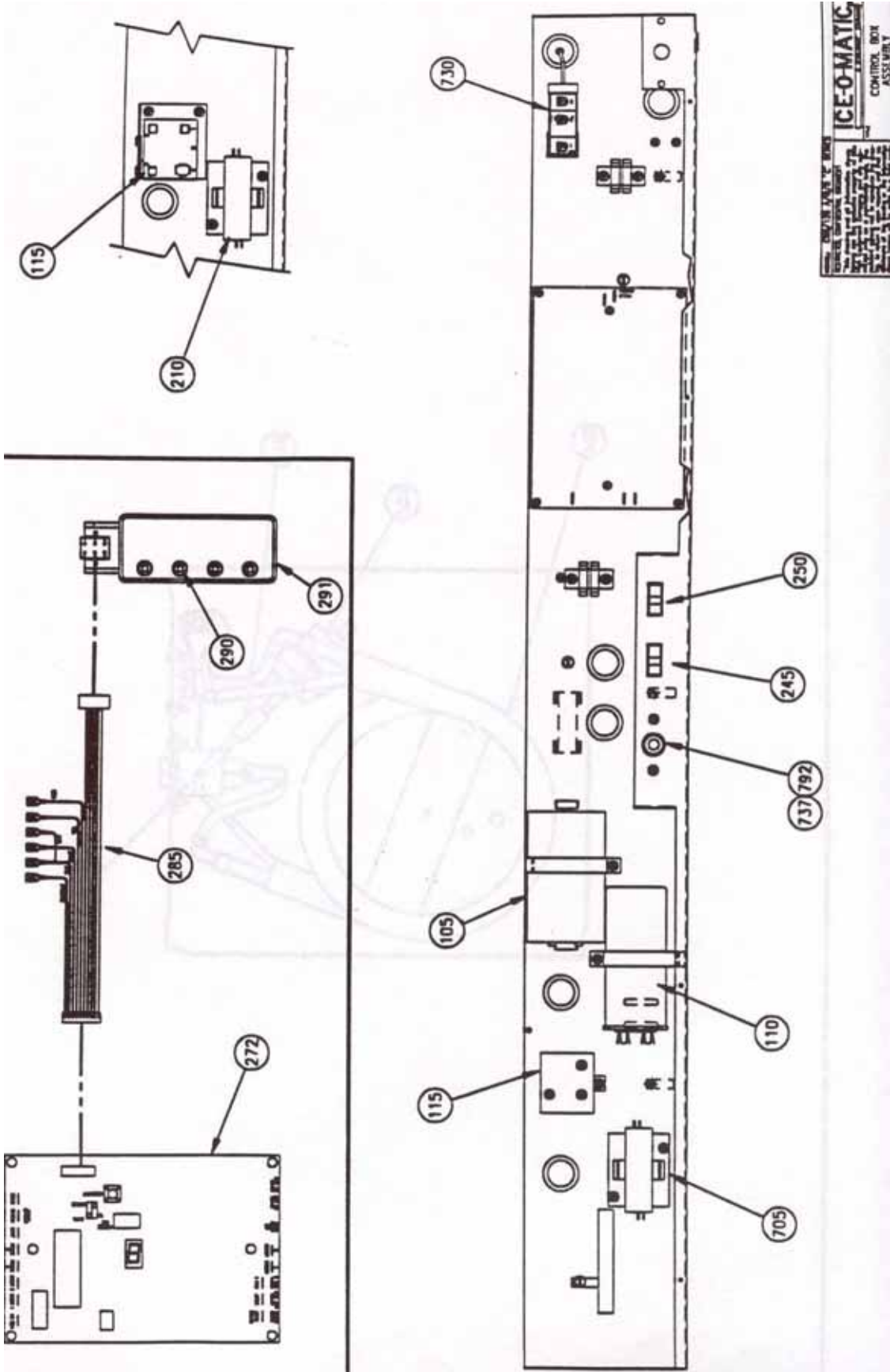

C146-186C

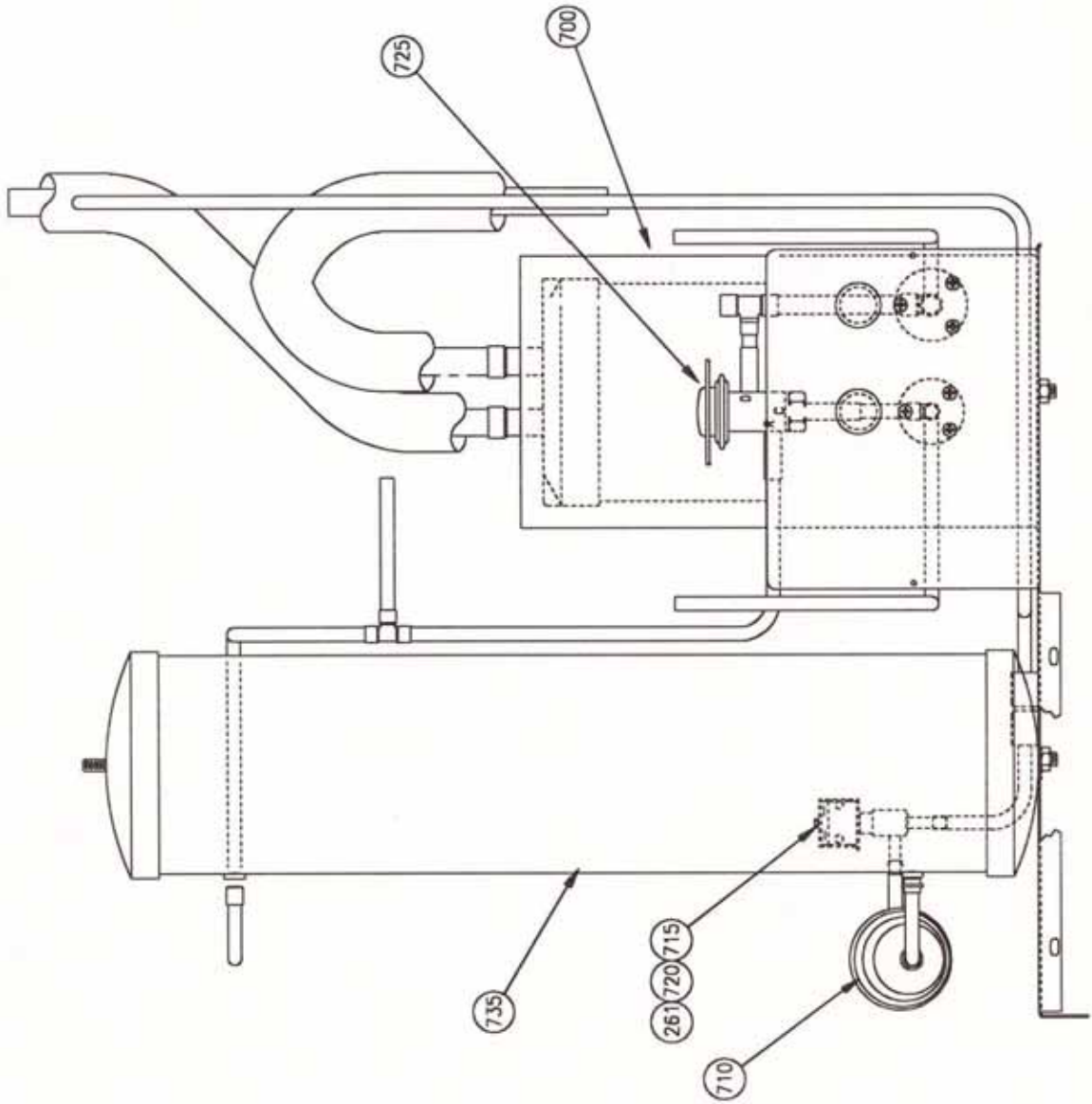

GENERAL CLIM-CLIM LINE OF SERIES  
REFRIGERATION SYSTEMS  
ICE-O-MATIC  
REMOTE CONDENSER  
ASSEMBLY  
PART 1, 207, 186C C146-186C-A



C146-186C

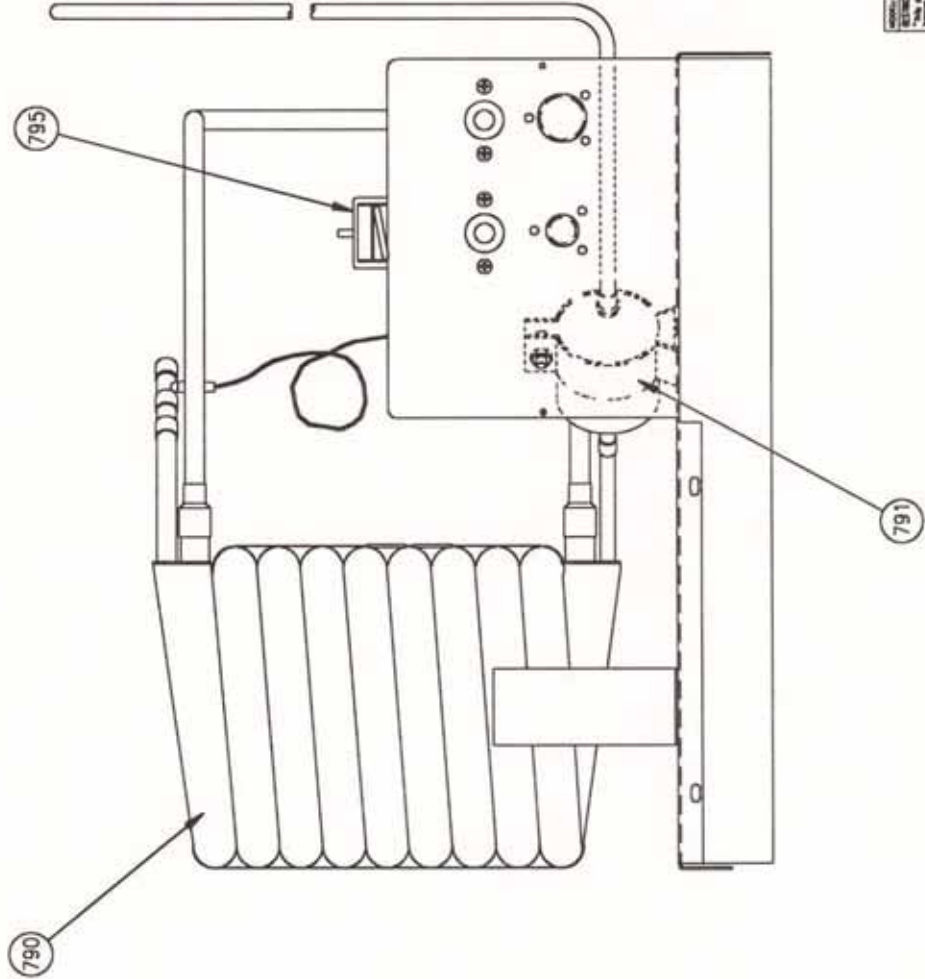

MODEL: CLM-CLM AND/VL OF SERIES  
GENERAL CONDENSER ASSEMBLY  
**ICE-O-MATIC**  
1947  
REMOTE CONDENSER  
ASSEMBLY  
REF. T. 202-1, 202-1A, 202-1B, 202-1C, 202-1D, 202-1E, 202-1F, 202-1G, 202-1H, 202-1I, 202-1J, 202-1K, 202-1L, 202-1M, 202-1N, 202-1O, 202-1P, 202-1Q, 202-1R, 202-1S, 202-1T, 202-1U, 202-1V, 202-1W, 202-1X, 202-1Y, 202-1Z, 202-1AA, 202-1AB, 202-1AC, 202-1AD, 202-1AE, 202-1AF, 202-1AG, 202-1AH, 202-1AI, 202-1AJ, 202-1AK, 202-1AL, 202-1AM, 202-1AN, 202-1AO, 202-1AP, 202-1AQ, 202-1AR, 202-1AS, 202-1AT, 202-1AU, 202-1AV, 202-1AW, 202-1AX, 202-1AY, 202-1AZ, 202-1BA, 202-1BB, 202-1BC, 202-1BD, 202-1BE, 202-1BF, 202-1BG, 202-1BH, 202-1BI, 202-1BJ, 202-1BK, 202-1BL, 202-1BM, 202-1BN, 202-1BO, 202-1BP, 202-1BQ, 202-1BR, 202-1BS, 202-1BT, 202-1BU, 202-1BV, 202-1BW, 202-1BX, 202-1BY, 202-1BZ, 202-1CA, 202-1CB, 202-1CC, 202-1CD, 202-1CE, 202-1CF, 202-1CG, 202-1CH, 202-1CI, 202-1CJ, 202-1CK, 202-1CL, 202-1CM, 202-1CN, 202-1CO, 202-1CP, 202-1CQ, 202-1CR, 202-1CS, 202-1CT, 202-1CU, 202-1CV, 202-1CW, 202-1CX, 202-1CY, 202-1CZ, 202-1DA, 202-1DB, 202-1DC, 202-1DD, 202-1DE, 202-1DF, 202-1DG, 202-1DH, 202-1DI, 202-1DJ, 202-1DK, 202-1DL, 202-1DM, 202-1DN, 202-1DO, 202-1DP, 202-1DQ, 202-1DR, 202-1DS, 202-1DT, 202-1DU, 202-1DV, 202-1DW, 202-1DX, 202-1DY, 202-1DZ, 202-1EA, 202-1EB, 202-1EC, 202-1ED, 202-1EE, 202-1EF, 202-1EG, 202-1EH, 202-1EI, 202-1EJ, 202-1EK, 202-1EL, 202-1EM, 202-1EN, 202-1EO, 202-1EP, 202-1EQ, 202-1ER, 202-1ES, 202-1ET, 202-1EU, 202-1EV, 202-1EW, 202-1EX, 202-1EY, 202-1EZ, 202-1FA, 202-1FB, 202-1FC, 202-1FD, 202-1FE, 202-1FF, 202-1FG, 202-1FH, 202-1FI, 202-1FJ, 202-1FK, 202-1FL, 202-1FM, 202-1FN, 202-1FO, 202-1FP, 202-1FQ, 202-1FR, 202-1FS, 202-1FT, 202-1FU, 202-1FV, 202-1FW, 202-1FX, 202-1FY, 202-1FZ, 202-1GA, 202-1GB, 202-1GC, 202-1GD, 202-1GE, 202-1GF, 202-1GG, 202-1GH, 202-1GI, 202-1GJ, 202-1GK, 202-1GL, 202-1GM, 202-1GN, 202-1GO, 202-1GP, 202-1GQ, 202-1GR, 202-1GS, 202-1GT, 202-1GU, 202-1GV, 202-1GW, 202-1GX, 202-1GY, 202-1GZ, 202-1HA, 202-1HB, 202-1HC, 202-1HD, 202-1HE, 202-1HF, 202-1HG, 202-1HH, 202-1HI, 202-1HJ, 202-1HK, 202-1HL, 202-1HM, 202-1HN, 202-1HO, 202-1HP, 202-1HQ, 202-1HR, 202-1HS, 202-1HT, 202-1HU, 202-1HV, 202-1HW, 202-1HX, 202-1HY, 202-1HZ, 202-1IA, 202-1IB, 202-1IC, 202-1ID, 202-1IE, 202-1IF, 202-1IG, 202-1IH, 202-1II, 202-1IJ, 202-1IK, 202-1IL, 202-1IM, 202-1IN, 202-1IO, 202-1IP, 202-1IQ, 202-1IR, 202-1IS, 202-1IT, 202-1IU, 202-1IV, 202-1IW, 202-1IX, 202-1IY, 202-1IZ, 202-1JA, 202-1JB, 202-1JC, 202-1JD, 202-1JE, 202-1JF, 202-1JG, 202-1JH, 202-1JI, 202-1JJ, 202-1JK, 202-1JL, 202-1JM, 202-1JN, 202-1JO, 202-1JP, 202-1JQ, 202-1JR, 202-1JS, 202-1JT, 202-1JU, 202-1JV, 202-1JW, 202-1JX, 202-1JY, 202-1JZ, 202-1KA, 202-1KB, 202-1KC, 202-1KD, 202-1KE, 202-1KF, 202-1KG, 202-1KH, 202-1KI, 202-1KJ, 202-1KK, 202-1KL, 202-1KM, 202-1KN, 202-1KO, 202-1KP, 202-1KQ, 202-1KR, 202-1KS, 202-1KT, 202-1KU, 202-1KV, 202-1KW, 202-1KX, 202-1KY, 202-1KZ, 202-1LA, 202-1LB, 202-1LC, 202-1LD, 202-1LE, 202-1LF, 202-1LG, 202-1LH, 202-1LI, 202-1LJ, 202-1LK, 202-1LL, 202-1LM, 202-1LN, 202-1LO, 202-1LP, 202-1LQ, 202-1LR, 202-1LS, 202-1LT, 202-1LU, 202-1LV, 202-1LW, 202-1LX, 202-1LY, 202-1LZ, 202-1MA, 202-1MB, 202-1MC, 202-1MD, 202-1ME, 202-1MF, 202-1MG, 202-1MH, 202-1MI, 202-1MJ, 202-1MK, 202-1ML, 202-1MM, 202-1MN, 202-1MO, 202-1MP, 202-1MQ, 202-1MR, 202-1MS, 202-1MT, 202-1MU, 202-1MV, 202-1MW, 202-1MX, 202-1MY, 202-1MZ, 202-1NA, 202-1NB, 202-1NC, 202-1ND, 202-1NE, 202-1NF, 202-1NG, 202-1NH, 202-1NI, 202-1NJ, 202-1NK, 202-1NL, 202-1NM, 202-1NN, 202-1NO, 202-1NP, 202-1NQ, 202-1NR, 202-1NS, 202-1NT, 202-1NU, 202-1NV, 202-1NW, 202-1NX, 202-1NY, 202-1NZ, 202-1OA, 202-1OB, 202-1OC, 202-1OD, 202-1OE, 202-1OF, 202-1OG, 202-1OH, 202-1OI, 202-1OJ, 202-1OK, 202-1OL, 202-1OM, 202-1ON, 202-1OO, 202-1OP, 202-1OQ, 202-1OR, 202-1OS, 202-1OT, 202-1OU, 202-1OV, 202-1OW, 202-1OX, 202-1OY, 202-1OZ, 202-1PA, 202-1PB, 202-1PC, 202-1PD, 202-1PE, 202-1PF, 202-1PG, 202-1PH, 202-1PI, 202-1PJ, 202-1PK, 202-1PL, 202-1PM, 202-1PN, 202-1PO, 202-1PP, 202-1PQ, 202-1PR, 202-1PS, 202-1PT, 202-1PU, 202-1PV, 202-1PW, 202-1PX, 202-1PY, 202-1PZ, 202-1QA, 202-1QB, 202-1QC, 202-1QD, 202-1QE, 202-1QF, 202-1QG, 202-1QH, 202-1QI, 202-1QJ, 202-1QK, 202-1QL, 202-1QM, 202-1QN, 202-1QO, 202-1QP, 202-1QQ, 202-1QR, 202-1QS, 202-1QT, 202-1QU, 202-1QV, 202-1QW, 202-1QX, 202-1QY, 202-1QZ, 202-1RA, 202-1RB, 202-1RC, 202-1RD, 202-1RE, 202-1RF, 202-1RG, 202-1RH, 202-1RI, 202-1RJ, 202-1RK, 202-1RL, 202-1RM, 202-1RN, 202-1RO, 202-1RP, 202-1RQ, 202-1RR, 202-1RS, 202-1RT, 202-1RU, 202-1RV, 202-1RW, 202-1RX, 202-1RY, 202-1RZ, 202-1SA, 202-1SB, 202-1SC, 202-1SD, 202-1SE, 202-1SF, 202-1SG, 202-1SH, 202-1SI, 202-1SJ, 202-1SK, 202-1SL, 202-1SM, 202-1SN, 202-1SO, 202-1SP, 202-1SQ, 202-1SR, 202-1SS, 202-1ST, 202-1SU, 202-1SV, 202-1SW, 202-1SX, 202-1SY, 202-1SZ, 202-1TA, 202-1TB, 202-1TC, 202-1TD, 202-1TE, 202-1TF, 202-1TG, 202-1TH, 202-1TI, 202-1TJ, 202-1TK, 202-1TL, 202-1TM, 202-1TN, 202-1TO, 202-1TP, 202-1TQ, 202-1TR, 202-1TS, 202-1TT, 202-1TU, 202-1TV, 202-1TW, 202-1TX, 202-1TY, 202-1TZ, 202-1UA, 202-1UB, 202-1UC, 202-1UD, 202-1UE, 202-1UF, 202-1UG, 202-1UH, 202-1UI, 202-1UJ, 202-1UK, 202-1UL, 202-1UM, 202-1UN, 202-1UO, 202-1UP, 202-1UQ, 202-1UR, 202-1US, 202-1UT, 202-1UU, 202-1UV, 202-1UW, 202-1UX, 202-1UY, 202-1UZ, 202-1VA, 202-1VB, 202-1VC, 202-1VD, 202-1VE, 202-1VF, 202-1VG, 202-1VH, 202-1VI, 202-1VJ, 202-1VK, 202-1VL, 202-1VM, 202-1VN, 202-1VO, 202-1VP, 202-1VQ, 202-1VR, 202-1VS, 202-1VT, 202-1VU, 202-1VV, 202-1VW, 202-1VX, 202-1VY, 202-1VZ, 202-1WA, 202-1WB, 202-1WC, 202-1WD, 202-1WE, 202-1WF, 202-1WG, 202-1WH, 202-1WI, 202-1WJ, 202-1WK, 202-1WL, 202-1WM, 202-1WN, 202-1WO, 202-1WP, 202-1WQ, 202-1WR, 202-1WS, 202-1WT, 202-1WU, 202-1WV, 202-1WW, 202-1WX, 202-1WY, 202-1WZ, 202-1XA, 202-1XB, 202-1XC, 202-1XD, 202-1XE, 202-1XF, 202-1XG, 202-1XH, 202-1XI, 202-1XJ, 202-1XK, 202-1XL, 202-1XM, 202-1XN, 202-1XO, 202-1XP, 202-1XQ, 202-1XR, 202-1XS, 202-1XT, 202-1XU, 202-1XV, 202-1XW, 202-1XX, 202-1XY, 202-1XZ, 202-1YA, 202-1YB, 202-1YC, 202-1YD, 202-1YE, 202-1YF, 202-1YG, 202-1YH, 202-1YI, 202-1YJ, 202-1YK, 202-1YL, 202-1YM, 202-1YN, 202-1YO, 202-1YP, 202-1YQ, 202-1YR, 202-1YS, 202-1YT, 202-1YU, 202-1YV, 202-1YW, 202-1YX, 202-1YY, 202-1YZ, 202-1ZA, 202-1ZB, 202-1ZC, 202-1ZD, 202-1ZE, 202-1ZF, 202-1ZG, 202-1ZH, 202-1ZI, 202-1ZJ, 202-1ZK, 202-1ZL, 202-1ZM, 202-1ZN, 202-1ZO, 202-1ZP, 202-1ZQ, 202-1ZR, 202-1ZS, 202-1ZT, 202-1ZU, 202-1ZV, 202-1ZW, 202-1ZX, 202-1ZY, 202-1ZZ

C146-186C

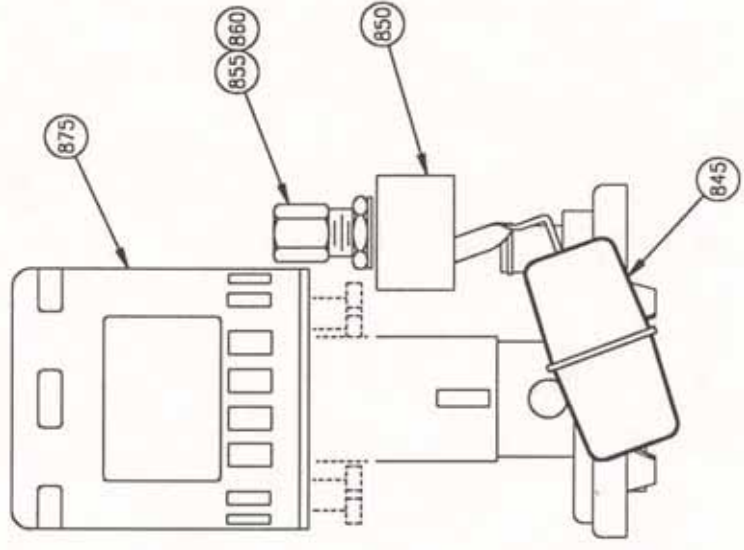

ICE-MATIC  
WATER PUMP/FLOAT

C146-186C

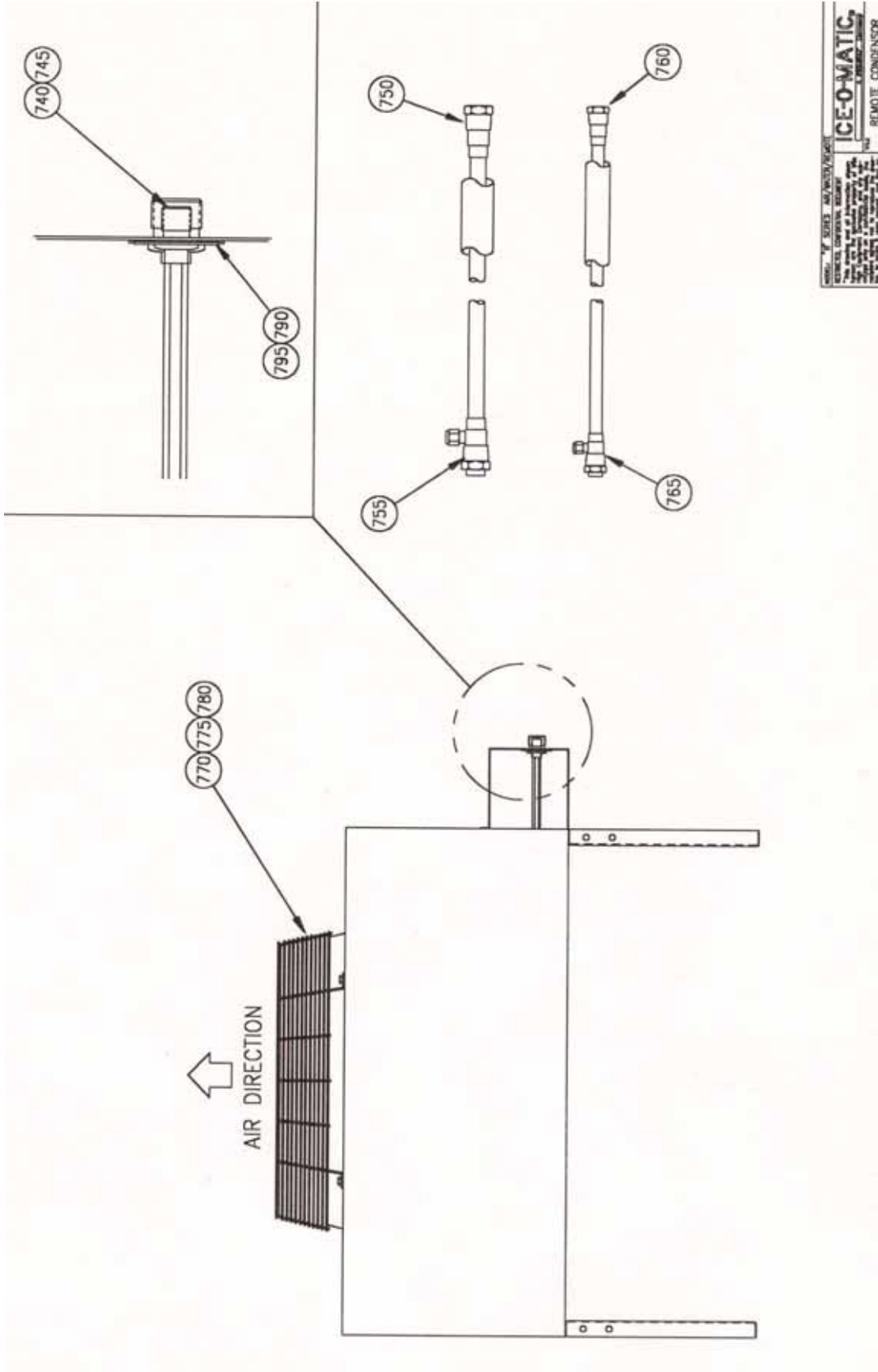



C146-186C

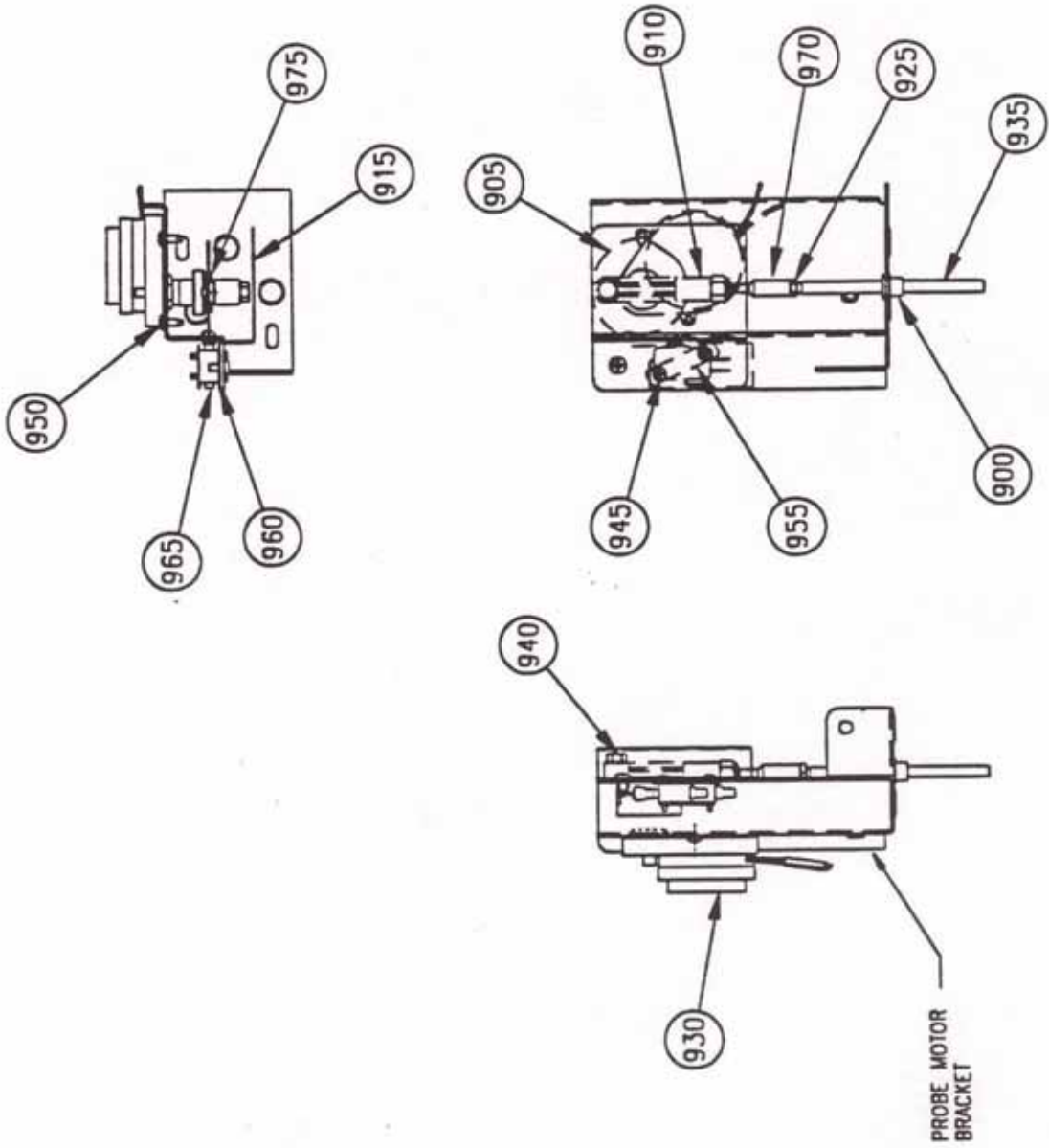

HARVEST PROBE ASSEMBLY